

MVAA-220 series

PILOT VALVE



Specification

Model	3A1	3A2	4A1	4A2	4A2C.PR
Bore No.	8A				
Port size	Rc1/4				
No. of port	3		5		
Medium	Air				
Operating pressure range	0~0.8 MPa				
Proof pressure	1 MPa				
Effective orifice	18 mm ²				
Pilot pressure range	(0.3×P*+0.1)~0.8 MPa				
Ambient temperature	-5~+60°C (No freezing)				
Weight	122 g	134 g	106 g	134 g	179 g

* P: Operating pressure.

Order example

MVAA – 220M – 4A2C – NC – G

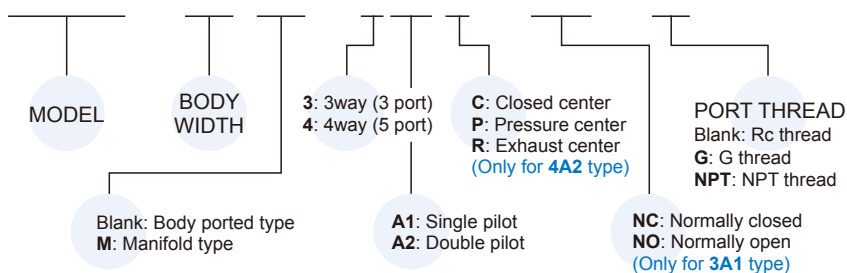

Flow features

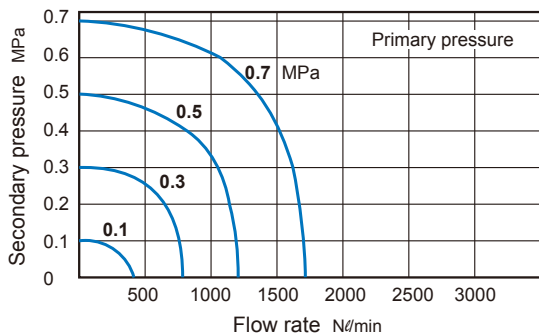

MVAA-220-4A1

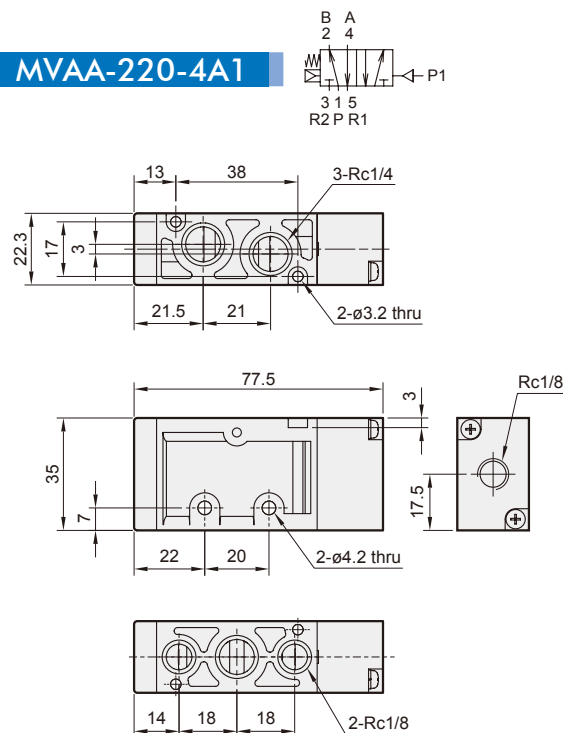

MVAA-220 Dimensions

PILOT VALVE



MVAA-220-4A2

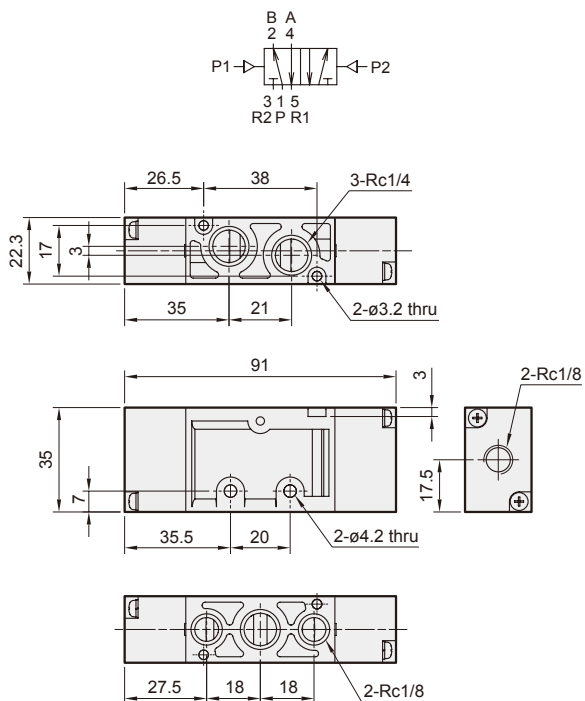

MVAA-220-4A2C.P.R

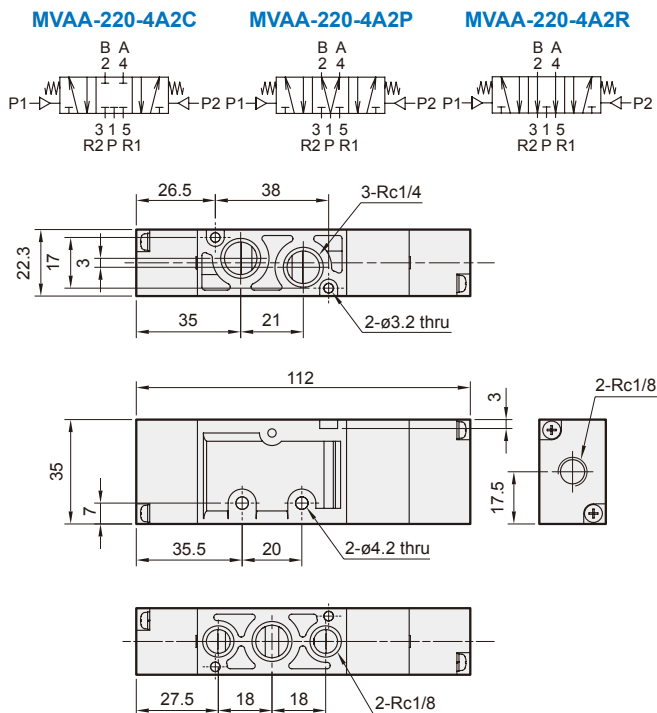

MVAA-220-3A1-NC/NO

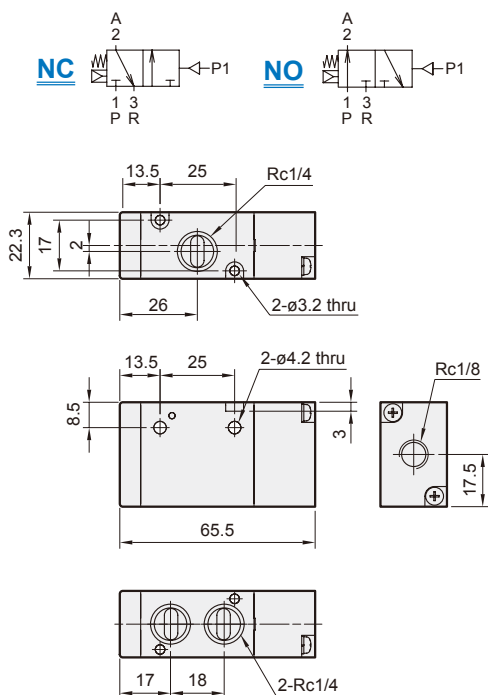

MVAA-220-3A2

