

Servo drive CMMT-AS

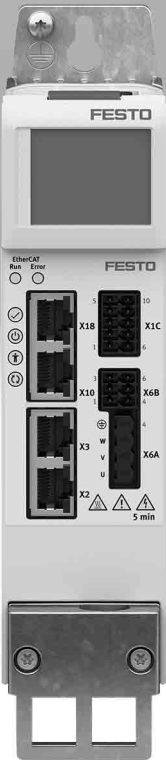

Servo drive CMMT-AS

Key features



At a glance

- Universal servo drive for PM synchronous servo motors up to 2500 W
- Supports the motor series EMMT-AS, EMME-AS and EMMS-AS as well as third-party motors
- Integrated single-phase/three-phase mains connection 230/400 V AC, mains filter and braking resistor, connection option for external braking resistor
- Precise force, speed and position control
- Movements from point-to-point to interpolated motion
- Comprehensively integrated protective functions for the servo drive, motor and axis with automatic motor shut-down/quick stop
- Bus protocols



- Prepared device description files and function elements for integration in PLC systems

- Configuration:
 - Automatically with the "Festo Automation Suite" as well as auto-tuning
 - Directly via fieldbus and PLC
 - Data backup concept via PLC or control unit CDSB
- Supports digital absolute encoders (EnDat, Hiperface, Nikon-A) in the motor as well as incremental (A/B, Sin/Cos) displacement encoders on the axis
- Integrated safety functions:
 - Safe torque off (STO) up to SIL3/Cat. 4 PL e
 - Safe stop 1 (SS1) when using a suitable external safety relay unit and suitable circuitry for the servo drive
 - Safe brake control (SBC) up to SIL3/Cat. 3 PL e
 - Diagnostic outputs STA and SBA for feedback on the active safety function

The technology in detail

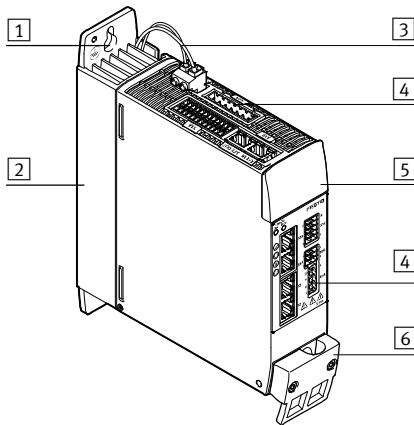

- 1 Elongated hole for mounting the servo drive on the control cabinet back wall
- 2 Cooling element for dissipating heat. The internal braking resistor is housed in the cooling element.
- 3 Connection for braking resistor
- 4 Connections
- 5 Blanking plate (optionally with plug-on control unit CDSB → page 13)
- 6 Shield clamp and strain relief

Library for EPLAN

→ www.festo.de/eplan



EPLAN macros for fast and reliable planning of electrical projects in combination with servo drives, motors and

cables. This enables a high level of planning reliability, standardisation of

documentation, without the need to create symbols, graphics and master data.

PositioningDrives

Planning of electromechanical drives

No.	Axis	Size	Guide	Motor	Motor Size	Gear	Axis	Motor	Guide	Travel time
1	Ball screw (ELGC)	45	Ball bearing	Servo AC (EA)	40-S	---	33 %	98 %	23 %	2,215
2	Ball screw (ELGC)	45	Ball bearing	Servo AC (EA)	40-M	---	39 %	74 %	27 %	1,807
3	Ball screw (ELGC)	45	Ball bearing	Servo AC (EA)	60-S	---	40 %	59 %	27 %	1,804
4	Ball screw (ELGC)	45	Ball bearing	Servo AC (EA)	60-M	---	40 %	25 %	27 %	1,803
5	Ball screw (ELGC)	60	Ball bearing	Servo AC (EA)	60-S	---	32 %	85 %	7 %	1,380
6	Ball screw (ELGC)	60	Ball bearing	Servo AC (EA)	60-M	---	32 %	29 %	7 %	1,379

Create the optimum drive package quickly and reliably. PositioningDrives calculates suitable combinations of electric axis, electric motor and servo drive from just a few application details. You sort the results according to your specifications and obtain all the relevant data including the bill of materials and documentation for the selected combination. This avoids design errors and results in significantly improved energy efficiency for the system.

Servo drive CMMT-AS

Key features

Festo Automation Suite

Parameterisation and programming software for electronic devices from Festo

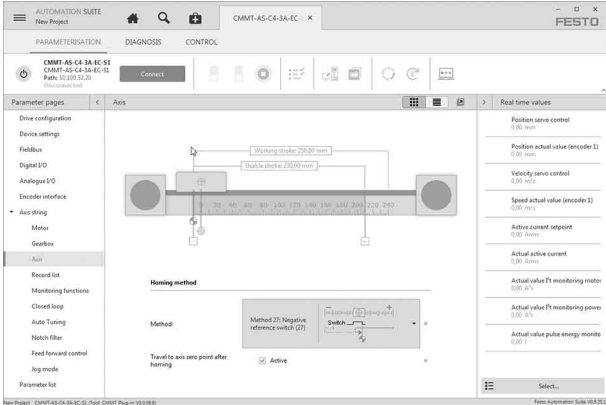

- Parameterisation, programming and commissioning in a clear and user-friendly interface
- Optimum support for complex processes thanks to guided wizards (e.g. for commissioning, drive configuration, etc.)
- Fast access to required documents and additional information
- Easy integration of electric drives in the controller programming

System overview

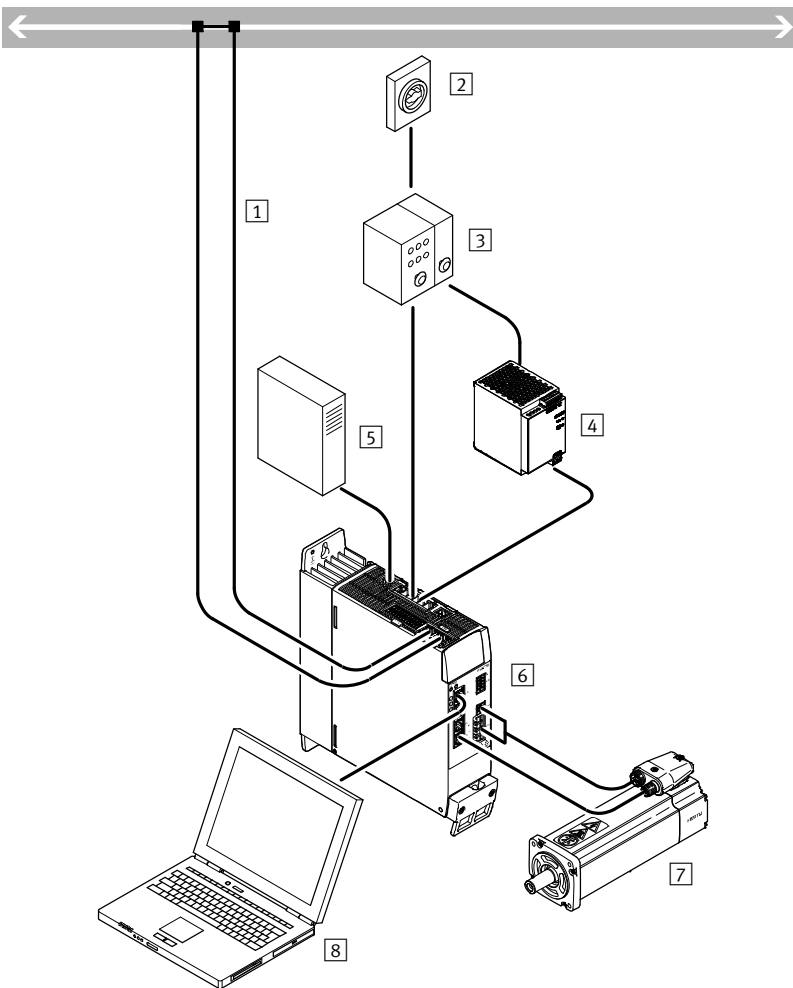

- 1 Bus/network
- 2 Main switch
- 3 Circuit breaker/fuses
- 4 Power supply unit for logic voltage supply 24 V DC (PELV)
- 5 External braking resistor (optional)
- 6 Servo drive CMMT-AS
- 7 Servo motor
- 8 PC with Ethernet connection for parameterisation

Servo drive CMMT-AS

Type codes

CMMT – AS – C4 – 3A – – EC – S1

Type	
CMMT	Servo drive
Motor technology	
AS	AC synchronous
Nominal current	
C2	2 A
C3	3 A
C4	4 A
C5	5 A
Input voltage	
3A	230 V AC
11A	400 V AC
Number of phases	
–	Single-phase
P3	Three-phase
Bus protocol/activation	
EC	EtherCAT
PN	PROFINET RT/IRT
Safety function	
S1	Standard safety

Servo drive CMMT-AS

Technical data

Bus protocols



General technical data					
CMMT-AS-	C2-3A-...	C4-3A-...	C2-11A-...	C3-11A-...	C5-11A-...
Type of mounting	Mounting plate, screwed in				
Indicator	Green/yellow/red LED or control unit CDSB with plain text message				
Controller operating mode	<ul style="list-style-type: none"> • Cascade controller • P position controller • PI speed controller • PI current regulator for F or M • Profile operation with record and direct mode • Interpolated mode via fieldbus • Homing/setup mode/auto-tuning 				
Operating mode	<ul style="list-style-type: none"> • Field-oriented control, position resolution 24-bit/U • Sampling rate 16 kHz • PWM with 8 or 16 kHz, vector modulation with third harmonic • Real-time data acquisition: <ul style="list-style-type: none"> – 2x input position capture – 2x output position trigger – 2x position encoder input – 1x SYNC interface for encoder emulation or encoder input 				
Mounting position	Vertical				
Product weight [g]	1300	1400	2100	2100	2200

Bus protocol		
Interface	EtherCAT	PROFINET RT/IRT
Function	Bus connection incoming/outgoing	
Process interfacing	Interpolated mode CSP	AC1: Adjustable-Speed Drives
	Interpolated mode CSV	AC3: Drive with Positioning Function
	Interpolated mode CST	AC4: Synchronous Servo Application
	Point-to-point mode PP	–
	Point-to-point mode PV	–
	Point-to-point mode PT	–
	Homing mode HM	–
Record table with 128 entries	–	
Communication profile	CiA402	PROFIdrive
	CoE (CANopen over EtherCAT)	PROFIenergy
	EoE (Ethernet over EtherCAT)	–
Max. fieldbus transmission rate [Mbit/s]	100	
Connection type	2x socket	
Connection technology	RJ45	

Servo drive CMMT-AS

Technical data

Electrical data						
CMMT-AS-		C2-3A-...	C4-3A-...	C2-11A-...	C3-11A-...	C5-11A-...
Output connection data						
Output voltage range	[V AC]	3x (0 – Input)				
Nominal current per phase	[A _{eff}]	2	4	1.7	2.5	5
Peak current per phase	[A _{eff}]	6	12	5.1	7.5	15
Max. peak current duration (at f _s ≥ 5 Hz)	[s]	2				
Nominal power	[W]	350	700	800	1200	2500
Peak power	[W]	1000	2000	2400	3600	7500
Output frequency	[Hz]	0 ... 599				
Max. motor cable length ¹⁾	[m]	25		50		
Load voltage AC						
Nominal operating voltage phases		Single-phase		Three-phase		
Input voltage range	[V AC]	100 –20% ... 230 +15%		200 –10% ... 480 +10%		
Nominal current	[A _{eff}]	2.8	5.6	2	3	6
Nominal power	[W]	350	700	800	1200	2500
Peak current		8.4	16.8	6	9	18
Peak power	[W]	1000	2000	2400	3600	7500
Mains frequency	[Hz]	48 ... 62				
System voltage to EN 61800-5-1	[V]	300				
Max. short circuit current rating of the mains	[kA]	100				
Mains types		TN, TT, IT				
Mains filter		Integrated				
Load voltage DC						
Input voltage range	[V DC]	80 ... 360		80 ... 700		
Max. DC link voltage	[V DC]	395		800		
Nominal current						
at 320 V DC	[A]	1.3	2.6	–	–	–
at 560 V DC	[A]	–	–	1.5	2.3	4.7
Logic supply						
Nominal voltage	[V DC]	24 ±20%				
Max. current consumption	[A]	0.5/2.3 ²⁾				0.5/2.7 ²⁾

1) Without external mains filter

2) Max. current at full expansion, with two position encoders, brake output and all I/Os with max. specified loads connected

Braking resistor						
CMMT-AS-		C2-3A-...	C4-3A-...	C2-11A-...	C3-11A-...	C5-11A-...
Integrated						
Resistance	[Ω]	100		130		
Pulse power	[kW]	1.6		5		
Pulse energy	[Ws]	230		850		
Nominal power	[W]	23		48	48	58
External						
Resistance	[Ω]	100 ... 160	70 ... 100	130 ... 250	130 ... 250	80 ... 130
Max. continuous power	[W]	180	350	400	600	1200

Motor auxiliary connections						
CMMT-AS-		C2-3A-...	C4-3A-...	C2-11A-...	C3-11A-...	C5-11A-...
Motor temperature monitoring						
Digital		Connection for temperature switch (PTC, N/C contact or N/O contact)				
Analogue		Connection for analogue temperature sensor (KTY81 ... 84, NTC, Pt1000)				
Output for holding brake						
Design		High-side switch; 24 V; monitored internally				
Output current	[A]	0.8	0.8	1.0	1.0	1.3
Output for 2nd brake						
Design		High-side switch; 24 V; monitored internally				
Output current	[A]	0.1	0.1	0.1	0.1	0.1

Servo drive CMMT-AS

Technical data

Interfaces		
Ethernet		
Function	Parameterisation and commissioning	
Protocol	DHCP	
	FTP	
	TCP/IP	
Position encoders		
Function of position encoder 1	ENDAT 2.1 encoder	
	ENDAT 2.2 encoder	
	Hiperface encoder	
	Incremental encoder	
	SIN/COS encoder	
	Nikon-A	
Function of position encoder 2	Incremental encoder	
	SIN/COS encoder	
Synchronisation		
Function	Encoder emulation A/B/Z	
	Encoder input A/B/Z	
	Pulse/direction signals CLK/DIR	
	Counting signals CW/CCW	
Encoder output, characteristics	1 MHz maximum output frequency	
	Resolution up to 16384 ppr	
Encoder input, characteristics	1 MHz maximum input frequency	
	Resolution up to 16384 ppr	
Input/output		
Digital inputs		
Number	10 ... 12 (depending on the device design)	
Number of high-speed	2	
Time resolution of high-speed	[μ s]	1
Switching logic	PNP	
Characteristics	Not galvanically isolated	
	Freely configurable in some cases	
	Safety inputs in some cases	
Specification	Based on IEC 61131-2, type 3	
Operating range	[V]	0 ... 30
Digital outputs		
Number	4 ... 6 (depending on the device design)	
Number of high-speed	2	
Time resolution of high-speed	[μ s]	1
Switching logic	PNP	
Characteristics	Not galvanically isolated	
	Freely configurable in some cases	
Max. current	[mA]	20
Analogue setpoint inputs		
Number	1	
Characteristics	Differential input	
	Configurable for current/force, rotational speed and position	
Operating range	[V]	\pm 10
Impedance	[k Ω]	70
Potential-free switching outputs		
Number	1	
Max. current	[mA]	50

Servo drive CMMT-AS

Technical data

Safety data	
Safety function to EN 61800-5-2	Safe torque off (STO)
	Safe stop 1 (SS1)
	Safe brake control (SBC)
Performance Level (PL) to EN ISO 13849-1	
Safe torque off (STO)	Category 4, performance Level e
Safe brake control (SBC)	Category 3, performance Level e
Safety integrity level (SIL) to EN 62061 and EN 61508	
Safe torque off (STO)	SIL 3/SILCL 3
Safe brake control (SBC)	SIL 3/SILCL 3
Certificate issuing authority and no.	TÜV Rheinland (German Technical Control Board) 01/205/5640.00/18
Proof test interval	
Safe torque off (STO)	Up to 20a
Safe brake control (SBC)	24 h
Diagnostic coverage [%]	Up to 97
Safe failure fraction (SFF) [%]	Up to 99
Hardware fault tolerance	1

Operating and environmental conditions	
Degree of protection	IP20
Ambient temperature ¹⁾ [°C]	0 ... +50
Storage temperature [°C]	-25 ... +55
Relative humidity [%]	5 ... 90 (non-condensing)
Protection class	I
Overvoltage category	III
Contamination level	2
Surge resistance [kV]	6
Max. installation height ²⁾ [m]	2000
Shock and vibration resistance	To EN 61800-2 and EN 61800-5-1
CE marking (see declaration of conformity)	To EU EMC Directive ³⁾
	To EU Machinery Directive
	To EU Low Voltage Directive
	To EU RoHS Directive
Certification	c UL us - Listed (OL)
	RCM trademark
Note on materials	Contains PWIS (paint-wetting impairment substances)
	RoHS-compliant

1) Above 40 °C power is reduced by 3% per K.

2) Above 1000 m power is reduced by 1% per 100 m.

3) For information about the applicability of the component see the manufacturer's EC declaration of conformity at: www.festo.com/sp → User documentation.

If the component is subject to restrictions on usage in residential, office or commercial environments or small businesses, further measures to reduce the emitted interference may be necessary.

Servo drive CMMT-AS

Technical data

View of servo drive

Front view

CMMT-AS-...-3A

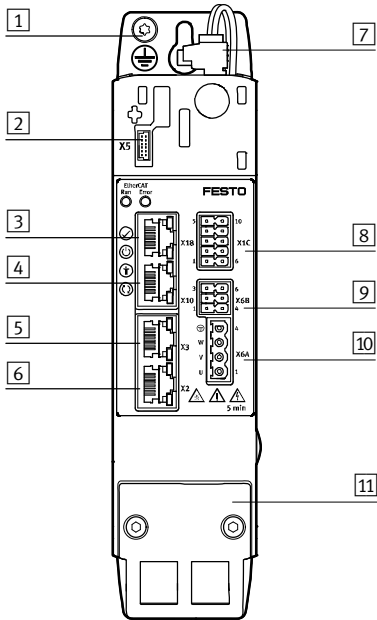

CMMT-AS-...-11A

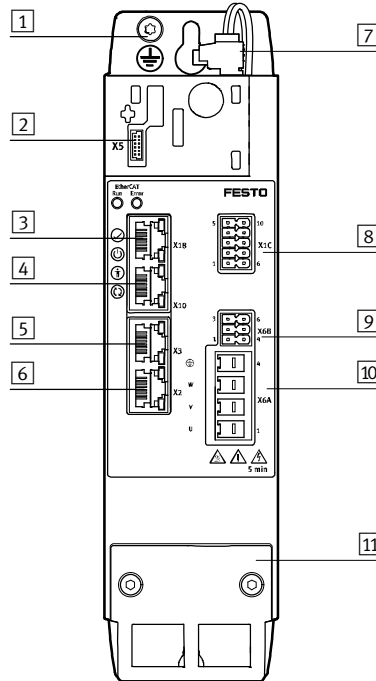

- 1 PE connection for housing
- 2 [X5] Connection for control unit (behind blanking plate)
- 3 [X18] Standard Ethernet
- 4 [X10] Device synchronisation
- 5 [X3] Position sensor 2
- 6 [X2] Position sensor 1
- 7 [X9B] Connection for braking resistor
- 8 [X1C] Inputs/outputs for axis
- 9 [X6B] Motor auxiliary connection
- 10 [X6A] Motor phase connection
- 11 Shield clamp and strain relief

Top view

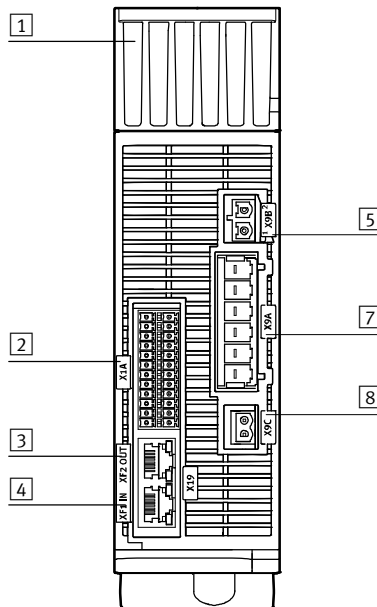
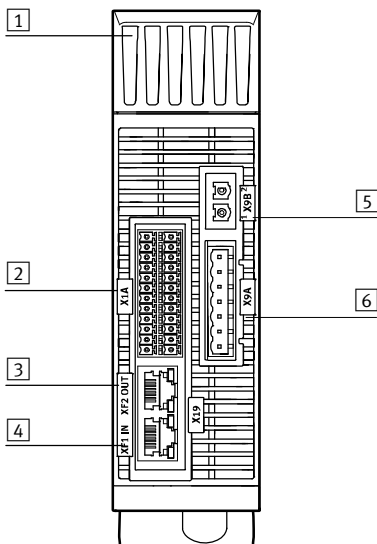

- 1 Cooling element
- 2 [X1A] I/O interface
- 3 [XF2 OUT] RTE interface port 2
- 4 [XF1 IN] RTE interface port 1
- 5 [X9B] Connection for braking resistor
- 6 [X9A] Supply: mains, DC link and logic voltage
- 7 [X9A] Supply: mains and DC link voltage
- 8 [X9C] Supply: logic voltage

Servo drive CMMT-AS

Technical data

Installation clearance for servo drive

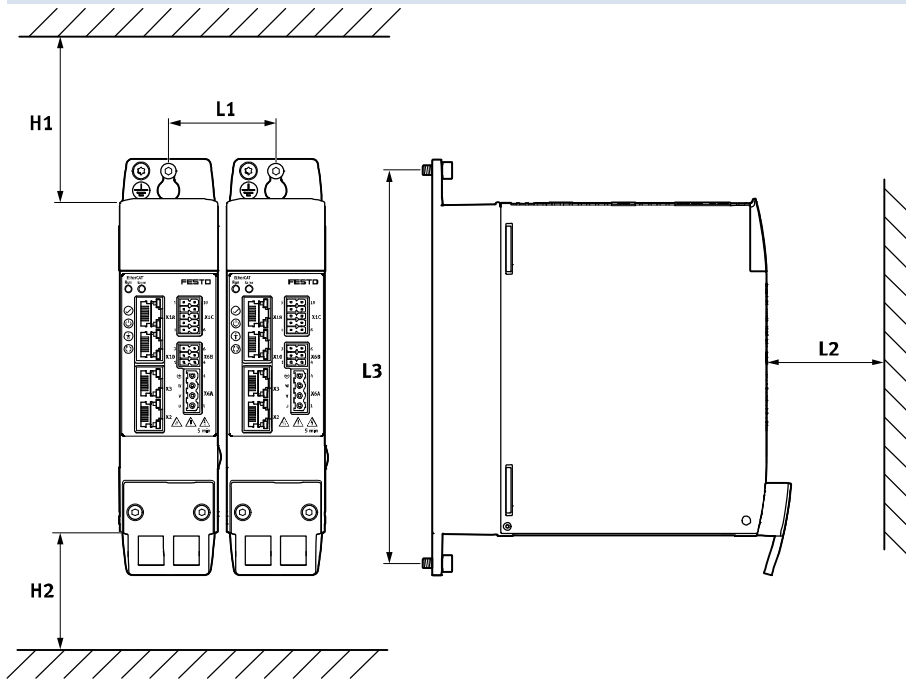

Type	H1	H2 ¹⁾	L1	L2	L3
CMMT-AS-...	70	70	52	70	200

1) An installation clearance of 150 mm underneath the servo drive is recommended for optimum wiring of the motor or encoder cable

Servo drive CMMT-AS

Technical data

Dimensions

Download CAD data → www.festo.com

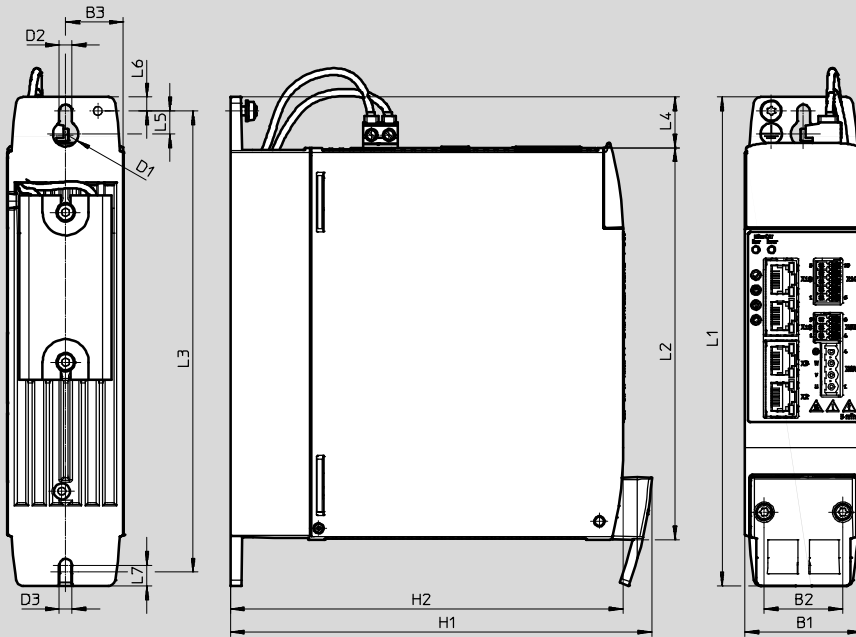

Type	B1	B2	B3	D1	D2	D3	H1	H2
CMMT-AS-...-3A	50	34	25	11	5.5	5.5	183	170
CMMT-AS-...-11A-P3	60	42	29.7	11	5.5	5.5	218	205

Type	L1	L2	L3	L4	L5	L6	L7
CMMT-AS-...-3A	212	170	200	22	10	6	9
CMMT-AS-...-11A-P3	242	200	220	22	10	6	16

Ordering data

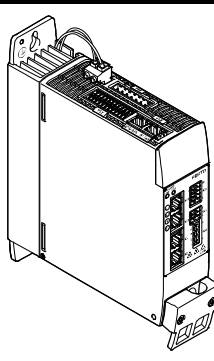
	Description	Number of phases	Nominal current	Part no.	Type	
	The assortment of plugs NEKM (→ page 13) is not included in the scope of delivery of the servo drive.	Bus protocol: EtherCAT				
		Single-phase	2		5340819	CMMT-AS-C2-3A-EC-S1
			4		5340820	CMMT-AS-C4-3A-EC-S1
		Three-phase	2		5340821	CMMT-AS-C2-11A-P3-EC-S1
			3		5340822	CMMT-AS-C3-11A-P3-EC-S1
			5		5340823	CMMT-AS-C5-11A-P3-EC-S1
		Bus protocol: PROFINET RT/IRT				
		Single-phase	2		5340814	CMMT-AS-C2-3A-PN-S1
			4		5340815	CMMT-AS-C4-3A-PN-S1
		Three-phase	2		5340816	CMMT-AS-C2-11A-P3-PN-S1
			3		5340817	CMMT-AS-C3-11A-P3-PN-S1
			5		5340818	CMMT-AS-C5-11A-P3-PN-S1

Servo drive CMMT-AS

Ordering data – Modular product system

Ordering table					
Series			Condi- tions	Code	Enter code
CMMT-AS-...	-3A	-11A			
M Module no.	5111184	5111189			
Series	CMMT			CMMT	CMMT
Motor type	AC synchronous			-AS	-AS
Nominal current					
2 A				-C2	
3 A	-			-C3	
4 A		-		-C4	
5 A	-			-C5	
Nominal input voltage					
230 V AC/50-60 Hz		-		-3A	
400 V AC	-			-11A	
O Number of phases					
Single-phase		-			
Three-phase	-			-P3	
M Bus protocol/activation	EtherCAT			-EC	
	PROFINET RT/IRT			-PN	
Safety function	Standard safety			-S1	-S1

- M** Mandatory data
- O** Options

Transfer order code

-

-

-

-

-

-

Servo drive CMMT-AS

Accessories

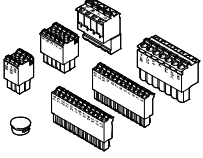
Ordering data – Required accessories			
	Description	Part no.	Type
Assortment of plugs			
	For single wiring connection with single-phase servo drives	4325822	NEKM-C6-C16-S
	For double wiring connection with single-phase servo drives	5054513	NEKM-C6-C16-D
	For single wiring connection with three-phase servo drives	5119205	NEKM-C6-C45-P3-S
	For double wiring connection with three-phase servo drives	5118001	NEKM-C6-C45-P3-D
	Not included in the scope of delivery of the servo drive.		

Ordering data – Optional accessories

Control unit CDSB-A1

- Display of full-text messages. This means that errors, warnings and selected data can be read at a glance
 - Easy data backup of parameters and firmware in the unit for e.g. serial commissioning or device replacement
 - One control unit can be used for several servo drives
 - Control element: touchscreen
 - Display: colour TFT
 - Display size: 1.77"
 - User memory: 3 GB
 - USB interface: USB 2.0 type mini
- Additional technical data:
 → Internet: cdsb

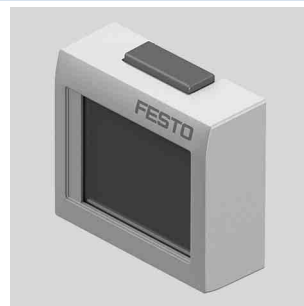

Ambient temperature [°C]	Storage temperature [°C]	Degree of protection	Weight [g]	Part no.	Type
0 ... 60	-20 ... +70	IP20	40	8070984	CDSB-A1
Not included in the scope of delivery of the servo drive					

Ordering data – Optional accessories

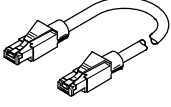
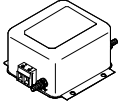
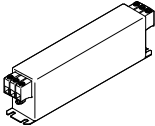
	Description	Part no.	Type
Connecting cable			
	<ul style="list-style-type: none"> • Patch cable for the daisy-chain connection of the bus interfaces X19A/B • Not included in the scope of delivery of the servo drive 	8082383	NEBC-R3G8-KS-Q2-N-S-R3G8-ET
Mains filters			
	Single-phase, 8 A, sufficient for: 2x CMMT-AS-C2-3A or 1x CMMT-AS-C4-3A	8088928	CAMF-C6-F-C8-3A
	Single-phase, 20 A, sufficient for: 6x CMMT-AS-C2-3A or 3x CMMT-AS-C4-3A	8088929	CAMF-C6-F-C20-3A
	Three-phase, 16 A, sufficient for: 8x CMMT-AS-C2-11A or 5x CMMT-AS-C3-11A or 2x CMMT-AS-C5-11A	8096868	CAMF-C6-F-C16-11A
	Three-phase, 42 A, sufficient for: 21x CMMT-AS-C2-11A or 14x CMMT-AS-C3-11A or 7x CMMT-AS-C5-11A	8096894	CAMF-C6-F-C42-11A
Not included in the scope of delivery of the servo drive			

Servo drive CMMT-AS

Accessories

FESTO

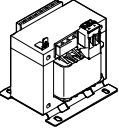
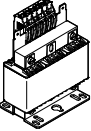
Ordering data – Optional accessories			
	Description	Part no.	Type
Filter flow control			
	Single-phase, 6 A, sufficient for: 2x CMMT-AS-C2-3A or 1x CMMT-AS-C4-3A	8088930	CAMF-C6-FD-C6-3A
	Three-phase, 6 A, sufficient for: 3x CMMT-AS-C2-11A or 2x CMMT-AS-C3-11A or 1x CMMT-AS-C5-11A	8096867	CAMF-C6-FD-C6-11A
Not included in the scope of delivery of the servo drive			

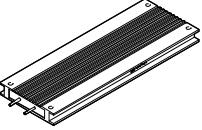
Ordering data – Optional accessories							Technical data → Internet: cacr		
	For type CMMT-AS-					Resistance value [Ω]	Nominal power [W]	Part no.	Type
	C2-3A	C4-3A	C2-11A	C3-11A	C5-11A				
Braking resistor									
	-	■	-	-	-	72	200	1336611	CACR-LE2-72-W500
	■	■	-	-	■	100	200	1336615	CACR-LE2-100-W500
	-	-	■	■	-	240	200	8091543	CACR-LE2-240-W500
	-	-	■	■	-	240	720	8091544	CACR-KL2-240-W1800
	-	-	-	-	■	100	720	8091545	CACR-KL2-100-W1800
Not included in the scope of delivery of the servo drive									

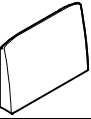
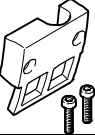
Ordering data – Optional accessories					
	Description	For CMMT-AS-...		Part no.	Type
		-3A	-11A		
Blanking plate					
	<ul style="list-style-type: none"> Used to cover the connections if no control unit used Included in the scope of delivery of the servo drive 	■	■	5395254	CAFC-06-C
Shield clamp					
	<ul style="list-style-type: none"> For clamping the shield and strain relief for the motor cable Included in the scope of delivery of the servo drive 	■	-	5326867	CAMA-C6-SK-S2
		-	■	5335956	CAMA-C6-SK-S3

Festo - Your Partner in Automation



1 Festo Inc.
5300 Explorer Drive
Mississauga, ON L4W 5G4
Canada

Festo Customer Interaction Center
Tel: 1 877 463 3786
Fax: 1 877 393 3786
Email: customer.service.ca@festo.com

2 Festo Pneumatic
Av. Ceylán 3,
Col. Tequesquináhuac
54020 Tlalnepantla,
Estado de México

Multinational Contact Center
01 800 337 8669
ventas.mexico@festo.com

3 Festo Corporation
1377 Motor Parkway
Suite 310
Islandia, NY 11749

Festo Customer Interaction Center
1 800 993 3786
1 800 963 3786
customer.service.us@festo.com

4 Regional Service Center
7777 Columbia Road
Mason, OH 45040

Connect with us



www.festo.com/socialmedia



www.festo.com

Subject to change