

Valve series VOFD

FESTO



Solenoid valves VOFD

Key features

FESTO

General

- The valves from the series VOFD are special 3/2-way valves for process automation, for use in chemical and petrochemical plants. Here they are frequently used as pilot valves for butterfly valves and actuators. Their sturdy design and high resistance to corrosion make these valves suitable for outdoor use under harsh ambient conditions.
- The NAMUR flange pattern makes the solenoid valves especially suitable for quarter-turn actuators. The integrated spring chamber re-breather function protects quarter-turn actuators with spring return (single-acting cylinders and actuators) against contaminated ambient air and weather influences such as rain.
- With German Technical Control Board (TÜV) approval up to SIL 3.

Function, design

- 3/2-way directly actuated poppet valves

Safety

- Can be used in emergency shutdown (ESD) applications
- Suitable for use in safety-related systems up to and including SIL 3 to IEC 61508

Robust

- The surface of the valve housing is Ematal coated. This treatment involves converting the aluminium surface into a very hard aluminium oxide layer with titanium oxide intercalations, which makes the valves extremely resistant to wear and abrasion and gives them first-class sliding qualities. This provides optimum protection against atmospheric and chemical influences.
- You can find information on the media resistance of the product at → www.festo.com.

Economical

- One valve, two connection options
- Port patterns to NAMUR for direct installation on the actuator as well as G and NPT threaded connections
- Manual override can be ordered optionally
- Manual override can be retrofitted and removed again – no additional valve version required

Ordering data – Product options

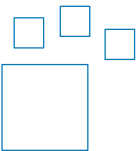

Configurable product
This product and all its product options can be ordered using the configurator.

The configurator can be found under Products on the DVD or at
→ www.festo.com/catalogue/...

Part No.	Type
2956784	VOFD-L35T
3212962	VOFD-L50T
2964753	VOFD-L100T

Solenoid valves VOFD

Key features

FESTO

VOFD – Basic valves

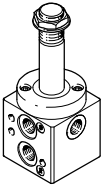

- 3/2-way valves
- Ports G $\frac{1}{4}$, $\frac{1}{4}$ NPT, G $\frac{1}{2}$, $\frac{1}{2}$ NPT
- Port pattern to NAMUR, port pattern to NAMUR with P duct

→ Page 18

VACC – S18 coils, VACC – S13 coils

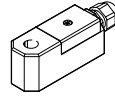

- AC and DC voltage 24 V, 48 V, 60 V, 110 V, 120 V, 230 V
- Type of ignition protection EX EMB II, EX tD

→ Internet: vacc

VOFD – Solenoid valves

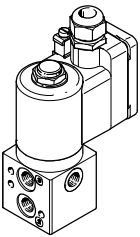

- Combination of VOFD basic valve and VACC-S18 coil (in the case of basic valve VOFD-L12T-..., VACC-S13 coil)
- 3/2-way valves
- Type of ignition protection EX EMB II, EX tD

Configurable product

→ Page 2

VOFD – Accessories



- Flow control plate
- Sub-base
- Mounting plate
- Connection kit
- Adapter with filter
- Exhaust protection
- Mounting bracket
- Manual override

→ Page 31

Solenoid valves VOFD-L35/50/100T...-F10

Peripherals overview

FESTO

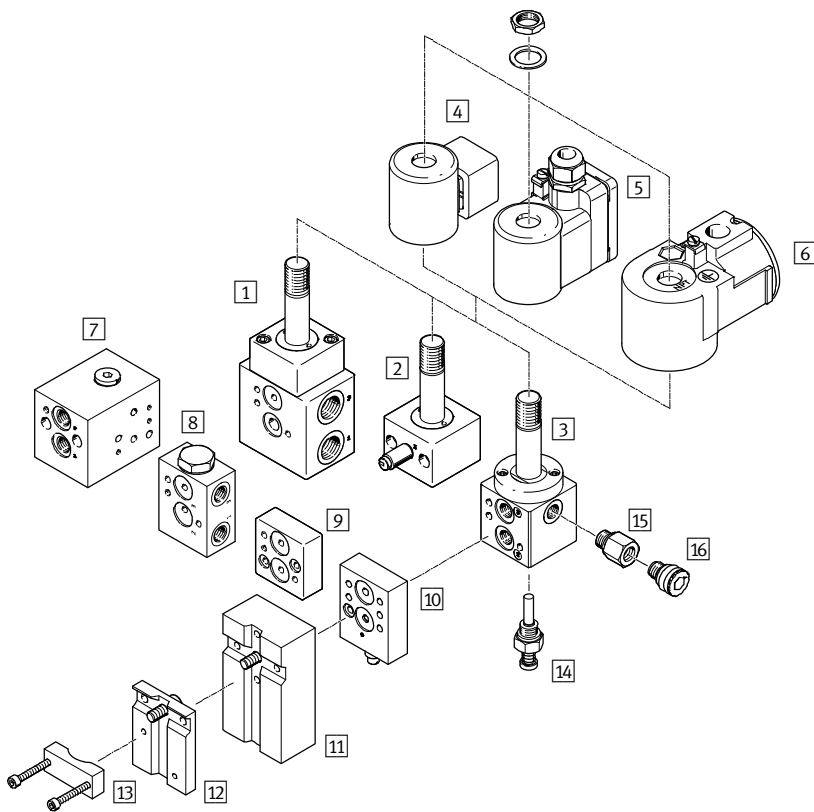

Mounting components and accessories		
	Brief description	→ Page/Internet
1	Basic valve VOFD-L100T-... → modular product system – can be configured using the online configurator	2
2	Basic valve VOFD-L35T-... → modular product system – can be configured using the online configurator	2
3	Basic valve VOFD-L50T-... → modular product system – can be configured using the online configurator	2
4	Solenoid coil VACC-S18-...-A1-...	29
5	Solenoid coil VACC-S18-...-ME	29
6	Solenoid coil VACC-S18-...-D	29
7	Sub-base VABS-S7-RB-...	31
8	Connecting plate VABS-S7-BE-...	31
9	Mounting plate VAME-S7-P-N-V14-A	37
10	Flow control plate VABF-S7-F1B5P1-F	34
11	Connection kit VABF-S7-S-G14	35
12	Mounting plate VAME-S7-P	34

Solenoid valves VOFD-L12T-...-F19/F19A

Peripherals overview

FESTO

Mounting components and accessories			
	Brief description	→ Page/Internet	
13	Mounting bracket VAME-S7-Y	Alternative option (instead of screw) for attaching the valve to a NAMUR rib with the help of a mounting bracket	35
14	Manual override VAOH-S8	Manual override	37
15	Adapter NPFV-AF-...-MF	Adapter with filter	36
16	Exhaust protection VABD-D3-SN-G14	Exhaust protection to IP65. The spring chamber of the solenoid valve is protected against the ingress of aggressive ambient air and water by the one-way flow control system	36

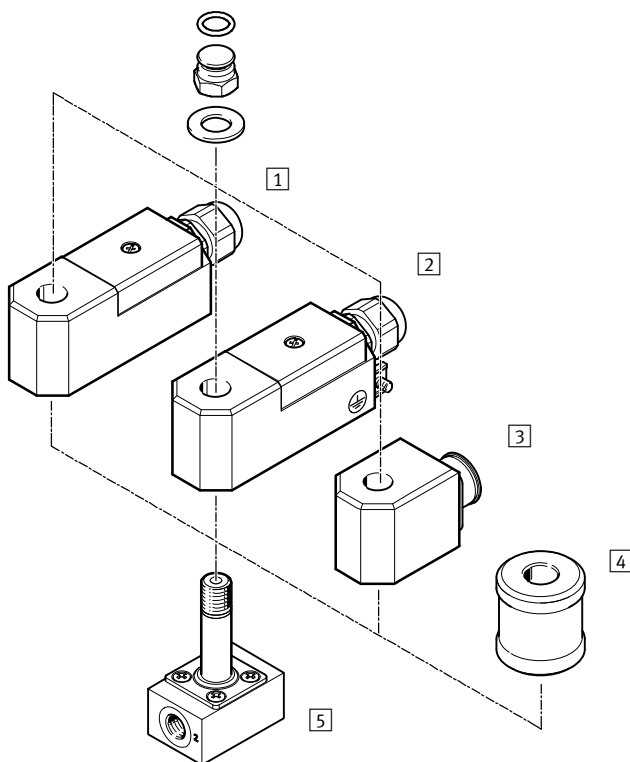

Accessories: Valve pilot control interface for solenoid coil 13 mm			
	Brief description	→ Page/Internet	
1	Solenoid coil VACC-S13-...-4A	EX-4A solenoid	30
2	Solenoid coil VACC-S13-...-ME	Ex-ME solenoid	30
3	Solenoid coil VACC-S13-...-A1-...	A1 standard solenoid	30
4	Manual override VAOH-MB-S7-S13	Manual override (MO)	37
5	Basic valve VOFD-L12T-...	3/2-way valve, port G1/4, poppet valve, valve pilot control interface for solenoid coil 13 mm	9

Solenoid valves VOFD

Type codes VOFD

VOFD - L - T - - M N - - - -

Type	
VOFD	Solenoid valves, series D
Valve type	
L	In-line valve
Nominal width	
12	1.2 mm
35	3.5 mm
40	4 mm
50	5 mm
100	10 mm
Design principle	
T	Poppet valve
Valve function	
M32	3/2-way valve, normally closed or open
M32A	3/2-way valve, normally closed, semi-automatic
Reset method for single solenoid valves	
M	Mechanical spring
Pilot air	
N	None
Manual override	
-	None
H	Non-detenting
Y	Detenting without accessories
Pneumatic connection	
G12	G1/2
G14	G1/4
N12	1/2 NPT
N14	1/4 NPT
FG12	Flange G1/4, ports G1/2
FG14	Flange G1/4, ports G1/4
FGP14	Flange G1/4, ports G1/4 and additional pn port (NAMUR)
FNP14	Flange 1/4 NPT and additional pn port (NAMUR)
Supply port version	
-	Standard
PF	With particle filter
NPF	With particle filter and connecting thread NPT
Exhaust	
-	No fitting
U6	With exhaust protection

Solenoid valves VOFD

Type codes VOFD

Pressure range							
8	0 ... 8 bar						
10	0 ... 10 bar						
12	0 ... 12 bar						
Temperature range							
-	Standard						
T6	-50 ... +60 °C						
Corrosion protection							
-	Standard						
R1	Stainless steel						
Valve pilot control interface							
F10	Electric with armature tube for solenoid coil 18 mm						
F19	Electric with armature tube for solenoid coil 13 mm						
F19A	Electric with armature tube for solenoid coil 13 mm, intrinsically safe						
Power consumption							
-	None						
18	1.8 W						
25	2.5 W						
35	3.5 W						
70	7 W						
120	12 W						
Nominal operating voltage							
-	None						
1A	24 V AC/50-60 Hz						
1U	24 V AC and DC						
2A	110 V AC/50-60 Hz						
2U	110 V AC and DC						
3A	220 VAC/50-60 Hz						
3U	220 V AC and DC						
7U	48 V AC and DC						
16U	120 V AC and DC						
1	24 V DC						
3	230 V DC						
7	48 V DC						
16	120 V DC						
27	60 V DC						
Electrical connection							
-	None						
A1	Plug pattern type A, to EN 175301						
K4	Cable connector, metric						
K5	Cable connector NPT						

Solenoid valves VOFD

Type codes VOFD

		[] - [] - [] - []
Circuitry		
-	None	
F	Fuse	
EU certification		
-	Without certification	
EX4	II 2GD	
Certification outside the EU		
-	Without certification	
U2	cULus, hazardous environment, USA and Canada (NEC 500)	
Type of ignition protection		
-	None	
A	Intrinsically safe	
D	Pressure-resistant encapsulation	
ME	Moulded encapsulation, enhanced safety	

Basic valves VOFD-L12T-...-F19/F19A

Technical data – Basic valve VOFD-L12T-...

Function
3/2-way valve

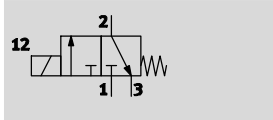

 Flow rate
Up to 52 l/min



General technical data		
Basic valve G1/4	VOFD- ... -F19	VOFD- ... -F19-A
Valve function	3/2-way, single solenoid, closed	
Pneumatic connection	1	G1/4
	2	G1/4
	3	G1/4
Design	Directly actuated poppet valve	
Width [mm]	50	
Mounting position	Any	
Sealing principle	Soft	
Manual override	None	
Reset method	Mechanical spring	
Type of actuation	Electrical	
Suitability for vacuum	Yes	
Type of control	Direct	
Flow rate for piston valve pressurisation [m ³ /h]	0.04	
Flow rate for piston valve exhausting [m ³ /h]	0.04	
b value	0.2	0.53
C value [l/s bar]	0.44	0.21
Direction of flow	Non-reversible	
Product weight [g]	170	
Switching time off [ms]	60	
Switching time on [ms]	40	
Nominal width [mm]	1.2	
Standard nominal flow rate [l/min]	52	
Standard nominal flow rate 2→3 [l/min]	49	

Operating and environmental conditions	
Operating medium	Compressed air to ISO 8573-1:2010 [7:-:-]
Operating pressure range [bar]	0 ... 8
Temperature of medium [°C]	-25 ... +60
Ambient temperature [°C]	-25 ... +60
Corrosion resistance class CRC ¹⁾	4

1) Corrosion resistance class CRC 4 to Festo standard FN 940070
Particularly high corrosion stress. Outdoor exposure under extreme corrosive conditions. Parts exposed to aggressive media, for instance in the chemical or food industries. These applications may need to be supported by special tests (→ also FN 940082) using appropriate media.

Materials	
Housing	Aluminium (Ematal coated)
Seals	NBR
Note on materials	Contains paint-wetting impairment substances, RoHS-compliant

Basic valves VOFD-L12T-...-F19/F19A

Technical data – Basic valve VOFD-L12T-...

Download CAD data → www.festo.com

3 Pneumatic connection 3

Type	B1	B2	D1	D2	H1	H2	H4	H5	L1	L2	T1
VOFD-L12T-M32-MN-G14-F19	33	15	G1/4	M5	85	12	24	27.5	50	25	6
VOFD-L12T-M32-MN-G14-F19-A											

Ordering data						
Circuit symbol	Function	Pneumatic connection	Type of ignition protection	Part No.	Type	
Directly actuated poppet valve						
	3/2-way, single solenoid, closed	G1/4	None	3013904	VOFD-L12T-M32-MN-G14-F19	
			Intrinsically safe	3014556	VOFD-L12T-M32-MN-G14-F19A	

Basic valves VOFD-L35T-...-F10

Technical data – Modular system NW 3.5 mm

Function
3/2-way valve

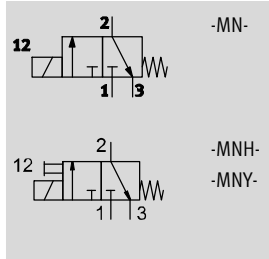

-  - Flow rate
Up to 406 l/min



General technical data				
Basic valve G1/4		VOFD-L35T-...-MN-...	VOFD-L35T-...-MNH-...	VOFD-L35T-...-MNY-...
Valve function		3/2-way, single solenoid, closed (M32)		
		3/2-way, single solenoid, closed, semi-automatic (M32A)		
Pneumatic connection VOFD-...-G14	1	G1/4		
	2	G1/4		
	3	G1/4		
Pneumatic connection VOFD-...-N14	1	1/4 NPT		
	2	1/4 NPT		
	3	1/4 NPT		
Design		Directly actuated poppet valve		
Width	[mm]	51 (50 stainless steel design)		
Mounting position		Any		
Sealing principle		Soft		
Manual override		None	Non-detenting	Detenting
Type of reset		Mechanical spring		
Type of actuation		Electrical		
Suitability for vacuum		No		
Type of control		Direct		
Flow rate for piston valve pressurisation	[m ³ /h]	0.32		
Flow rate for piston valve exhausting	[m ³ /h]	0.32		
b value		0.15		
C value		1.8		
Direction of flow		Non-reversible		
Product weight	[g]	390		
Switching time off	[ms]	60		
Switching time on	[ms]	40		
Nominal width		3.5		
Standard nominal flow rate 1 → 2		[l/min]	406	
Standard nominal flow rate 2 → 3		[l/min]	440	

Selection of solenoid coils

Suitable solenoid coils for the basic valves are available in the section on accessories.

The following solenoid coils can be selected:

- S18-18, nominal power 3 watt at 230 V AC (Ex-D)
- S18-70, nominal power 7 watt at 24 V DC (Ex-D)
- S18-120, nominal power 12 watt at 24 V DC (Ex-ME)

-  - Note

Additional information and solenoid coils to fit basic valves can be found in the Festo online configurator.

➔ Internet: VACC
➔ www.festo.com/sp

Basic valves VOFD-L35T-...-F10

FESTO

Technical data – Modular system NW 3.5 mm

Operating and environmental conditions	
Operating medium	Compressed air to ISO 8573-1:2010 [7:-:-]
Operating pressure range [bar]	0 ... 8
Temperature of medium [°C]	-25 ... +60
Temperature of medium, low temperature [°C]	-50 ... +60
Ambient temperature [°C]	-25 ... +60
Ambient temperature, low temperature [°C]	-50 ... +60
Corrosion resistance class CRC ¹⁾	4

1) Corrosion resistance class CRC 4 to Festo standard FN 940070

Particularly high corrosion stress. Outdoor exposure under extreme corrosive conditions. Parts exposed to aggressive media, for instance in the chemical or food industries. These applications may need to be supported by special tests (➔ also FN 940082) using appropriate media.

Materials	
Housing	Aluminium (Ematal coated)
Stainless steel housing	High-alloy stainless steel
Seals	NBR
Low temperature seals, stainless steel	VMQ
Note on materials	Contains paint-wetting impairment substances, RoHS-compliant

Basic valves VOFD-L35T-...-F10

Technical data – Modular system NW 3.5 mm

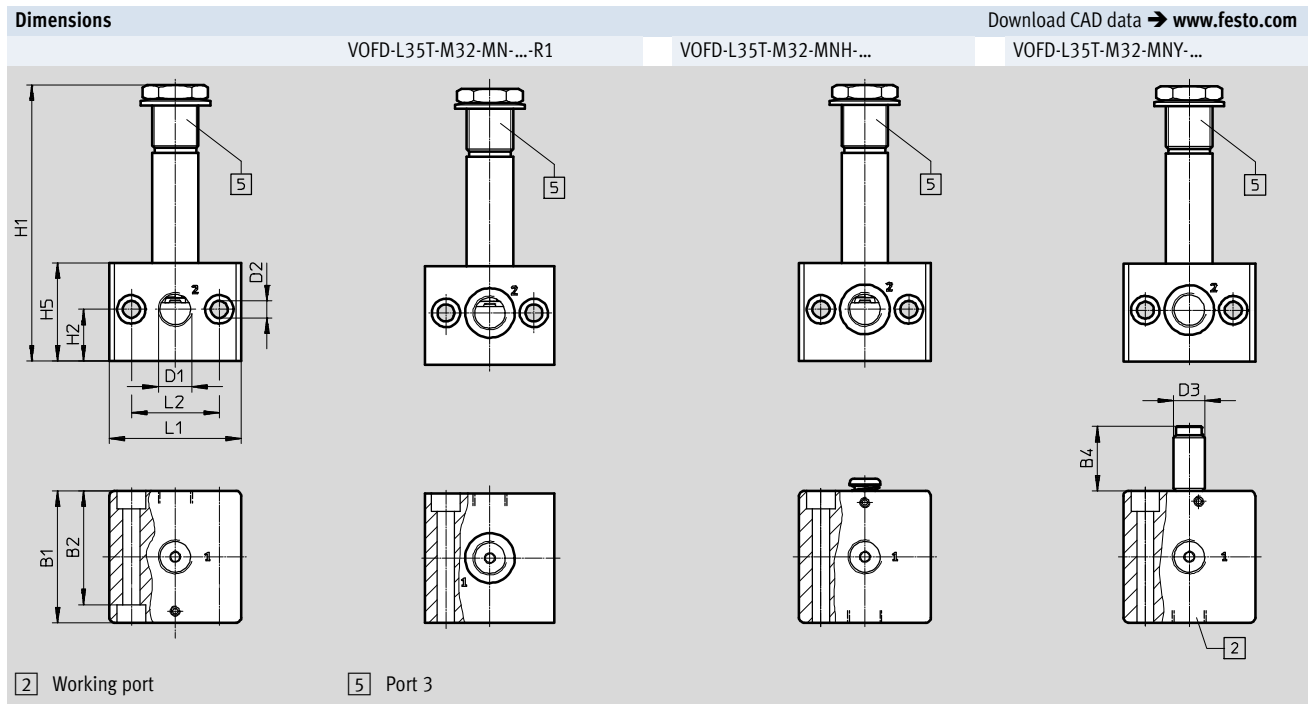

Type of G thread	B1	B2	B4	D1	D2 ∅	D3 ∅	H1	H2	H5	L1	L2
VOFD-L35T-M32-MN-G14-...-F10	51	44	–	G1/4	6.6	–	106.5	20	38	51	34
VOFD-L35T-M32-MN-G14-...-R1-F10	50	43	–			–					
VOFD-L35T-M32-MNH-G14-...-F10	51	44	–			–					
VOFD-L35T-M32-MNY-G14-...-F10	51	44	25			12					

Type of NPT thread	B1	B2	B4	D1	D2 ∅	D3 ∅	H1	H2	H5	L1	L2
VOFD-L35T-M32-MN-N14-...-F10	51	44	–	1/4 NPT	6.6	–	106.5	20	38	51	34
VOFD-L35T-M32-MN-N14-...-R1-F10	50	43								50	
VOFD-L35T-M32-MNH-N14-...-F10	51	44								51	
VOFD-L35T-M32A-MNH-N14-...-F10	51	44								51	
VOFD-L35T-M32A-MNH-N14-...-R1-F10	50	43								50	

Basic valves VOFD-L50T-...-F10

Technical data – Modular system NW 5 mm

FESTO

Function
3/2-way valve

 Flow rate
Up to 493 l/min

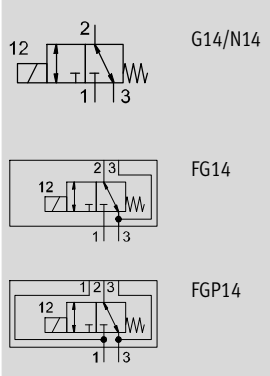

General technical data				
Basic valve G1/4		VOFD-L50T-...G14-... VOFD-L50T-...N14-...	VOFD-L50T-...-FG14-... VOFD-L50T-...-FGP14-...	VOFD-L50T-...G14-R1-... VOFD-L50T-...N14-R1-...
Valve function		3/2-way, single solenoid, closed		
Pneumatic connection VOFD-...-G14	1	G1/4		
	2	G1/4		
	3	G1/4		
Pneumatic connection VOFD-...-N14	1	1/4 NPT		
	2	1/4 NPT		
	3	1/4 NPT		
Pneumatic connection VOFD-...-FG14	1	G1/4		
	2	Port pattern to NAMUR, flange 1/4		
	3	G1/4		
Pneumatic connection VOFD-...-FGP14	1	M5 port pattern to NAMUR		
	2	Port pattern to NAMUR, flange 1/4		
	3	G1/4		
Design		Directly actuated poppet valve		
Width	[mm]	51	50.5 (flange thread)	28 (stainless steel design)
Mounting position		Any		
Sealing principle		Soft		
Manual override		None		
Reset method		Mechanical spring		
Type of actuation		Electrical		
Suitability for vacuum		Yes		
Type of control		Direct		
Flow rate for piston valve pressurisation	[m ³ /h]	0.36		
Flow rate for piston valve exhausting	[m ³ /h]	0.36		
b value		0.25		
C value	[l/s bar]	2		
Direction of flow		Reversible		
Product weight	[g]	560		
Switching time off	[ms]	60		
Switching time on	[ms]	40		
Nominal width	[mm]	5		
Standard nominal flow rate	[l/min]	493		
Standard nominal flow rate 2→3	[l/min]	429		

Basic valves VOFD-L50T-...-F10

Technical data – Modular system NW 5 mm

Selection of solenoid coils

Suitable solenoid coils for the basic valves are available in the section on accessories.

The following solenoid coils can be selected:

- S18-25, nominal power 2.5 watt at 24 V DC (Ex-D)
- S18-35, nominal power 3.5 watt at 24 V DC (Ex-ME)

 Note

Additional information and solenoid coils to fit basic valves can be found in the Festo online configurator.

→ Internet: VACC
→ www.festo.com/sp

Operating and environmental conditions

Operating medium		Compressed air to ISO 8573-1:2010 [7:2:2]
Operating pressure range	[bar]	0 ... 10
Temperature of medium	[°C]	-25 ... +60
Ambient temperature	[°C]	-25 ... +60
Extended ambient temperature, Low Demand mode	[°C]	-25 ... +60
Safety integrity level	[SIL]	Up to SIL 3 Low Demand mode
Corrosion resistance class CRC ¹⁾		4

1) Corrosion resistance class CRC 4 to Festo standard FN 940070
Particularly high corrosion stress. Outdoor exposure under extreme corrosive conditions. Parts exposed to aggressive media, for instance in the chemical or food industries. These applications may need to be supported by special tests (→ also FN 940082) using appropriate media.

Materials

Housing	Aluminium (Ematal coated)
Stainless steel housing	High-alloy stainless steel
Seals	NBR
Note on materials	Contains paint-wetting impairment substances, RoHS-compliant

Basic valves VOFD-L50T-...-F10

Technical data – Modular system NW 5 mm

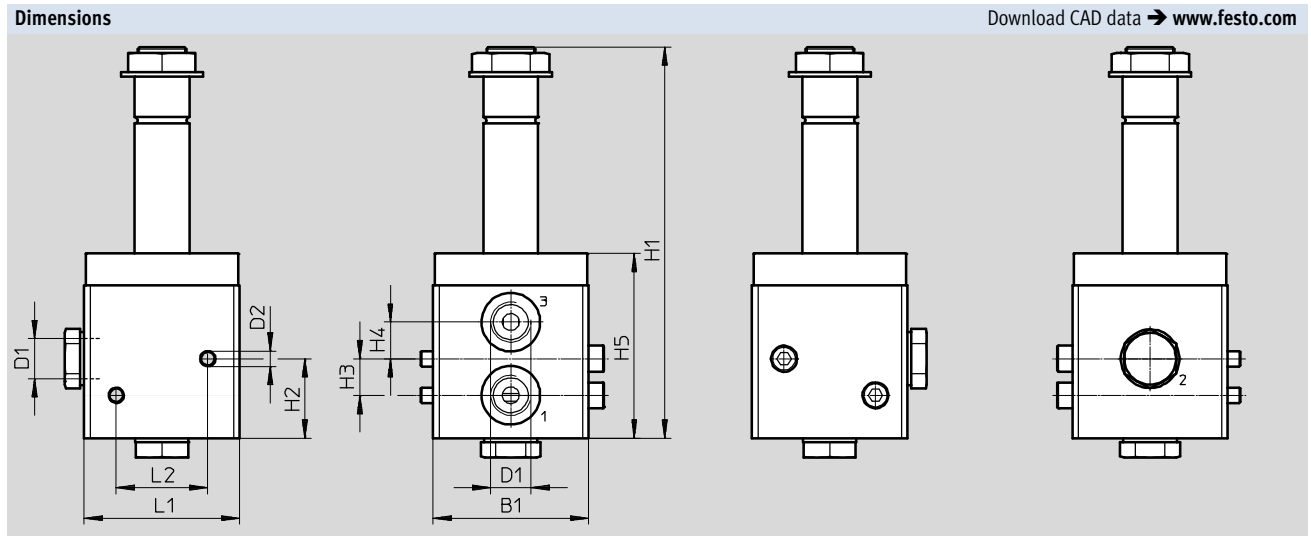

Type of G thread	B1	D1	D2 Ø	H1	H2	H3	H4	H5	L1	L2
VOFD-L50T-M32-MN-G14-...-F10	51	G1/4	5.5	128	26	12	12	60.5	51	30

Type of NPT thread	B1	D1	D2 Ø	H1	H2	H3	H4	H5	L1	L2
VOFD-L50T-M32-MN-N14-...-F10	51	1/4 NPT	5.5	128	26	12	12	60.5	51	30

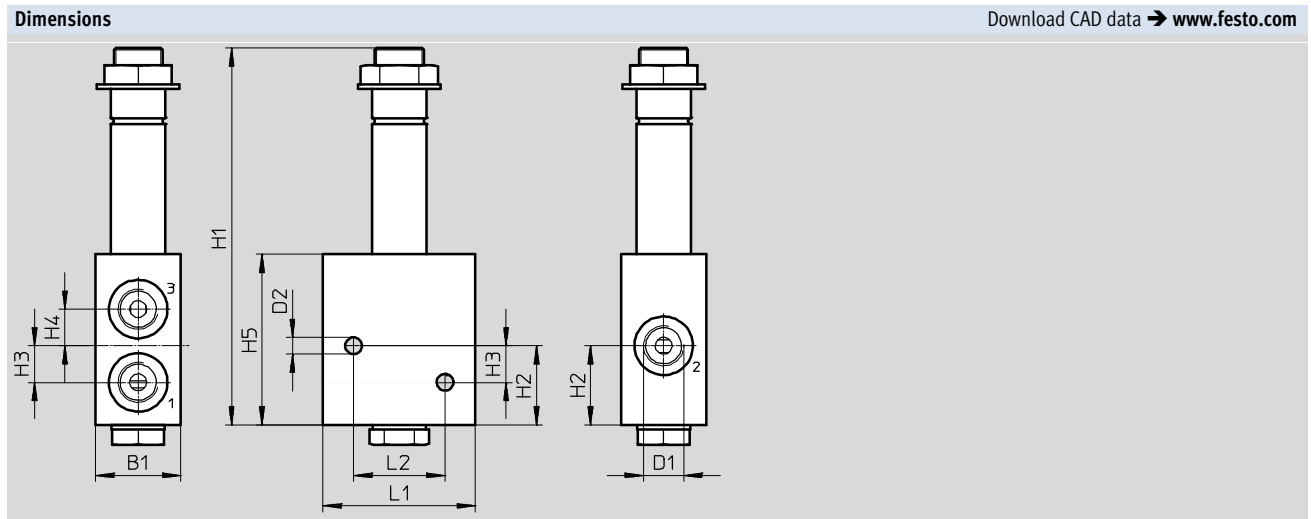

Type of G thread	B1	D1	D2 Ø	H1	H2	H3	H4	H5	L1	L2
VOFD-L50T-M32-MN-G14-...-R1-F10	28	G1/4	5.5	124	26	12	12	56	50	30

Type of NPT thread	B1	D1	D2 Ø	H1	H2	H3	H4	H5	L1	L2
VOFD-L50T-M32-MN-N14-...-R1-F10	28	1/4 NPT	5.5	124	26	12	12	56	50	30

Basic valves VOFD-L50T-...-F10

Technical data – Modular system NW 5 mm

Dimensions

Download CAD data → www.festo.com

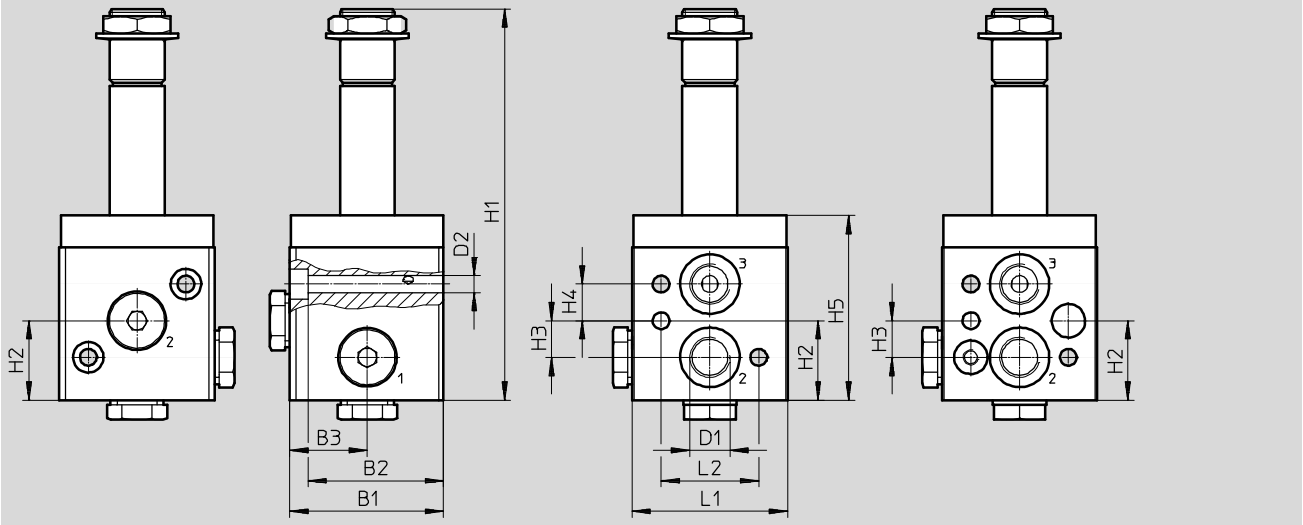

Type of flange thread	B1	B2	B3	D1	D2 Ø	H1	H2	H3	H4	H5	L1	L2
VOFD-L50T-M32-MN-FG14-F10	50.5	44.5	25.5	G1/4	5.5	128	26	12	12	60.5	51	32
VOFD-L50T-M32-MN-FGP14-F10												

Basic valves VOFD-L50T-...-F10

Technical data – Basic valve NW 5 mm, G1/4 NAMUR

FESTO

Function
3/2-way valve

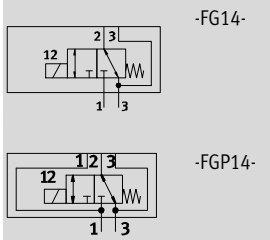

Flow rate
450 l/min (-LT-M32-)
493 l/min (-L50T-M32-)



General technical data		
Type VOFD-LT-M32 ...	G1/4 basic valve and NAMUR	G1/4 basic valve and NAMUR, supply port
Valve function	3/2-way, single solenoid, closed	
Pneumatic connection	1	G1/4
	2	G1/4 and port pattern to NAMUR
	3	G1/4
	4	G1/4 and port pattern to NAMUR
Design	Directly actuated poppet valve	
Width [mm]	51	
Mounting position	Any	
Duty cycle	100%	
Sealing principle	Soft	
Manual override	None	
Reset method	Mechanical spring	
Type of actuation	Electrical	
Suitability for vacuum	Yes	
Type of control	Direct	
Flow rate for piston valve pressurisation [m ³ /h]	0.36	
Flow rate for piston valve exhausting [m ³ /h]	0.36	
Direction of flow	Non-reversible	
Product weight [g]	560	
Switching time off [ms]	9	
Switching time on [ms]	45	
Nominal width [mm]	5	
Standard nominal flow rate [l/min]	450	

Operating and environmental conditions	
Operating medium	Compressed air to ISO 8573-1:2010 [7:2:2]
Degree of protection	IP65
Operating pressure range [bar]	0 ... 10
Temperature of medium [°C]	-25 ... +60
Ambient temperature [°C]	-25 ... +60
Extended ambient temperature, Low Demand mode [°C]	-25 ... +60
Safety integrity level [SIL]	Up to SIL 3 Low Demand mode
	Up to SIL 3 High Demand mode
Corrosion resistance class CRC ¹⁾	4

1) Corrosion resistance class CRC 4 to Festo standard FN 940070
Particularly high corrosion stress. Outdoor exposure under extreme corrosive conditions. Parts exposed to aggressive media, for instance in the chemical or food industries. These applications may need to be supported by special tests (➔ also FN 940082) using appropriate media.

Materials	
Housing	Aluminium (hard Ematal-coated)
Seals	NBR
Note on materials	Contains paint-wetting impairment substances, RoHS-compliant

Basic valves VOFD-L50T-...-F10

Technical data – Basic valve NW 5 mm, G1/4 NAMUR

General technical data			
Type VOFD-L50T-M32-...		G1/4 basic valve and NAMUR	G1/4 basic valve and NAMUR, supply port
Valve function		3/2-way, single solenoid, closed	
Pneumatic connection	1	G1/4	M5 and port pattern to NAMUR
	2	Flange 1/4 and port pattern to NAMUR	Flange 1/4 and port pattern to NAMUR
	3	G1/4	G1/4
Design		Directly actuated poppet valve	
Width	[mm]	50.5	
Mounting position		Any	
Sealing principle		Soft	
Manual override		None	
Reset method		Mechanical spring	
Type of actuation		Electrical	
Suitability for vacuum		Yes	
Type of control		Direct	
Flow rate for piston valve pressurisation	[m ³ /h]	0.36	
Flow rate for piston valve exhausting	[m ³ /h]	0.36	
b value		0.25	
C value	[l/s bar]	2	
Direction of flow		Reversible	
Product weight	[g]	560	
Switching time off	[ms]	60	
Switching time on	[ms]	40	
Nominal width	[mm]	5	
Standard nominal flow rate	[l/min]	493	
Standard nominal flow rate 2→3	[l/min]	429	

Operating and environmental conditions	
Operating medium	Compressed air to ISO 8573-1:2010 [7:2:2]
Degree of protection	IP65
Operating pressure range	[bar] 0 ... 10
Temperature of medium	[°C] -25 ... +60
Ambient temperature	[°C] -25 ... +60
Extended ambient temperature,	[°C] -25 ... +60
Low Demand mode	
Safety integrity level	[SIL] Up to SIL 3 Low Demand mode
	Up to SIL 3 High Demand mode
Corrosion resistance class CRC ¹⁾	4

1) Corrosion resistance class CRC 4 to Festo standard FN 940070
Particularly high corrosion stress. Outdoor exposure under extreme corrosive conditions. Parts exposed to aggressive media, for instance in the chemical or food industries. These applications may need to be supported by special tests (→ also FN 940082) using appropriate media.

Materials	
Housing	Aluminium (Ematal coated)
Seals	NBR
Note on materials	Contains paint-wetting impairment substances, RoHS-compliant

Basic valves VOFD-L50T-...-F10

Technical data – Basic valve NW 5 mm, G1/4 NAMUR



Dimensions G1/4 basic valve and NAMUR

Download CAD data → www.festo.com

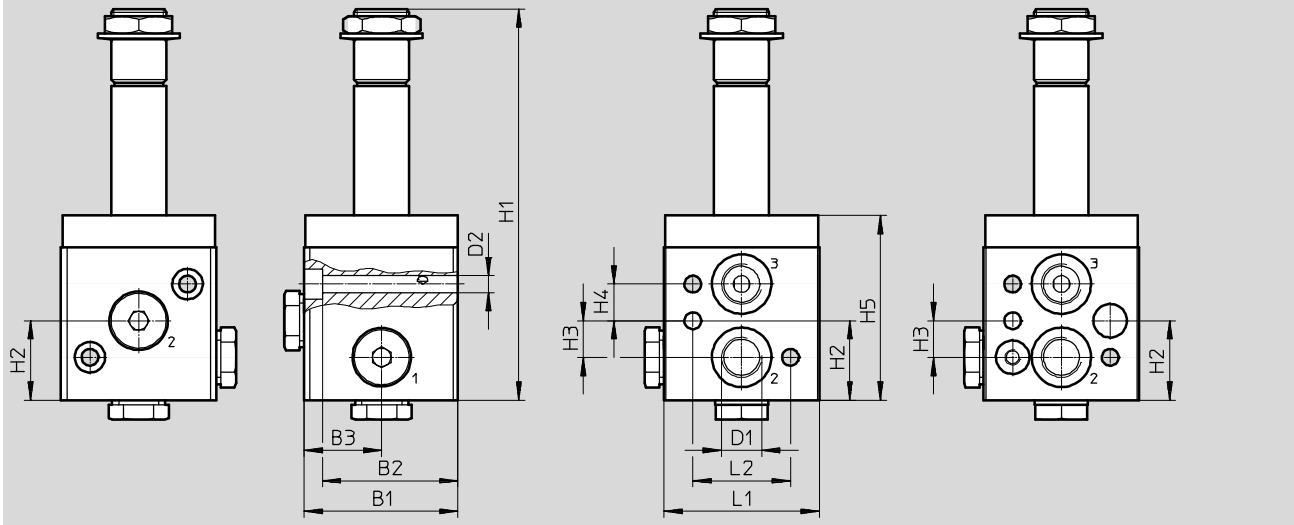

Type of flange thread	B1	B2	B3	D1	D2 ∅	H1	H2	H3	H4	H5	L1	L2
VOFD-L50T-M32-MN-FG14-F10	50.5	44.5	25.5	G1/4, NAMUR	5.5	128	26	12	12	60.5	51	32
VOFD-L50T-M32-MN-FGP14-F10												

Basic valves VOFD-L50T-...-F10

Technical data – Basic valve NW 5 mm, G1/4 NAMUR

Dimensions – G1/4 basic valve and NAMUR, supply port

Download CAD data → www.festo.com

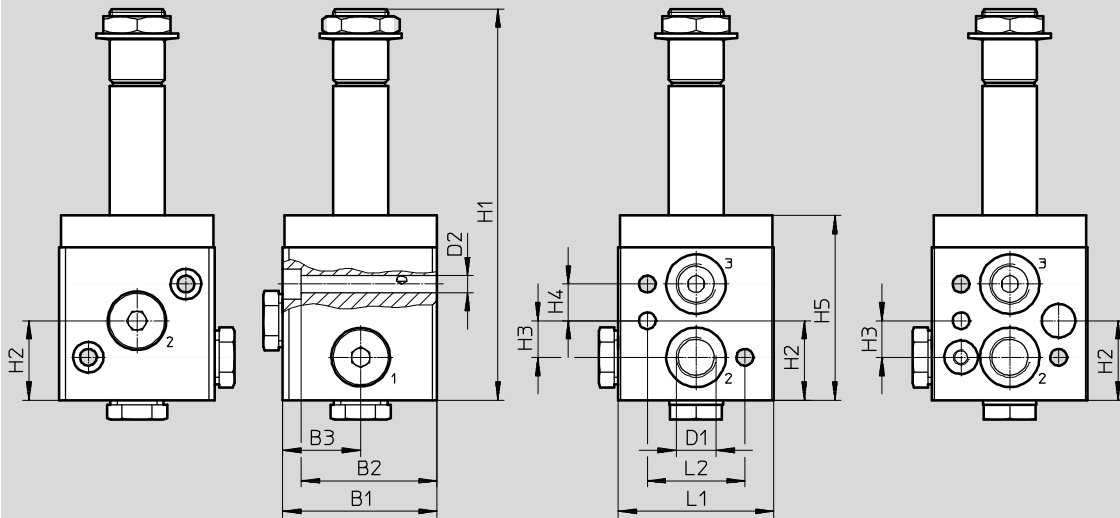

1 Coding pin M5x10

Type of flange thread	B1	B2	B3	D1	D2 Ø	H1	H2	H3	H4	H5	L1	L2
VOFD-LT-M32-MN-FGP14-F10	51	44.5	25.5	G1/4, NAMUR	5.5	128	26	12	12	60.5	51	32
VOFD-L50T-M32-MN-FGP14-10-F10												

Ordering data

Circuit symbol	Function	Pneumatic connection	Part No.	Type
Directly actuated poppet valve				
	3/2-way, single solenoid, closed	G1/4 and NAMUR	4514999	VOFD-L50T-M32-MN-FG14-10-F10
	3/2-way, single solenoid, closed	NAMUR with supply port	4515000	VOFD-L50T-M32-MN-FGP14-10-F10

Basic valves VOFD-L50T-...-F10

Technical data – Basic valve NW 5 mm, G/NPT 1/4, in-line

FESTO

Function
3/2-way valve

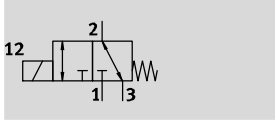

Flow rate
450 l/min (-LT-M32-)
493 l/min (-L50T-M32-)



General technical data			
Type VOFD-LT-M32 ...	G1/4 basic valve	1/4 NPT basic valve	
Valve function	3/2-way, single solenoid, closed		
Pneumatic connection	1	G1/4	1/4 NPT
	2	G1/4	1/4 NPT
	3	G1/4	1/4 NPT
Design	Directly actuated poppet valve		
Width [mm]	51		
Mounting position	Any		
Duty cycle	100%		
Sealing principle	Soft		
Manual override	None		
Reset method	Mechanical spring		
Type of actuation	Electrical		
Suitability for vacuum	Yes		
Type of control	Direct		
Flow rate for piston valve pressurisation [m³/h]	0.36		
Flow rate for piston valve exhausting [m³/h]	0.36		
Direction of flow	Reversible		
Product weight [g]	560		
Switching time off [ms]	9		
Switching time on [ms]	45		
Nominal width [mm]	5		
Standard nominal flow rate [l/min]	450		

Operating and environmental conditions	
Operating medium	Compressed air to ISO 8573-1:2010 [7:2:2]
Degree of protection	IP65
Operating pressure range [bar]	0 ... 10
Temperature of medium [°C]	-25 ... +60
Ambient temperature [°C]	-25 ... +60
Extended ambient temperature, Low Demand mode [°C]	-25 ... +60
Safety integrity level [SIL]	Up to SIL 3 Low Demand mode
	Up to SIL 3 High Demand mode
Corrosion resistance class CRC ¹⁾	4

1) Corrosion resistance class CRC 4 to Festo standard FN 940070
Particularly high corrosion stress. Outdoor exposure under extreme corrosive conditions. Parts exposed to aggressive media, for instance in the chemical or food industries. These applications may need to be supported by special tests (➔ also FN 940082) using appropriate media.

Materials	
Housing	Aluminium (hard Ematal-coated)
Seals	NBR
Note on materials	Contains paint-wetting impairment substances, RoHS-compliant

Basic valves VOFD-L50T-...-F10

Technical data – Basic valve NW 5 mm, G/NPT 1/4, in-line

General technical data			
Type VOFD-L50T-M32-...		G1/4 basic valve	1/4 NPT basic valve
Valve function		3/2-way, single solenoid, closed	
Pneumatic connection	1	G1/4	1/4 NPT
	2	G1/4	1/4 NPT
	3	G1/4	1/4 NPT
Design		Directly actuated poppet valve	
Width	[mm]	51, 28 (stainless steel design)	
Mounting position		Any	
Sealing principle		Soft	
Manual override		None	
Reset method		Mechanical spring	
Type of actuation		Electrical	
Suitability for vacuum		Yes	
Type of control		Direct	
Flow rate for piston valve pressurisation	[m ³ /h]	0.36	
Flow rate for piston valve exhausting	[m ³ /h]	0.36	
b value		0.25	
C value	[l/s bar]	2	
Direction of flow		Reversible	
Product weight	[g]	560	
Switching time off	[ms]	60	
Switching time on	[ms]	40	
Nominal width	[mm]	5	
Standard nominal flow rate	[l/min]	493	
Standard nominal flow rate 2→3	[l/min]	429	

Operating and environmental conditions	
Operating medium	Compressed air to ISO 8573-1:2010 [7:2:2]
Degree of protection	IP65
Operating pressure range	[bar] 0 ... 10
Temperature of medium	[°C] -25 ... +60
Ambient temperature	[°C] -25 ... +60
Extended ambient temperature,	[°C] -25 ... +60
Low Demand mode	
Safety integrity level	[SIL] Up to SIL 3 Low Demand mode
	Up to SIL 3 High Demand mode
Corrosion resistance class CRC ¹⁾	4

1) Corrosion resistance class CRC 4 to Festo standard FN 940070
 Particularly high corrosion stress. Outdoor exposure under extreme corrosive conditions. Parts exposed to aggressive media, for instance in the chemical or food industries. These applications may need to be supported by special tests (→ also FN 940082) using appropriate media.

Materials	
Housing	Aluminium (Ematal coated)
Stainless steel housing	High-alloy stainless steel
Seals	NBR
Note on materials	Contains paint-wetting impairment substances, RoHS-compliant

Basic valves VOFD-L50T-...-F10

Technical data – Basic valve NW 5 mm, G/NPT 1/4, in-line

Dimensions

Download CAD data → www.festo.com

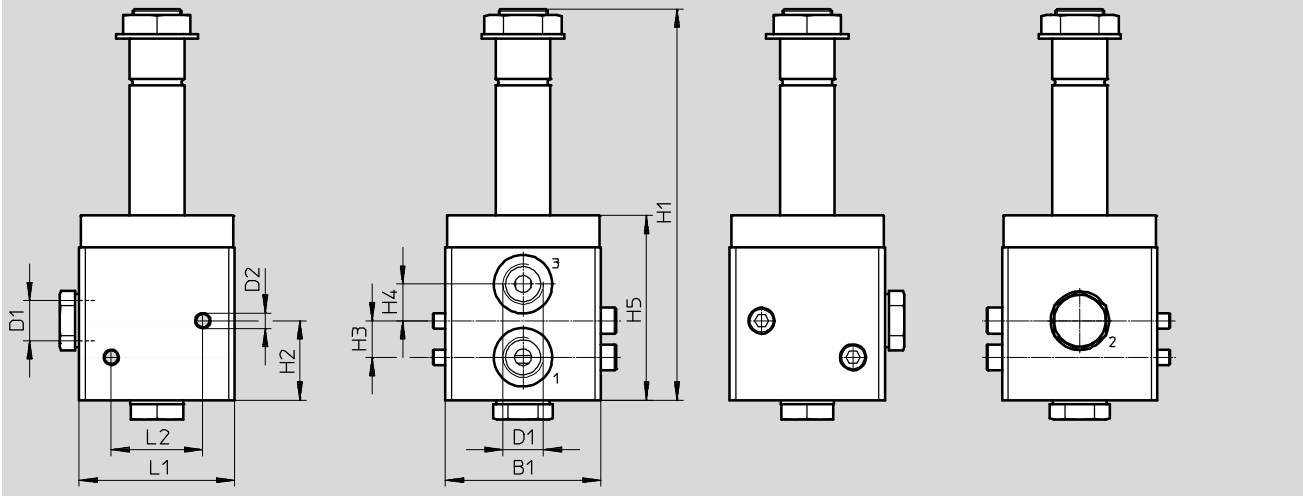

Type of G thread	B1	D1	D2 Ø	H1	H2	H3	H4	H5	L1	L2
VOFD-LT-M32-MN-G14-F10	51	G1/4	5.5	128	26	12	12	60.5	51	30
VOFD-L50T-M32-MN-G14-...-F10										

Type of NPT thread	B1	D1	D2 Ø	H1	H2	H3	H4	H5	L1	L2
VOFD-LT-M32-MN-N14-F10	51	1/4 NPT	5.5	128	26	12	12	60.5	51	30
VOFD-L50T-M32-MN-N14-...-F10										

Basic valves VOFD-L50T-...-F10

Technical data – Basic valve NW 5 mm, G/NPT 1/4, in-line

Dimensions

Download CAD data → www.festo.com

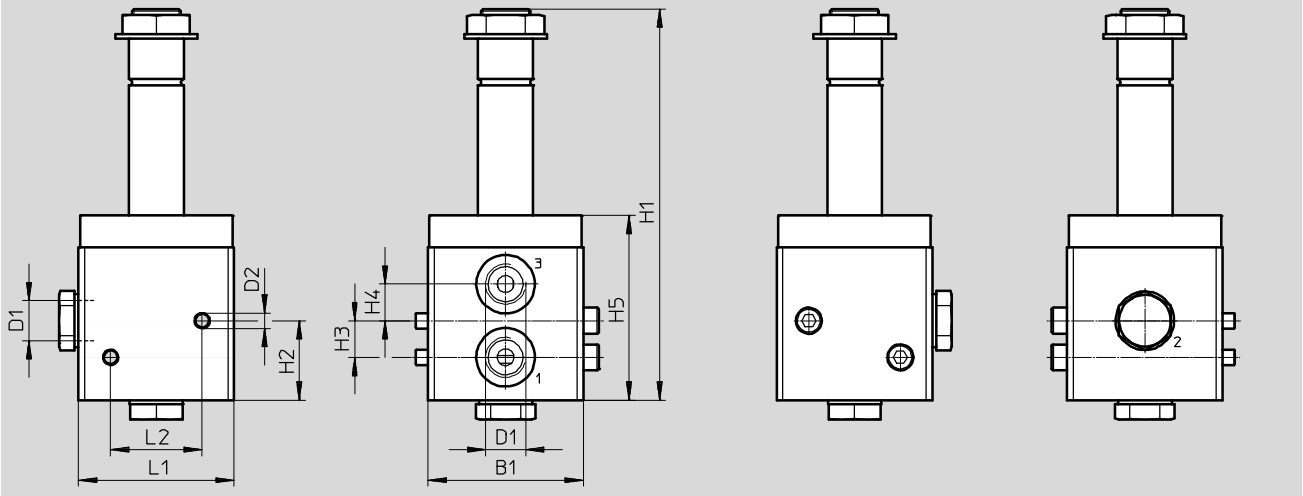

Type of G thread	B1	D1	D2 ∅	H1	H2	H3	H4	H5	L1	L2
VOFD-L50T-M32-MN-G14-...-R1-F10	28	G1/4	5.5	124	26	12	12	56	50	30

Type of NPT thread	B1	D1	D2 ∅	H1	H2	H3	H4	H5	L1	L2
VOFD-L50T-M32-MN-N14-...-R1-F10	28	1/4 NPT	5.5	124	26	12	12	56	50	30

Ordering data

Circuit symbol	Function	Pneumatic connection	Part No.	Type
Directly actuated poppet valve				
	3/2-way, single solenoid, closed	G1/4	4514997	VOFD-L50T-M32-MN-G14-10-F10
			4515019	VOFD-L50T-M32-MN-G14-10-R1-F10
		1/4 NPT	4514998	VOFD-L50T-M32-MN-N14-10-F10
			4515018	VOFD-L50T-M32-MN-N14-10-R1-F10

Basic valves VOFD-L100T-...-F10

Technical data – Modular system NW 10 mm, G/NPT 1/2, NAMUR, and in-line

FESTO

Function
3/2-way valve

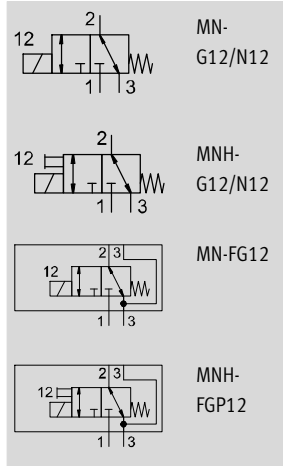

Flow rate
Up to 1900 l/min



General technical data			
Basic valve G1/2		VOFD-L100T-M32-MN-... VOFD-L100T-M32-MNH-...	
Valve function		3/2-way, single solenoid, closed	
Pneumatic connection	1	G1/2	
VOFD-...-G12	2	G1/2	
	3	G1/2	
Pneumatic connection	1	1/2 NPT	
VOFD-...-N12	2	1/2 NPT	
	3	1/2 NPT	
Pneumatic connection	1	G1/2	
VOFD-...-FG12	2	Port pattern to NAMUR, flange 1/2	
	3	G1/2	
Design		Directly actuated poppet valve	
Width	[mm]	51	
Mounting position		Any	
Sealing principle		Soft	
Manual override		None	Non-detenting
Type of reset		Mechanical spring	
Type of actuation		Electrical	
Suitability for vacuum		Yes	
Type of control		Direct	
Flow rate for piston valve pressurisation	[m ³ /h]	1.68	
Flow rate for piston valve exhausting	[m ³ /h]	1.68	
b value		0.22	
C value	[l/s bar]	7.6	
Direction of flow		Reversible	
Product weight	[g]	950	
Switching time off	[ms]	60	
Switching time on	[ms]	40	
Nominal width	[mm]	10	
Standard nominal flow rate 1 → 2	[l/min.]	1900	
Standard nominal flow rate 2 → 3	[l/min.]	1888	

Selection of solenoid coils

Suitable solenoid coils for the basic valves are available in the section on accessories.

The following solenoid coils can be selected:

- S18-70, nominal power 7 watt at 24 V DC (Ex-D)
- S18-120, nominal power 12 watt at 24 V DC (Ex-ME)

Note

Additional information and solenoid coils to fit basic valves can be found in the Festo online configurator.

➔ Internet: VACC
➔ www.festo.com/sp

Basic valves VOFD-L100T-...-F10

Technical data – Modular system NW 10 mm, G/NPT 1/2, NAMUR, and in-line

Operating and environmental conditions	
Operating medium	Compressed air to ISO 8573-1:2010 [7:-:-]
Operating pressure range [bar]	0 ... 12
Temperature of medium [°C]	-25 ... +60
Ambient temperature [°C]	-25 ... +60
Corrosion resistance class CRC ¹⁾	4

1) Corrosion resistance class CRC 4 to Festo standard FN 940070
 Particularly high corrosion stress. Outdoor exposure under extreme corrosive conditions. Parts exposed to aggressive media, for instance in the chemical or food industries. These applications may need to be supported by special tests (→ also FN 940082) using appropriate media.

Materials	
Housing	Aluminium (Ematal coated)
Seals	NBR
Note on materials	Contains paint-wetting impairment substances, RoHS-compliant

Dimensions Download CAD data → www.festo.com

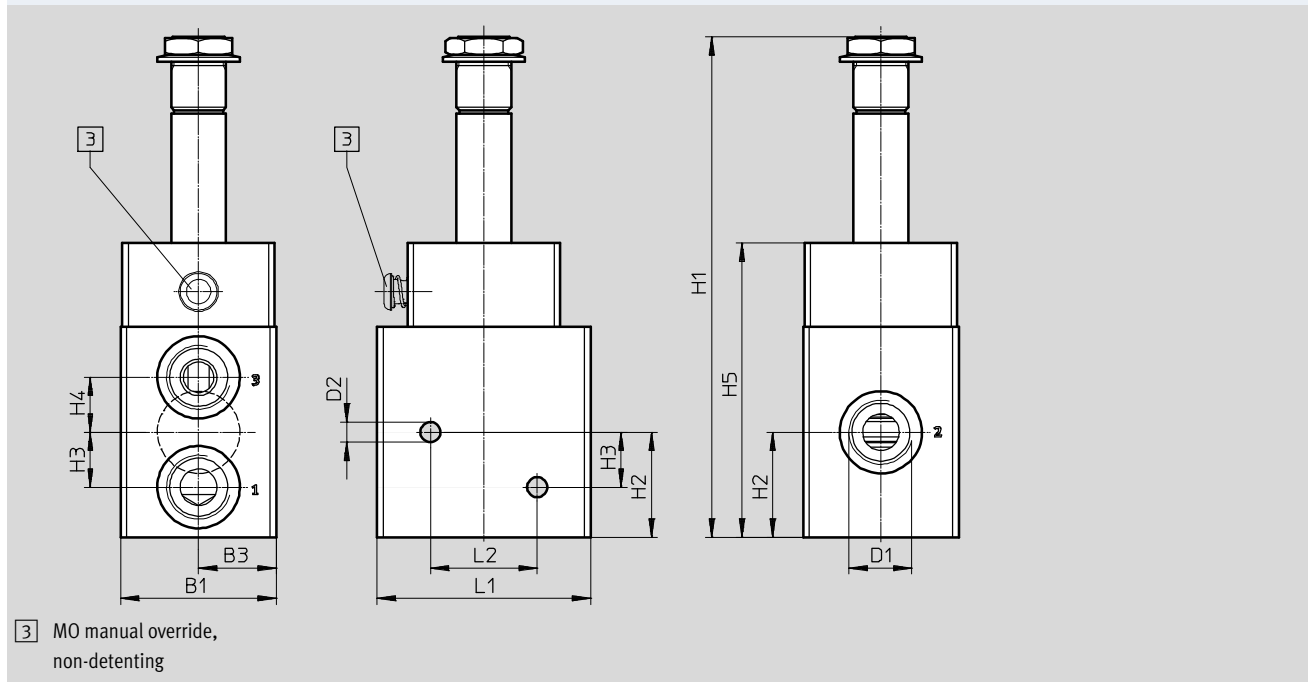

Type of G thread	B1	B3	D1	D2 Ø	H1	H2	H3	H4	H5	L1	L2
VOFD-L100T-M32-MN-G12-...-F10	51	25	G1/2	6.6	164	34.5	18	18	96.5	70	35
VOFD-L100T-M32-MNH-G12-...-F10											

Type of NPT thread	B1	B3	D1	D2 Ø	H1	H2	H3	H4	H5	L1	L2
VOFD-L100T-M32-MN-N12-...-F10	51	25	1/2 NPT	6.6	164	34.5	18	18	96.5	70	35
VOFD-L100T-M32-MNH-N12-...-F10											

Basic valves VOFD-L100T-...-F10

Technical data – Modular system NW 10 mm, G/NPT 1/2, NAMUR, and in-line

Dimensions

Download CAD data → www.festo.com

VOFD-L100T-...-FG12-...-F10

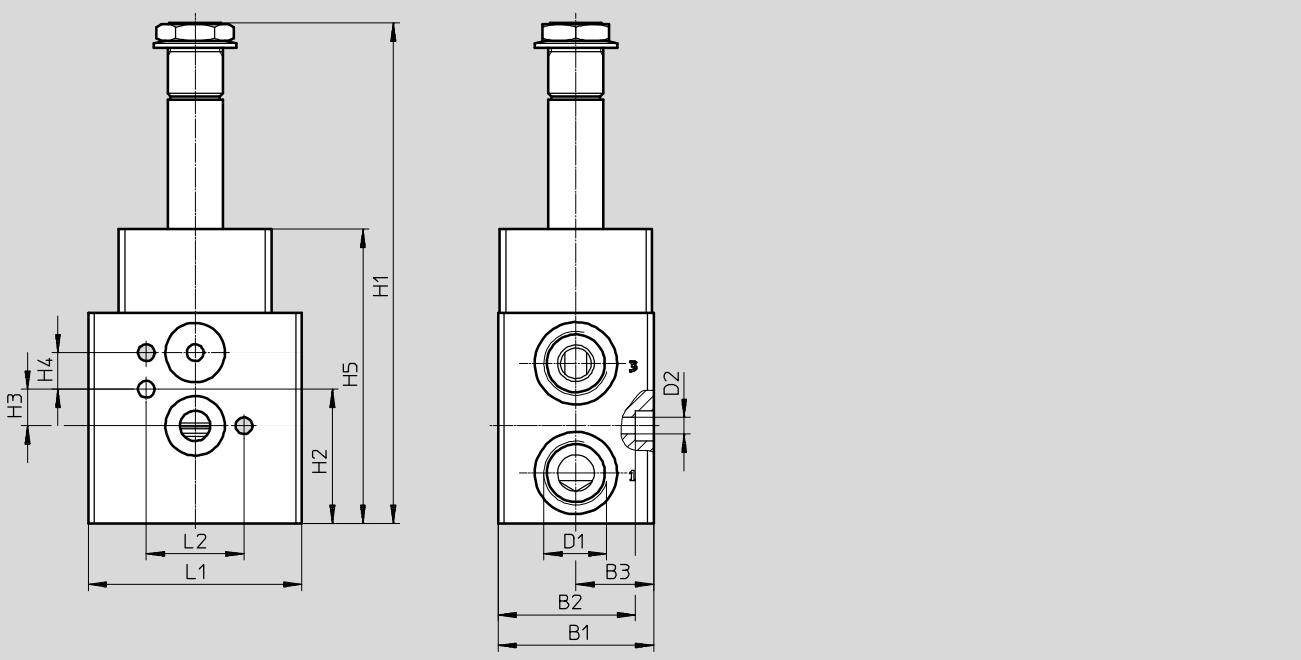



Type of flange thread	B1	B2	B3	D1	D2	H1	H2	H3	H4	H5	L1	L2
VOFD-L100T-...-FG12-...-F10	51	45	25.5	G1/2	∅ 5.5	164	44	12	12	96.5	70	32

Solenoid coils VACC

Accessories

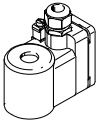
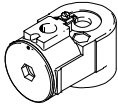
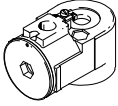
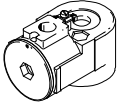

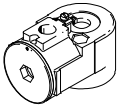
FESTO

Ordering data – Solenoid coils				
	Description		Part No.	Type
	EX4ME coil, terminal box, cable entry thread metric, M20x1.5	24 V AC/DC	562897	VACC-S18-35-K4-1U-EX4ME
		24 V AC/DC	570785	VACC-S18-35-K4-1UF-EX4ME
		110 V AC/DC	562898	VACC-S18-35-K4-2U-EX4ME
		230 V AC/DC	562899	VACC-S18-35-K4-3U-EX4ME
	EX4ME coil, terminal box, cable entry thread metric, M20x1.5	24 V AC/DC	3536527	VACC-S18-120-K4-1U-EX4ME
		24 V AC/DC	3535840	VACC-S18-120-K4-1UF-EX4ME
		48 V DC	3536573	VACC-S18-120-K4-7-EX4ME
		60 V DC	3536569	VACC-S18-120-K4-27-EX4ME
		110 V AC/DC	3536565	VACC-S18-120-K4-2U-EX4ME
		230 V AC/DC	3536568	VACC-S18-120-K4-3U-EX4ME
	EX4D coil, terminal box, cable entry thread metric, M20x1.5	24 V AC/DC	562903	VACC-S18-25-K4-1U-EX4D
		110 V AC/DC	562904	VACC-S18-25-K4-2U-EX4D
		230 V AC/DC	562905	VACC-S18-25-K4-3U-EX4D
	EX4D coil, terminal box, cable entry thread NPT, 1/2 NPT	24 V AC/DC	562900	VACC-S18-25-K5-1U-EX4D
		110 V AC/DC	562901	VACC-S18-25-K5-2U-EX4D
		230 V AC/DC	562902	VACC-S18-25-K5-3U-EX4D
	EX4D coil, terminal box, cable fitting metric, M20x1.5	230 V AC	3504741	VACC-S18-18-K4-3A-EX4D
	EX4D coil, terminal box, cable fitting NPT, 1/2 NPT	230 V AC	3546734	VACC-S18-18-K5-3A-EX4D
	EX4D coil, terminal box, cable fitting metric, M20x1.5	24 V AC/DC	3504563	VACC-S18-70-K4-1U-EX4D
		48 V AC/DC	3504574	VACC-S18-70-K4-7U-EX4D
		120 V AC/DC	3504609	VACC-S18-70-K4-16U-EX4D
		230 V AC/DC	3504639	VACC-S18-70-K4-3U-EX4D
	EX4D coil, terminal box, cable fitting NPT, 1/2 NPT	24 V AC/DC	3546549	VACC-S18-70-K5-1U-EX4D
		48 V AC/DC	3546588	VACC-S18-70-K5-7U-EX4D
		110 V AC/DC	3546625	VACC-S18-70-K5-2U-EX4D
		230 V AC/DC	3546662	VACC-S18-70-K5-3U-EX4D
	A1 coil, plug connector to EN 175301-803, type A	24 V DC	562906	VACC-S18-35-A1-1
		24 V AC	562907	VACC-S18-35-A1-1A
		110 V AC	562908	VACC-S18-35-A1-2A
		230 V AC	562909	VACC-S18-35-A1-3A
	A1 coil, plug connector to EN 175301-803, type A	24 V DC	8040580	VACC-S18-120-A1-1
		24 V AC	8040890	VACC-S18-120-A1-1A
		110 V AC	8040582	VACC-S18-120-A1-2A
		230 V AC	8040584	VACC-S18-120-A1-3A
	U2D coil, terminal box, cable entry thread 1/2 NPT	24 V DC	3546816	VACC-S18-70-K5-1-U2D
		48 V DC	3546876	VACC-S18-70-K5-7-U2D
		125 V DC	3546913	VACC-S18-70-K5-16-U2D
		220 V DC	3546949	VACC-S18-70-K5-3-U2D

Solenoid coils VACC

Accessories

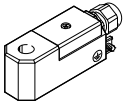
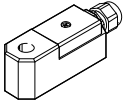

Ordering data – Solenoid coils				
	Description		Part No.	Type
	EX4ME coil, terminal box, cable entry thread metric, M20x1.5	24 V AC/DC	562893	VACC-S13-18-K4-1U-EX4ME
		24 V AC/DC	570784	VACC-S13-18-K4-1UF-EX4ME
		60 V AC/DC	8040578	VACC-S13-18-K4-27U-EX4ME
		110 V AC/DC	562894	VACC-S13-18-K4-2U-EX4ME
		230 V AC/DC	562895	VACC-S13-18-K4-3U-EX4ME
	EX4A coil, terminal box, cable entry thread metric, M20x1.5	14 ... 32 V DC	562896	VACC-S13-11-K4-1-EX4A
	A1 coil, plug connector to EN 175301-803, type A	24 V DC	562889	VACC-S13-18-A1-1
		24 V AC/DC	562890	VACC-S13-18-A1-1U
		110 V AC/DC	562891	VACC-S13-18-A1-2U
		230 V AC/DC	562892	VACC-S13-18-A1-3U

Sub-bases

Accessories – Sub-base VABS-S7-RB/BE...



Port pattern: NAMUR

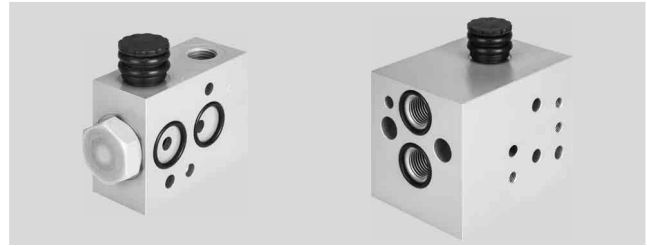

General technical data			
Type		Pressurisation and exhaust block VABS-S7-BE...	Redundancy block VABS-S7-RB...
Type of mounting		With through-hole	
Mounting position		Any	
Flow rate for piston valve pressurisation	[m ³ /h]	2.2	–
Flow rate for piston valve exhausting	[m ³ /h]	8.6	–
Product weight	[g]	250	–
Pneumatic connection	1	G1/4, 1/4 NPT	G1/4, 1/4 NPT
	2	Flange 1/4, port pattern to NAMUR	Flange 1/4, port pattern to NAMUR
	3	G1/4, 1/4 NPT	G1/4, 1/4 NPT
	12	–	G1/4, 1/4 NPT

Operating and environmental conditions		VABS-S7-BE	VABS-S7-RB
Operating medium		Compressed air to ISO 8573-1:2010 [–:–:–]	
Operating pressure	[bar]	2 ... 8	0 ... 10
Pilot air supply port		Internal	External/internal
Degree of protection		IP65	
Corrosion resistance class CRC ¹⁾		4	

1) Corrosion resistance class CRC 4 to Festo standard FN 940070
 Particularly high corrosion stress. Outdoor exposure under extreme corrosive conditions. Parts exposed to aggressive media, for instance in the chemical or food industries. These applications may need to be supported by special tests (→ also FN 940082) using appropriate media.

Materials	
Sub-base	Aluminium (Ematal coated)
Seals	NBR
Note on materials	Contains paint-wetting impairment substances, RoHS-compliant

Dimensions Download CAD data → www.festo.com

1) Socket head screw M5x35
 2) Threaded pin M5x10

Type	B1	B2	B3	B4	D1	D2	H1	H2	H3	H4	H5	H7	H8	H9	L1	L2
VABS-S7-BE-B-G14-V14-A	29	15	7	6	G1/4	M5	72.7	26	24	14	36	64	38	12	50	32
VABS-S7-BE-B-N14-V14-A					1/4 NPT											

Sub-bases

Accessories – Sub-base VABS-S7-RB/BE...



Dimensions

Download CAD data → www.festo.com

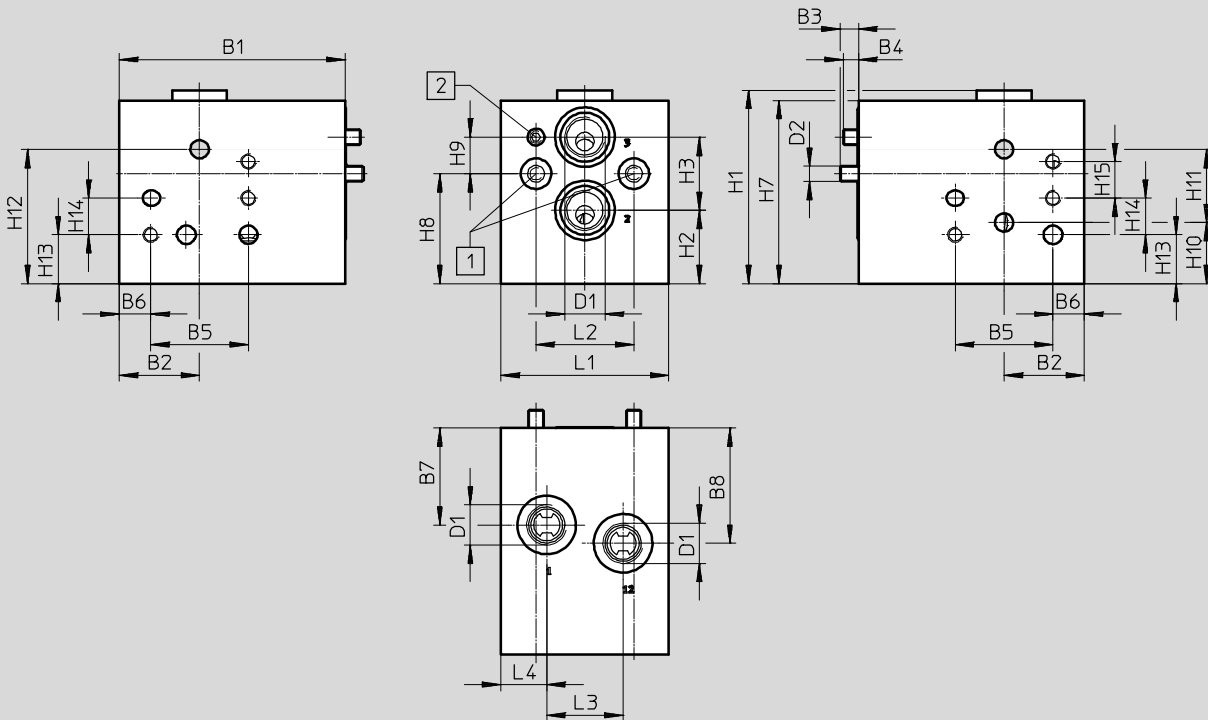

- 1 Socket head screw M5x70
- 2 Threaded pin M5x10

Type	B1	B2	B3	B4	B5	B6	B7	B8	D1	D2	L1	L2	L3	L4
VABS-S7-RB-B-G14-V14-A	74	26.3	6	5	32	103	31.7	37.7	G1/4	M5	55	32	25	15
VABS-S7-RB-B-N14-V14-A									1/4 NPT					

Type	H1	H2	H3	H7	H8	H9	H10	H11	H12	H13	H14	H15
VABS-S7-RB-B-G14-V14-A	63.4	24	24	60	36	12	20	24	44	16	12	12
VABS-S7-RB-B-N14-V14-A												

Ordering data

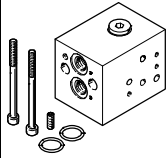
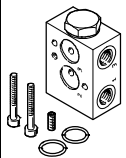
	Description	Part No.	Type
	Sub-base for mounting two solenoid valves with G-thread port for redundant circuitry, with 1/4 flange, port pattern to NAMUR. Using the additional auxiliary power terminal, the intermediate plate can also be used with pilot-controlled solenoid valves on actuators that have a positioner for fail-safe functions.	3580505	VABS-S7-RB-B-G14-V14-A
	Sub-base for mounting two solenoid valves with NPT-thread port for redundant circuitry, with 1/4 flange, port pattern to NAMUR. Using the additional auxiliary power terminal, the intermediate plate can also be used with pilot-controlled solenoid valves on actuators that have a positioner for fail-safe functions.	4727331	VABS-S7-RB-B-N14-V14-A
	Sub-base as a pressurisation and exhaust block with G-thread port, with 1/4 flange, port pattern to NAMUR.	2999476	VABS-S7-BE-B-G14-V14-A
	Sub-base as a pressurisation and exhaust block with NPT-thread port, with 1/4 flange, port pattern to NAMUR.	4727328	VABS-S7-BE-B-N14-V14-A

Mounting plates

Accessories – Mounting plate VAME-S7-P-N-...

Port pattern: NAMUR

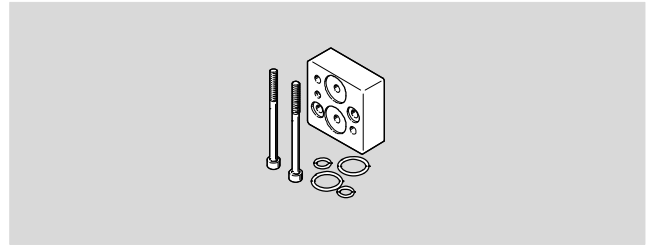

General technical data		
Type of mounting		With through-hole
Mounting position		Any
Pneumatic connection	1	M5, port pattern to NAMUR
	2	Flange 1/4, port pattern to NAMUR
	3	G1/4

Operating and environmental conditions	
Operating medium	Compressed air to ISO 8573-1:2010 [-:-:-]
Operating pressure range [bar]	0 ... 10
Operating pressure range [psi]	0 ... 145
Degree of protection	IP65 (in the installed state)
Corrosion resistance class CRC ¹⁾	4

1) Corrosion resistance class CRC 4 to Festo standard FN 940070
 Particularly high corrosion stress. Outdoor exposure under extreme corrosive conditions. Parts exposed to aggressive media, for instance in the chemical or food industries. These applications may need to be supported by special tests (→ also FN 940082) using appropriate media.

Materials	
Mounting plate	Aluminium (Ematal coated)
Seals	NBR
Note on materials	Contains paint-wetting impairment substances, RoHS-compliant

Dimensions Download CAD data → www.festo.com

Type	B1	B2	D1	H1	H2	H3	H4	L1	L2
VAME-S7-P-N-V14-A	19,5	70	M5	50	15	24	12	50	32

Ordering data			
	Description	Part No.	Type
	Mounting/spacer plate for solenoid valves when combined with ATEX solenoid coils, with 1/4 flange, port pattern to NAMUR	3581412	VAME-S7-P-N-V14-A

Solenoid valves

Accessories

FESTO

Mounting plate VAME-S7-P

Mounting plate material: Aluminium
(Ematal-coated)
Seals material: NBR
Contains paint-wetting impairment
substances, RoHS-compliant
Mounting: Via through-holes

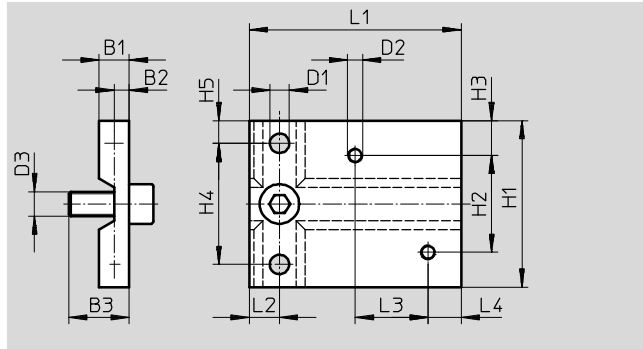

Dimensions [mm] and ordering data																Part No.	Type
B1	B2	B3	D1	D2	D3	H1	H2	H3	H4	H5	L1	L2	L3	L4	CRC ¹⁾		
10	5	20	6.4	M5	M8	55	32	11.5	40	7.5	70	10	24	11	4	563399	VAME-S7-P

1) Corrosion resistance class CRC 4 to Festo standard FN 940070
Particularly high corrosion stress. Outdoor exposure under extreme corrosive conditions. Parts exposed to aggressive media, for instance in the chemical or food industries. These applications may need to be supported by special tests (→ also FN 940082) using appropriate media.

Flow control plate for single-acting actuators

Flow control plate material:
Aluminium (Ematal-coated)
Seals material: NBR
Contains paint-wetting impairment
substances, RoHS-compliant
Operating medium: Compressed air to
ISO 8573-1:2010 [7:-:-]
Operating pressure: 0 ... 12 bar
Pilot air supply: internal/external
Mounting position: Any
Mounting: Via through-holes
Degree of protection: IP65

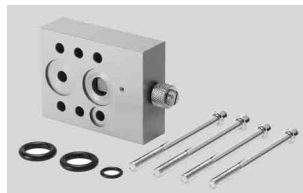

Function:
Flow control for supply air and/or
exhaust air for a drive with NAMUR
interface for valves VOFC/VOFD

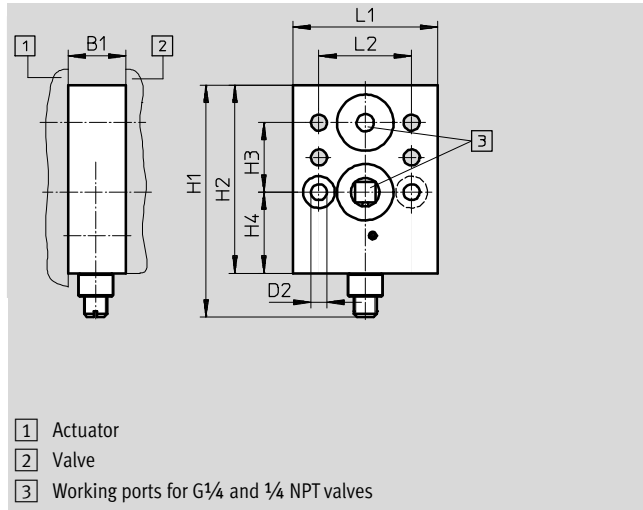

Dimensions [mm] and ordering data										Part No.	Type
B1	D2	H1	H2	H3	H4	L1	L2	CRC ¹⁾			
20	5.5	80	65	24	28	50	32	4	563401	VABF-S7-F1B5P1-F	

1) Corrosion resistance class CRC 4 to Festo standard FN 940070
Particularly high corrosion stress. Outdoor exposure under extreme corrosive conditions. Parts exposed to aggressive media, for instance in the chemical or food industries. These applications may need to be supported by special tests (→ also FN 940082) using appropriate media.

Solenoid valves

Accessories

Mounting plate

Mounting plate material: Aluminium (Ematal-coated)
 Seals material: NBR
 Contains paint-wetting impairment substances, RoHS-compliant
 Operating medium: Compressed air to ISO 8573-1:2010 [7:--:--]
 Operating pressure 0 ... 10 bar
 Mounting position: Any
 Mounting: Via through-holes
 Degree of protection: IP65

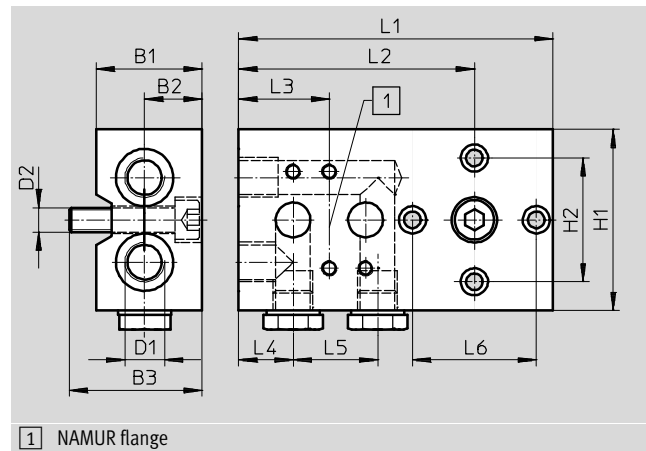

Dimensions [mm] and ordering data														Part No.	Type
B1	B2	B3	D1	D2	H1	H2	L1	L2	L3	L4	L5	L6	CRC ¹⁾	Part No.	Type
35	19	44	G $\frac{1}{4}$	M8	60	41	104	78	30	18	28	41	4	563396	VABS-S7-S-G14

1) Corrosion resistance class CRC 4 to Festo standard FN 940070
 Particularly high corrosion stress. Outdoor exposure under extreme corrosive conditions. Parts exposed to aggressive media, for instance in the chemical or food industries. These applications may need to be supported by special tests (→ also FN 940082) using appropriate media.

Mounting bracket

Mounting bracket material: Aluminium (Ematal-coated)
 Contains paint-wetting impairment substances, RoHS-compliant

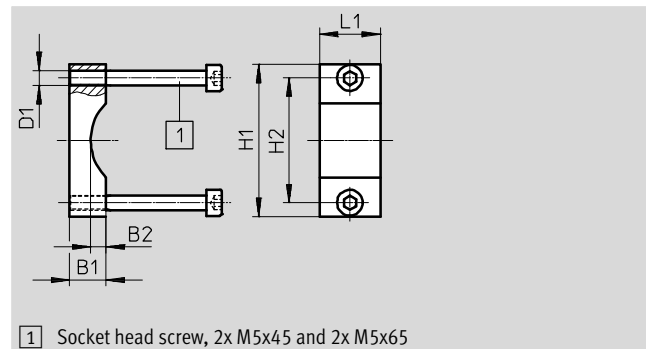

Dimensions [mm] and ordering data							Part No.	Type
B1	B2	D1	H1	H2	L1	CRC ¹⁾	Part No.	Type
12	5	M5	50	41	20	4	563403	VAME-S7-Y

1) Corrosion resistance class CRC 4 to Festo standard FN 940070
 Particularly high corrosion stress. Outdoor exposure under extreme corrosive conditions. Parts exposed to aggressive media, for instance in the chemical or food industries. These applications may need to be supported by special tests (→ also FN 940082) using appropriate media.

Solenoid valves

Accessories

FESTO

Adapter with filter

Adapter material: High-alloy stainless steel

Seals material: NBR

Note on materials:

Contains paint-wetting impairment substances, RoHS-compliant

Operating pressure: 2 ... 8 bar

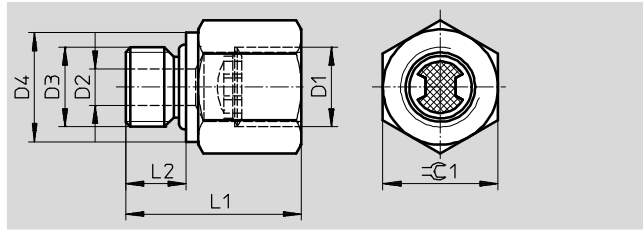

Dimensions [mm] and ordering data								Part No.	Type
D1	D2	D3	D4	L1	L2	≈C1	CRC ¹⁾		
1/4 NPT	6	G1/4	18	29	10	19	1	563397	NPFV-AF-G14-N14-MF
G1/4	6	G1/4	18	29	10	19	1	563398	NPFV-AF-G14-G14-MF
1/4 NPT	6	1/4 NPT	18	29	10	19	1	4727333	NPFV-AF-N14-N14-MF

1) Corrosion resistance class CRC 1 to Festo standard FN 940070

Low corrosion stress. For dry indoor applications or transport and storage protection. Also applies to parts behind covers, in the non-visible interior area, and parts which are covered in the application (e.g. drive trunnions).

Exhaust protection G1/4

Housing material: PA

Seals material: EPDM

Contains paint-wetting impairment substances, RoHS-compliant

Operating medium: Compressed air to ISO 8573-1:2010 [7:-:-]

Operating pressure 0 ... 10 bar

Ambient temperature: -50 ... +60 °C

Type of mounting: Screw-in, with male thread

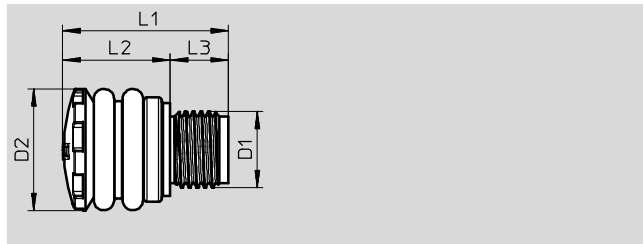

Dimensions [mm] and ordering data						Part No.	Type
D1	D2	L1	L2	L3			
G1/4, 1/4 NPT	21	28.5	18.5	10	563400	VABD-D3-SN-G14	

Exhaust protection 1/2 NPT

Housing material: PA

Seals material: EPDM

Contains paint-wetting impairment substances, RoHS-compliant

Operating medium: Compressed air to ISO 8573-1:2010 [7:-:-]

Operating pressure: 0 ... 12 bar

Ambient temperature: -50 ... +60 °C

Type of mounting: Screw-in, with male thread

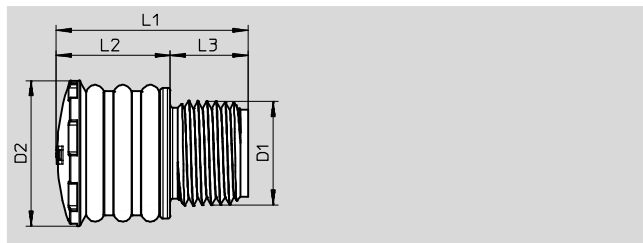

Dimensions [mm] and ordering data						Part No.	Type
D1	D2	L1	L2	L3			
G1/2, 1/2 NPT	29	38	23	15	3535104	VABD-D3-SN-N12	

Solenoid valves

Accessories



Manual override

Housing material: Anodised aluminium
 Contains paint-wetting impairment substances, RoHS-compliant
 Actuation: Manual
 Mounting position: Any

Function:
 Can be retrofitted with manual override (VOFD-50T only) in version with spring return, acting directly on the valve seat.
 The manual override can also be used only temporarily, e.g. during commissioning or inspections.

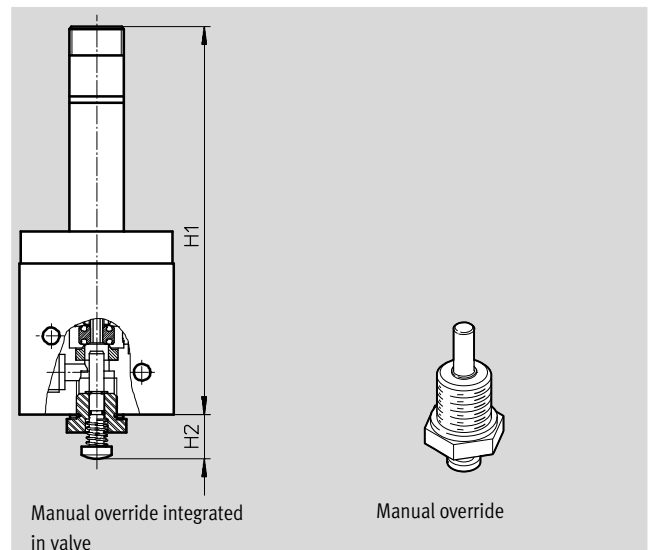

Dimensions [mm] and ordering data				
H1	H2	CRC ¹⁾	Part No.	Type
128	14	3	563402	VAOH-S8

1) Corrosion resistance class CRC 3 to Festo standard FN 940070
 High corrosion stress. Outdoor exposure under moderate corrosive conditions. External visible parts with primarily functional requirements for the surface and which are in direct contact with a normal industrial environment.

Manual override

Material: Anodised aluminium
 Contains paint-wetting impairment substances, RoHS-compliant
 Function:
 For manual override of basic valves in place of a solenoid coil.

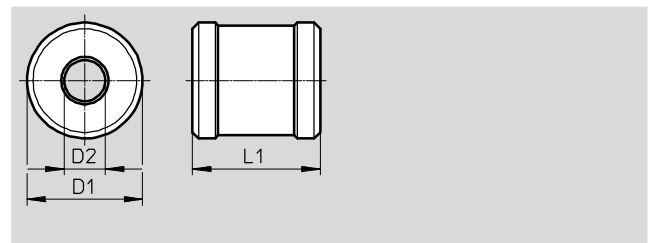

Dimensions [mm] and ordering data					
D1	D2	L1	Weight [g]	CRC ¹⁾	Part No. Type
38	13.5	42	120	2	3580654 VAOH-MB-S7-S13

1) Corrosion resistance class CRC 2 to Festo standard FN 940070
 Moderate corrosion stress. Indoor applications in which condensation may occur. External visible parts with primarily decorative requirements for the surface and which are in direct contact with the ambient atmosphere typical for industrial applications.

Ordering data				
Description			Part No.	Type
Connecting cable Technical data → Internet: kmc				
	Operating voltage 24 V DC, switching status indication with LED	Cable length 2.5 m	30931	KMC-1-24 DC-2,5-LED
		Cable length 5 m	30933	KMC-1-24 DC-5-LED
		Cable length 10 m	193459	KMC-1-24-10-LED
	Operating voltage up to 240 V AC	Cable length 2.5 m	30932	KMC-1-230 AC-2,5
		Cable length 5 m	30934	KMC-1-230 AC-5
Plug socket Technical data → Internet: mssd				
	Cable connection using clamping screws		34583	MSSD-C

Festo - Your Partner in Automation



1 Festo Inc.
5300 Explorer Drive
Mississauga, ON L4W 5G4
Canada

Festo Customer Interaction Center
Tel: 1 877 463 3786
Fax: 1 877 393 3786
Email: customer.service.ca@festo.com

2 Festo Pneumatic
Av. Ceylán 3,
Col. Tequesquináhuac
54020 Tlalnepantla,
Estado de México

Multinational Contact Center
01 800 337 8669
ventas.mexico@festo.com

3 Festo Corporation
1377 Motor Parkway
Suite 310
Islandia, NY 11749

Festo Customer Interaction Center
1 800 993 3786
1 800 963 3786
customer.service.us@festo.com

4 Regional Service Center
7777 Columbia Road
Mason, OH 45040

Connect with us



www.festo.com/socialmedia



www.festo.com

Subject to change