

Planar surface gantries EXCM



Planar surface gantries EXCM

Features



At a glance

General remarks

- A gantry that is characterised by high functionality in compact installation spaces
- The drive concept provides a low moving mass.
- Perfectly matching drive and controller package
- The kinematics are actuated via 2 stepper motors with integrated optical encoder (closed loop) and one matching two-axis controller
- Can be actuated using two operating modes:
 - Direct mode via Ethernet and CAN
 - Record selection via digital I/O, Ethernet and CAN
- Permits flexible motor mounting

Sample applications

- Feeding, pressing, joining components
- Dispensing liquid media
- Mounting electronic components

EXCM-30

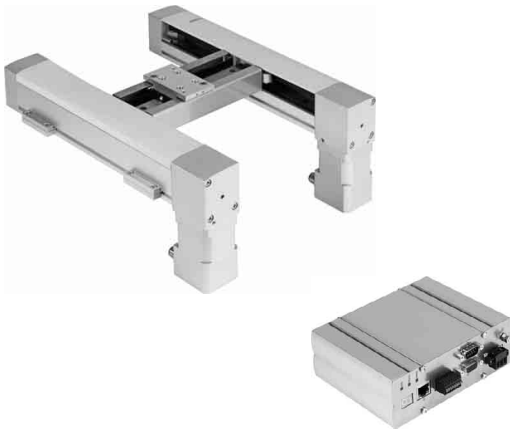

EXCM-40

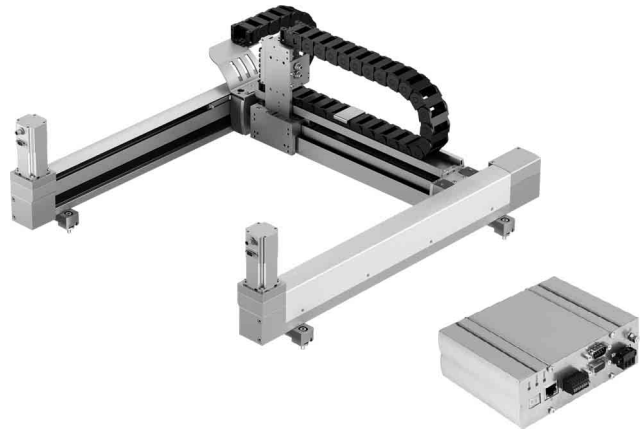

Operating principle

A slide is moved in a two-dimensional space (X-axis/Y-axis) via a toothed belt. The system is powered via 2 fixed motors in position-controlled

operation (closed loop). The motors are coupled to the toothed belt. The belt is guided via guide pulleys so that

the slide can move to any position in a working space when the motors are actuated accordingly.

		Motor 1		
		+	•	-
Motor 2	+	→	↘	↓
	•	↗	•	↖
	-	↑	↗	←

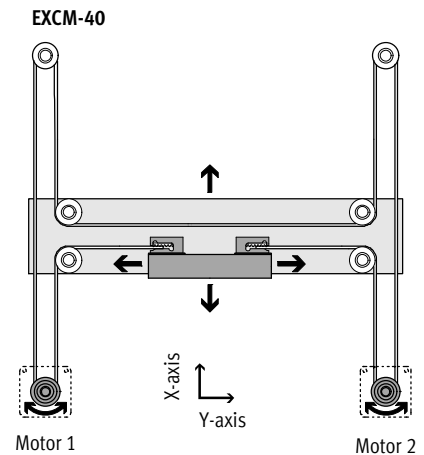
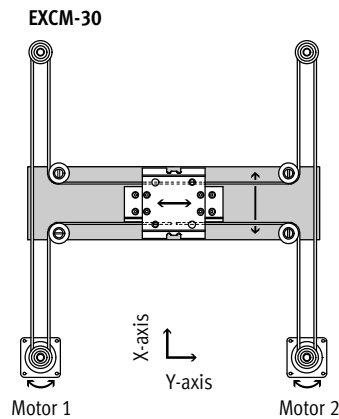

Planar surface gantries EXCM

Key features

Planar surface gantry			
Type		EXCM-30	EXCM-40
Guide		Recirculating ball bearing guide	Recirculating ball bearing guide
Stroke of the			
X-axis	[mm]	100, 150, 200, 300, 400, 500	–
		90 ... 700	200 ... 2000
Y-axis	[mm]	110, 160, 210, 260, 310, 360, 410, 460, 510	–
		110 ... 510	200 ... 1000
Rated load for max. dynamic response ¹⁾	[kg]	2/3 ²⁾	4
Repetition accuracy	[mm]	±0.05	±0.1
Mounting position		Any	Horizontal
Controller		Separate	Separate
Further technical data		→ page 6	→ page 22

- 1) Rated load = tool load (attachment components) + payload
- 2) Vertical/horizontal mounting position

Controller			
For planar surface gantry		EXCM-30	EXCM-40
Can be ordered through modular product system EXCM-...-E			
Load voltage	[V DC]	24	–
Nominal current	[A]	6	–
Switching logic		NPN	–
Configuration support		FCT (Festo Configuration Tool) with plug-in EXCM	–
Technical data		→ page 41	–
Can be ordered through modular product system EXCM-...-PF			
Load voltage	[V DC]	48 or 24	48
Nominal current	[A]	10	–
Switching logic		PNP	–
Safety function to EN 61800-5-2		Safe torque off (STO)	–
Configuration support		FCT (Festo Configuration Tool) with plug-in CMXH	–
Technical data		→ Internet: cmxh	–

FCT software – Festo Configuration Tool

Software platform for electric drives from Festo

Record table

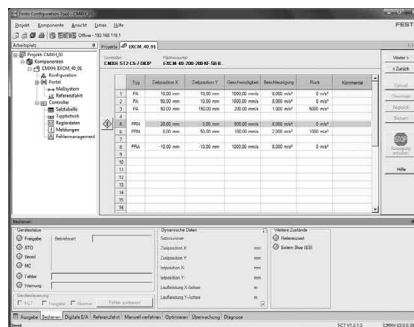
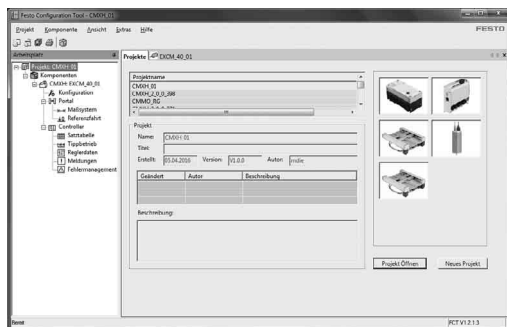

- All drives in a system can be managed and saved in a common project
- Project and data management for all supported type of equipment
- Easy to use thanks to graphically supported parameter entry
- Universal mode of operation for all drives
- Work offline at your desk or online at the machine
- 31 records ensure flexible positioning
- The following parameters can be set flexibly for each application:
 - Position
 - Speed
 - Acceleration
 - Return (only with controller CMXH)
- Absolute or relative positioning values can be used
- Complete performance test

Planar surface gantries EXCM

Key features

FESTO

EXCM-30 – Motor mounting variants

Further technical data → page 6

Underneath

EXCM-30-...-B1 – Cable outlet at front

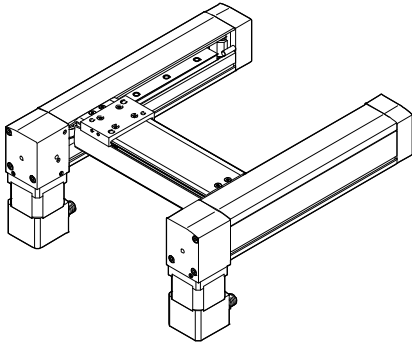

EXCM-30-...-B2 – Cable outlet at rear

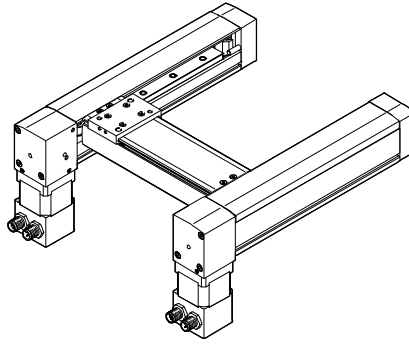

EXCM-30-...-B3 – Cable outlet inside

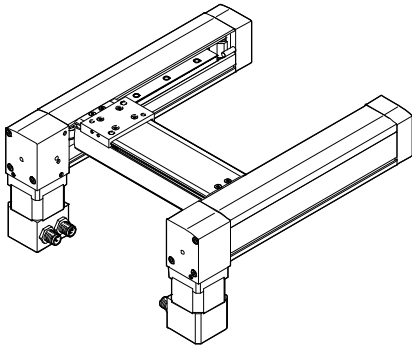

EXCM-30-...-B4 – Cable outlet outside

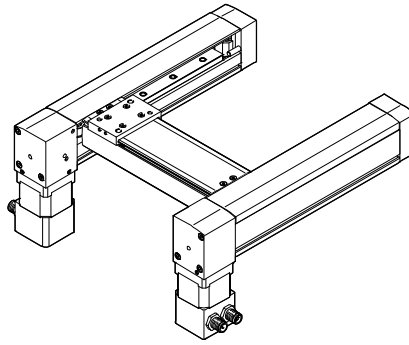

Top

EXCM-30-...-T1 – Cable outlet at front

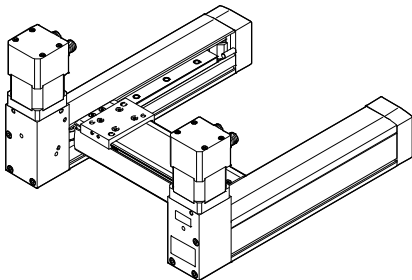

EXCM-30-...-T2 – Cable outlet at rear

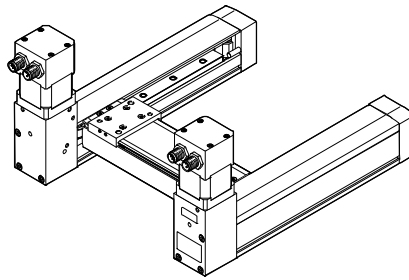

EXCM-30-...-T3 – Cable outlet inside

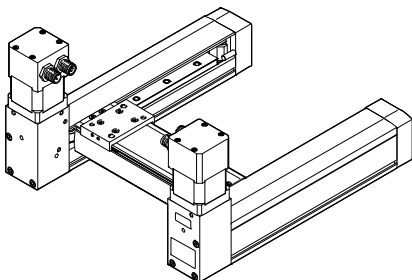

EXCM-30-...-T4 – Cable outlet outside

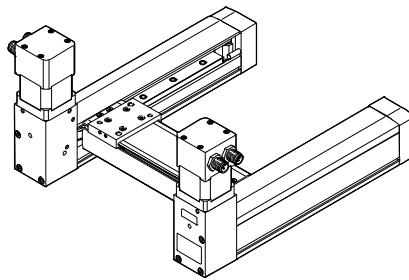

Planar surface gantries EXCM

Key features

FESTO

EXCM-40 – Motor mounting variants

Further technical data → page 22

EXCM-40-...-B – Motor underneath

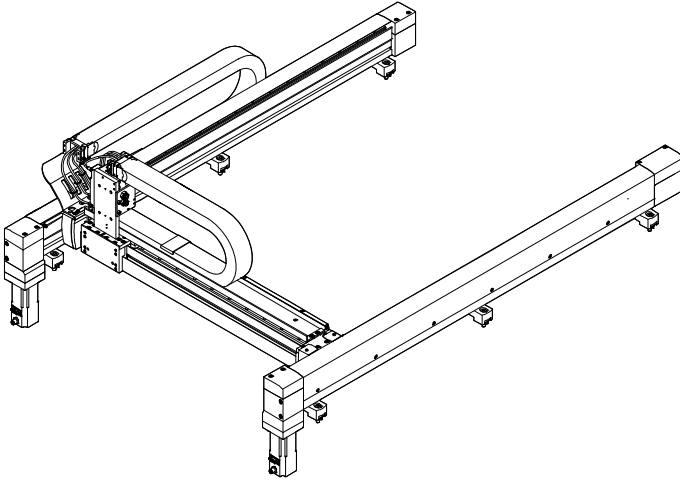

EXCM-40-...-T – Motor on top

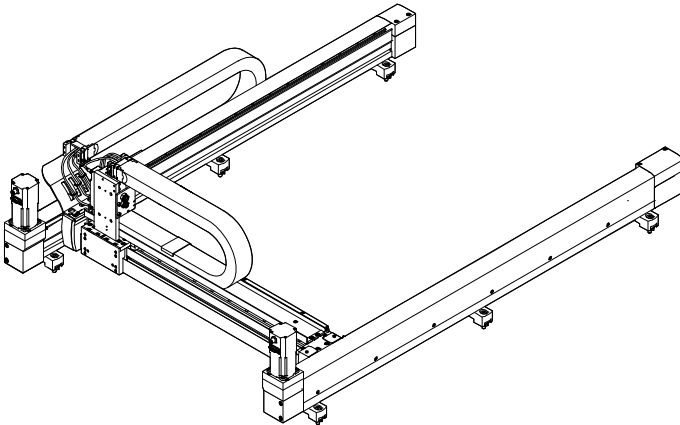

Planar surface gantries EXCM-30

Type codes

EXCM – 30 – 300 – 210 – KF – ST – – B1

Type

EXCM	Planar surface gantry
------	-----------------------

Size

Stroke of the X-axis [mm]

Stroke of the Y-axis [mm]

Guide

KF	Recirculating ball bearing guide
----	----------------------------------

Motor type

ST	Stepper motors
SB	Stepper motors with brake
W	Without stepper motors

Protection against particles

–	Standard
P8	Protected version

Motor attachment position

B	Underneath
B1	Underneath, cable outlets to the front
B2	Underneath, cable outlets to the rear
B3	Underneath, cable outlets inwards
B4	Underneath, cable outlets outwards
T	Top
T1	On top, cable outlets to the front
T2	On top, cable outlets to the rear
T3	On top, cable outlets inwards
T4	On top, cable outlets outwards

Planar surface gantries EXCM-30

Type code

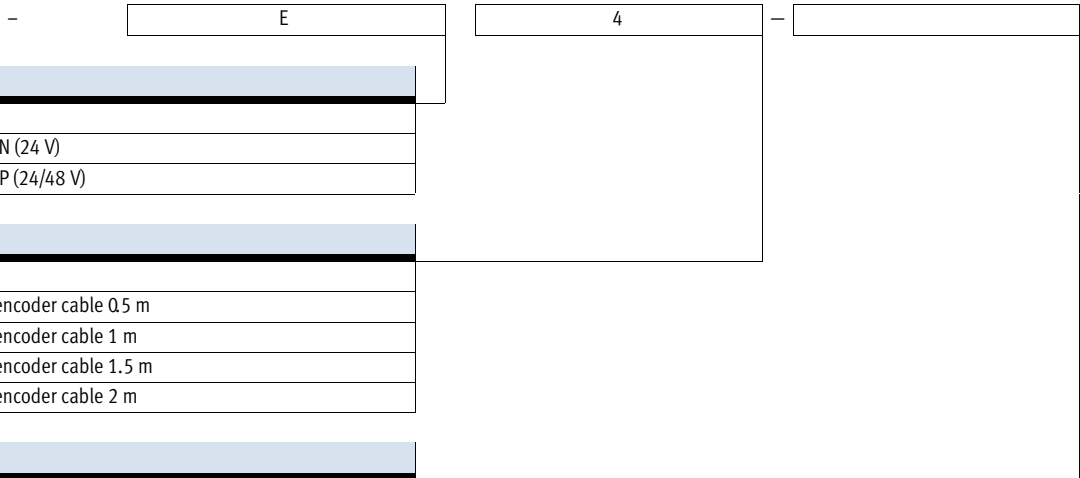

Controller	
-	Without
E	Remote, NPN (24 V)
PF	Remote, PNP (24/48 V)

Line length	
-	Without
2	Motor and encoder cable 0.5 m
3	Motor and encoder cable 1 m
4	Motor and encoder cable 1.5 m
5	Motor and encoder cable 2 m

Document language	
DE	German
EN	English
ES	Spanish
FR	French
IT	Italian
RU	Russian
ZH	Chinese

 Note
 Ordering data → page 20

Planar surface gantries EXCM-30

Peripherals overview

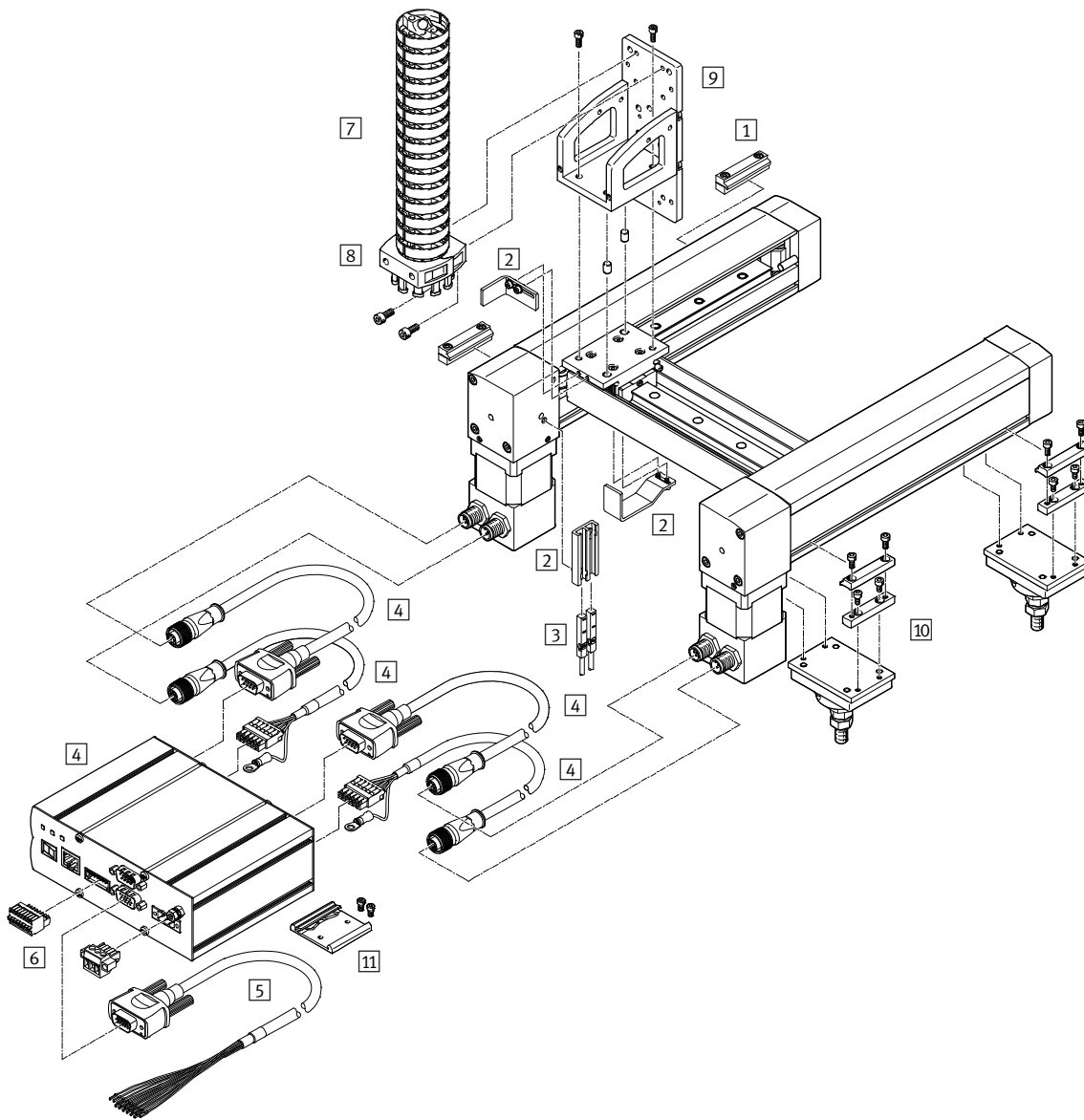

Variants and accessories

1 With protection against particles EXCM-...-P8

The cover protects the guide of the Y-axis against contamination.

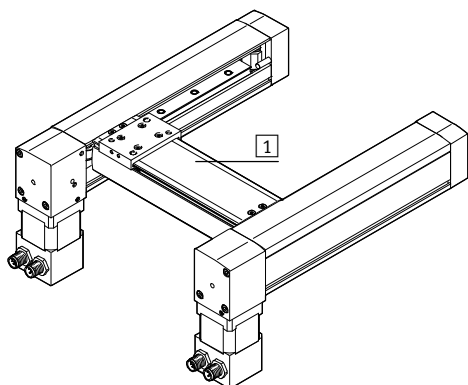

2 With adjusting kit EADC-E11

With the adjusting kit, the gantry can be aligned after installation.

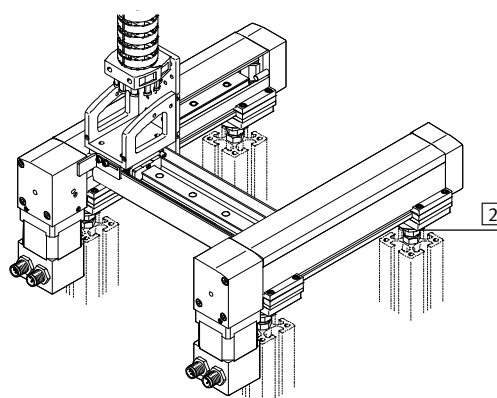

Planar surface gantries EXCM-30

Peripherals overview

Accessories		
Type	Description	→ Page/Internet
1 Profile mounting MUE	Included in the scope of delivery of the planar surface gantry: • X-stroke < 500 mm: 2 pairs • X-stroke ≥ 500 mm: 3 pairs	44
2 Sensor mounting EAPR	For homing in combination with third-party motors	46
3 Proximity sensor SIES-8M		50
4 Drive package comprising controller, motor, motor cable	Available with or without drive package	20
5 Control cable NEBC-S1H15	For the I/O interface to any controller	51
6 Plug connector	Included in the scope of delivery of the drive package	-
7 Energy chain EADH-U-3D	For the cable routing of the Z-axis	47
8 Connection set	Holder for mounting the energy chain Included in the scope of delivery: • 2 connectors • 4 socket head screws M4x10	47
9 Mounting kit EAHT-E9	Mounting kit for the energy chain and a Z-axis, like EGSL, DGSL, EGSK Stroke reduction in combination with mounting kit EAHT → page 15	45
10 Adjusting kit EADC-E11	Height-adjustable mounting kit	44
11 H-rail mounting CAFM-D3	For mounting the controller to an H-rail to EN 50022	43

 Note

Homing is always carried out using the mechanical stop in combination with the drive package from Festo; the sensor mounting and proximity sensor are not required in this case.

Planar surface gantries EXCM-30

Technical data

FESTO

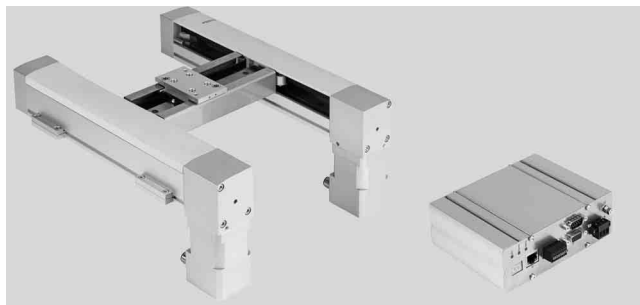

General technical data		
Design	Planar surface gantry	
Guide	Recirculating ball bearing guide	
Stroke of the		
X-axis	[mm]	100, 150, 200, 300, 400, 500 90 ... 700
Y-axis	[mm]	110, 160, 210, 260, 310, 360, 410, 460, 510 110 ... 510
Rated load for max. dynamic response ¹⁾	[kg]	2/3 ²⁾
Max. process force ³⁾	[N]	100
Max. torque	→ page 12	
Max. no-load torque	→ page 12	
Nominal torque of motor	[Nm]	0.5
Motor holding torque	[Nm]	0.5
Max. acceleration		
EXCM-...-E	[m/s ²]	10
EXCM-...-PF	[m/s ²]	20/10 ⁴⁾
Max. speed		
EXCM-...-E	[m/s]	0.5
EXCM-...-SB-...-PF	[m/s]	0.5
EXCM-...-ST-...-PF	[m/s]	1.0/0.5 ⁴⁾
Repeat accuracy	[mm]	±0.05
Mounting position	Any ⁵⁾	
Type of mounting		
Planar surface gantry	With profile mounting	
Controller	Via H-rail, on base plate	

- 1) Rated load = tool load (attachment components) + payload
- 2) Vertical/horizontal mounting position. Applies to EXCM-...-E with stroke of the Y-axis of 360 mm → page 11
- 3) Perpendicular to working plane, at standstill
- 4) In case of a load supply of 48 V/24 V
- 5) Motors with brake must be used in the case of vertical installation

Operating and environmental conditions		
Degree of protection	IP20	
Ambient temperature	[°C]	+10 ... +45
Storage temperature	[°C]	-10 ... +60
Relative humidity	[%]	0 ... 90 (non-condensing)
Noise level	[dB(A)]	52
Duty cycle	[%]	100
CE marking (see declaration of conformity)	To EU Machinery Directive	

Planar surface gantries EXCM-30

Technical data

Materials

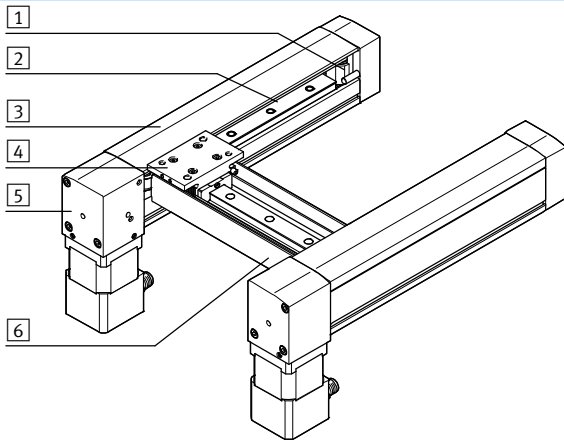

Size	30	
1	Guide pulley	Aluminium
2	Toothed belt	Polychloroprene with glass cord
3	Cover	
	X-axis	Polymer
	Y-axis	Stainless steel
4	Slides	Aluminium
5	End cap	Aluminium
6	Y-traverse	Aluminium
-	Guide	Steel
	Ball bearings	Steel
	Note on materials	RoHS compliant
		Contains paint-wetting impairment substances

Weight [kg]

Product weight with 0 mm stroke (without rated load, motors and controllers)

EXCM-...	1.73
EXCM-...-P8	1.80
Y-axis (without slide)	0.34/0.4 ¹⁾

Additional weight per 50 mm stroke

X-axis	0.237
Y-axis	0.120/0.132 ¹⁾

Weight

2 motors	0.9
2 motors with brake	1.5
Controller	0.65

1) Standard/with protection against particles P8

Acceleration a as a function of the payload m and stroke of the Y-axis

The following data applies to a horizontal mounting position and refers to the service life of the mechanical system of 3500 km. For vertical installation positions, please get in touch with your local contact at Festo.

The centre of gravity of the slide is at the height of the slide in the Z-direction and in the centre of the slide in the X-/Y-directions.

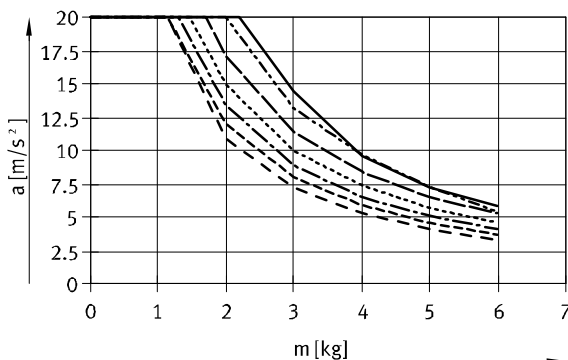

- Stroke, Y-axis = 110/160/210 mm
- Stroke, Y-axis = 260 mm
- Stroke, Y-axis = 310 mm
- Stroke, Y-axis = 360 mm
- Stroke, Y-axis = 410 mm
- Stroke, Y-axis = 460 mm
- Stroke, Y-axis = 510 mm

Planar surface gantries EXCM-30

Technical data



Torque M as a function of rotational speed n

Typical motor characteristic curve with nominal voltage and optimal controller.

In combination with:

EXCM-...-ST-...-E or EXCM-...-ST-...-PF (at 24 V)

EXCM-...-SB-...-PF (at 48 V)

In combination with:

EXCM-...-ST-...-PF (at 48 V)

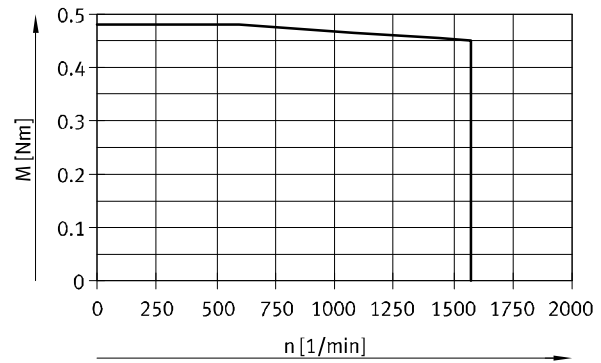
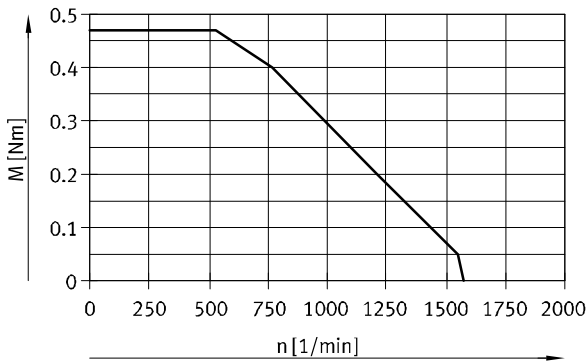

No-load torque M as a function of speed n

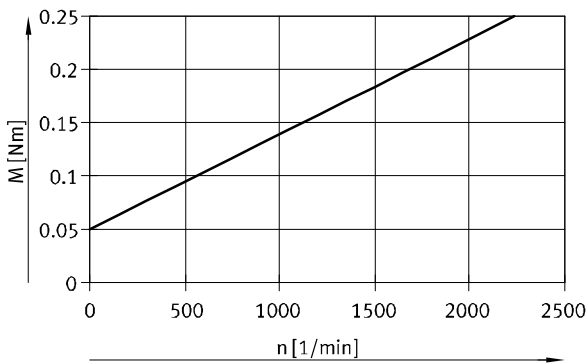

Characteristic load values

The centre of gravity of the slide is at the height of the slide in the Z-direction and in the centre of the slide in the X-/Y-directions.

The system is subject to the greatest load in the case of 45° travel.

The following data apply in this case:

Formula for calculating the required torque M and the required rotational speed n

$$M_{45^\circ} = a \times (4.28 \times m_L + 2.14 \times m_{Ay} + 23.38 \times J_m + 0.56) \times 10^{-3} + M_R$$

$$n_{45^\circ} = 2232 \times v$$

a = acceleration [m/s²]

v = speed [m/s]

m_{Ay} = product weight of the Y-axis [kg]

→ page 11

m_L = attachment component (Z-axis) [kg]

with payload

J_m = moment of inertia of motor [kgcm²]

→ table below

M_R = no-load torque [Nm]

→ page 12

n_{45°} = rotational speed at 45° travel [rpm]

Combination of planar surface gantry with stepper motor for X-/Y-axis

Planar surface gantry	Motor	Moment of inertia of the motor [kgcm ²]
EXCM-30-...-ST	EMMS-ST-42-...	0.082
EXCM-30-...-SB	EMMS-ST-42-...	0.095

Planar surface gantries EXCM-30

Technical data

Sample calculation

Given:

Planar surface gantry
EXCM-30-700-410-KF-ST-...-E

$$a_{\max} = 10 \text{ m/s}^2$$

$$v_{\max} = 0.35 \text{ m/s}$$

$$\text{Payload} = 2 \text{ kg}$$

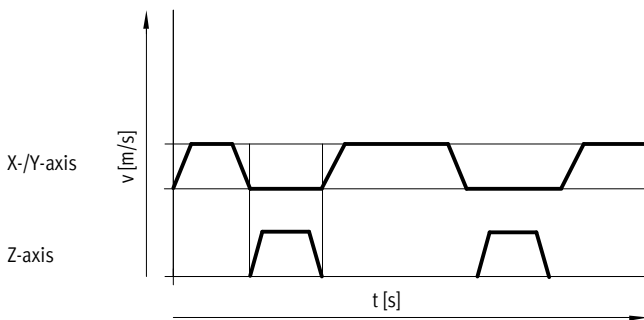

Calculation:

1. What is the max. acceleration permitted by the mechanical system?

Moving mass m_L at the Y-axis:

$$m_L = 2 \text{ kg}$$

Stroke of the Y-axis:

410 mm

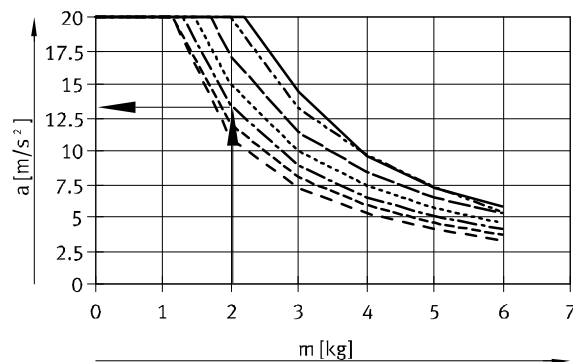

- Stroke, Y-axis = 110/160/210 mm
- - - - Stroke, Y-axis = 260 mm
- - - - Stroke, Y-axis = 310 mm
- - - - Stroke, Y-axis = 360 mm
- - - - Stroke, Y-axis = 410 mm
- - - - Stroke, Y-axis = 460 mm
- - - - Stroke, Y-axis = 510 mm

Result:

In case of a moving mass m_L of 2 kg the maximum permissible acceleration is 13 m/s^2 .

The required acceleration of 10 m/s^2 is therefore permissible.

Note

The following information applies to a horizontal mounting position. For vertical installation positions, please get in touch with your local contact at Festo.

The centre of gravity of the slide is at the height of the slide in the Z-direction and in the centre of the slide in the X-/Y-directions.

Planar surface gantries EXCM-30

Technical data

Sample calculation

2. Is the attached motor sufficient for this load?

Given:

$$a_{\max} = 10 \text{ m/s}^2 \quad M_{45^\circ} = a \times (4.28 \times m_L + 2.14 \times m_{Ay} + 23.38 \times J_m + 0.56) \times 10^{-3} + M_R$$

$$v_{\max} = 0.35 \text{ m/s} \quad n_{45^\circ} = 2232 \times v$$

$$m_{Ay} = 1.32 \text{ kg}$$

$$m_L = 2 \text{ kg}$$

$$J_m = 0.082 \text{ kgcm}^2$$

a = acceleration [m/s²]

v = speed [m/s]

m_{Ay} = product weight of the Y-axis [kg]

→ page 11

m_L = payload

J_m = moment of inertia of motor [kgcm²]

→ page 12

M_R = no-load torque [Nm]

→ page 12

n_{45°} = rotational speed at 45° travel [rpm]



Note

These requirements for the dynamic response apply to 45° travel. For travel only in the X- or Y-direction, the dynamic values may be higher.

Determination of M_R:

$$n_{45^\circ} = 2232 \times 0,35 \text{ m/s} = 781,2 \text{ 1/min}$$

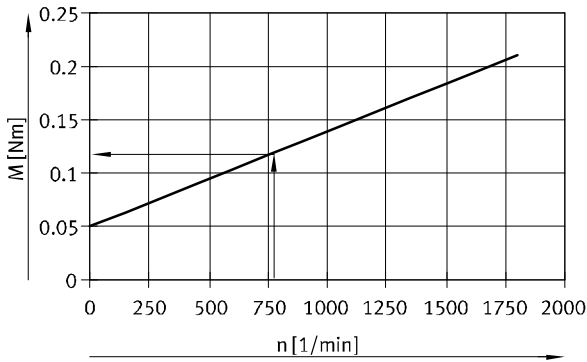

No-load torque:
 EXCM-30

$$M_R = 0.12 \text{ Nm}$$

$$M_{45^\circ} = a \times (4.28 \times m_L + 2.14 \times m_{Ay} + 23.38 \times J_m + 0.56) \times 10^{-3} + M_R$$

$$M_{45^\circ} = 10 \frac{\text{m}}{\text{s}^2} \times (4.28 \times 2 \text{ kg} + 2.14 \times 1.32 \text{ kg} + 23.38 \times 0.082 \text{ kgcm}^2 + 0.56) \times 10^{-3} + 0.12 \text{ Nm} = 0.26 \text{ Nm}$$

Result:

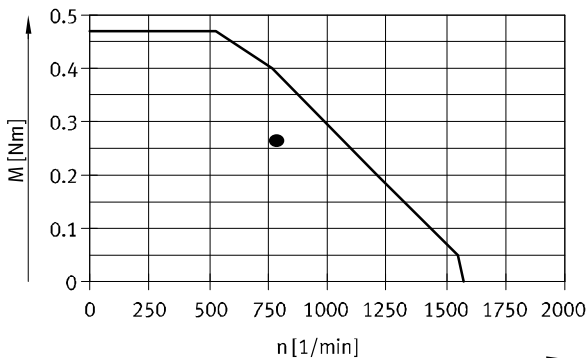

The value for the torque lies below the motor characteristic curve. The design is thus acceptable.

Planar surface gantries EXCM-30

Technical data

Minimum number of profile mountings

Different numbers of profile mountings must be used as a function of the mounting position and stroke of the X-axis.

Horizontal mounting position
Stroke < 500 mm

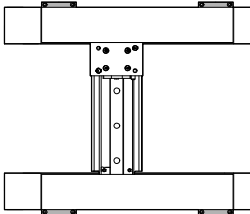

Stroke ≥ 500 mm

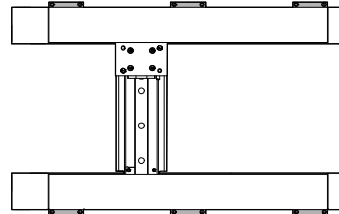

Vertical mounting position
Stroke < 500 mm

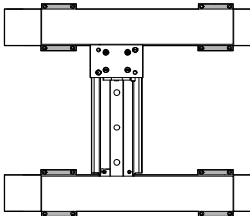

Stroke ≥ 500 mm

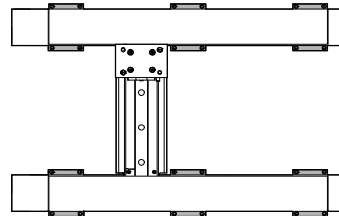

Stroke of the X-axis [mm]	Number of profile mountings	Vertical mounting position
	Horizontal mounting position	
100 ... 499	2 per profile, inside or outside	4 per profile, inside and outside
500 ... 700	3 per profile, inside or outside	6 per profile, inside and outside

Stroke reduction in combination with mounting kit EAHT-E9

The reduction is influenced by the following factors:

- 1 The mounting kit EAHT-E9 is wider than the slide of the Y-axis.
- 2 Through the adjusting kit EADC-E11 or profile mounting MUE mounted on the inside of the X-axis
- 3 Through an additional mounting surface for the cover in combination with EXCM-...-P8 (with protection against particles)

EXCM-...

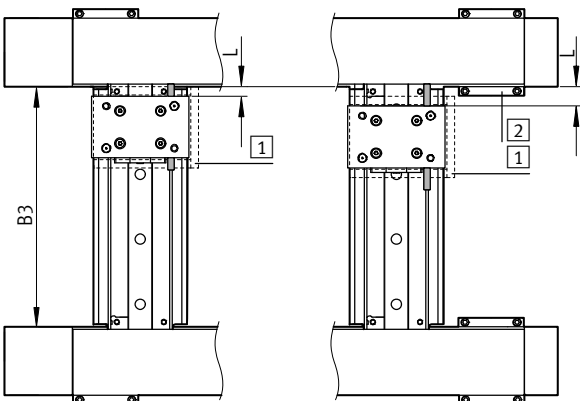

EXCM-...-P8

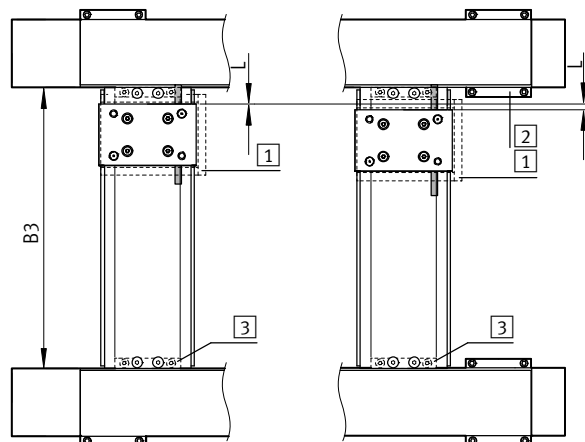

	B3 (→ as of page 16)		L	
	For EXCM-...	For EXCM-...-P8	For EXCM-...	For EXCM-...-P8
With mounting kit EAHT-E9	38 + stroke	63 + stroke	2x 8 mm	No stroke reduction
With mounting kit EAHT-E9 and adjusting kits EADC-E11/profile mounting MUE			2x 16 mm	2x 4 mm

Planar surface gantries EXCM-30

Technical data

FESTO

Dimensions

Download CAD data → www.festo.com

EXCM-30-... and EXCM-30-...-P8

Motor attachment position – Underneath

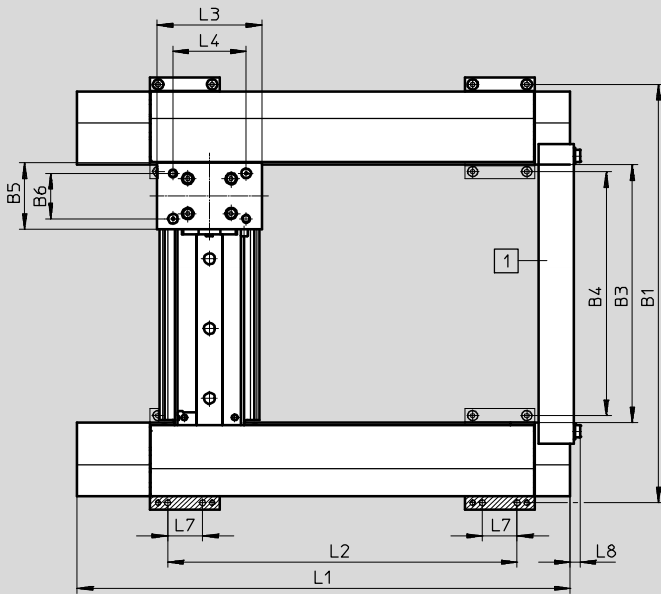

- 1 Transport lock serves as transport aid and can be removed after assembly
- 2 Threaded pin for securing the adjusting screws
- 3 Screw for setting the toothed belt tension

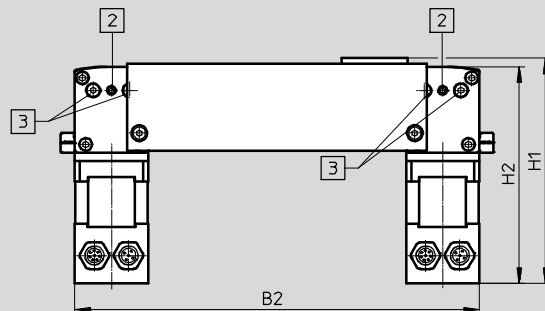
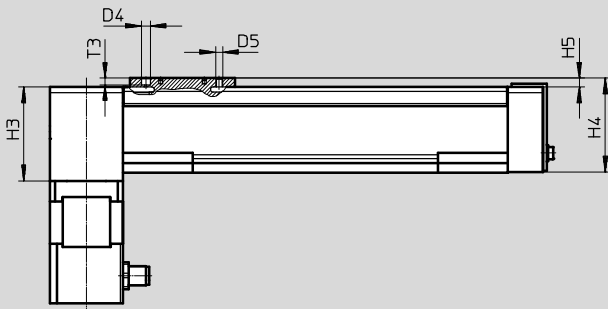

Motor interface

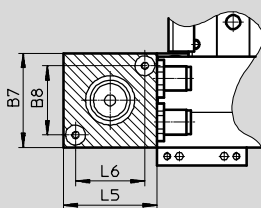

Coupling interface with radial threaded pins

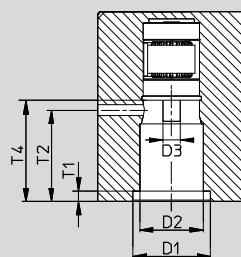

Coupling interface with tangential clamping screws

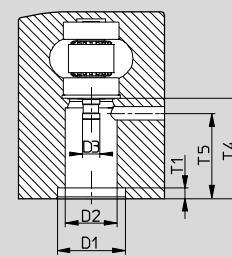

Planar surface gantries EXCM-30

Technical data

Type	B5	B6 ±0.03	B7	B8 ±0.1	D1 ∅ H7	D2 ∅	D3 ∅ F8	D4 ∅ H8	D5
EXCM-30-...	38	26	42	31	22	16	5	5	M4
EXCM-30-...-P8	38	26	42	31	22	16	5	5	M4

Type	H1		H2		H3	H4	H5	L3	L4 ±0.03
	EXCM-...-ST	EXCM-...-SB	EXCM-...-ST ±0.7	EXCM-...-SB					
EXCM-30-...	129.2	186.2	124.2	181.2	53.8	54	5	60	42
EXCM-30-...-P8	131.2	188.2	124.2	181.2	53.8	56	7	60	42

Type	L5	L6 ±0.1	L7	L8	T1	T2	T3	T4	T5
EXCM-30-...	42	31	20	5.6	3	26	3.7	28.7	24.5
EXCM-30-...-P8	42	31	20	5.6	3	26	3.7	28.7	24.5

Stroke-dependent dimensions

Stroke of the X-axis	L1	L2 ±0.2
	100	233
150	283	200.5
200	333	250.5
300	433	350.5
400	533	450.5
500	633	550.5
90 ... 700	133 + stroke	50.5 + stroke

Stroke of the Y-axis	B1		B2		B3		B4	
	EXCM-30-...-		EXCM-30-...-		EXCM-30-...-		EXCM-30-...-	
		P8		P8		P8		P8
110	240	265	232	257	148	173	140	165
160	290	315	282	307	198	223	190	215
210	340	365	332	357	248	273	240	265
260	390	415	382	407	298	323	290	315
310	440	465	432	457	348	373	340	365
360	490	515	482	507	398	423	390	415
410	540	565	532	557	448	473	440	465
460	590	615	582	607	498	523	490	515
510	640	665	632	657	548	573	540	565
110 ... 510	130 + stroke	155 + stroke	122 + stroke	147 + stroke	38 + stroke	63 + stroke	30 + stroke	55 + stroke

Planar surface gantries EXCM-30

Technical data



Dimensions

Download CAD data → www.festo.com

EXCM-30-... and EXCM-30-...-P8

Motor attachment position – On top

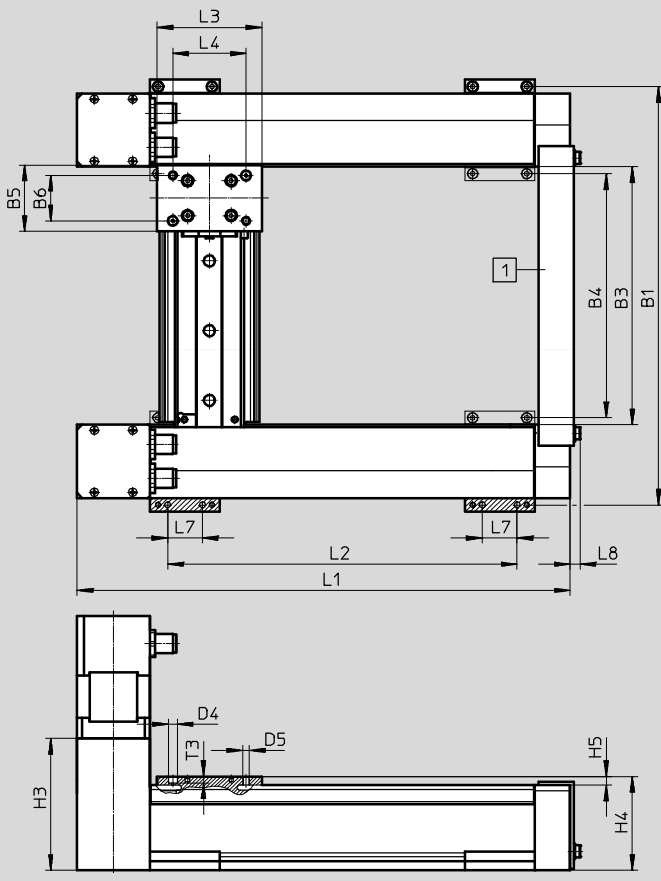

- 1 Transport lock serves as transport aid and can be removed after assembly
- 2 Threaded pin for securing the adjusting screws
- 3 Screw for setting the toothed belt tension

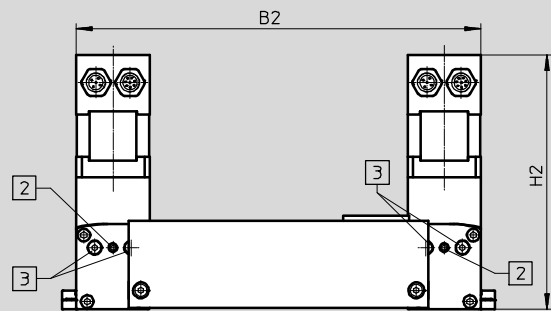

Motor interface

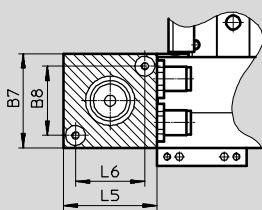

Coupling interface with radial threaded pins

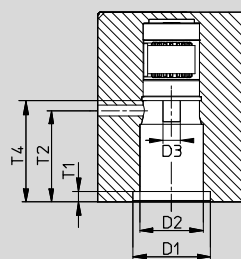

Coupling interface with tangential clamping screws

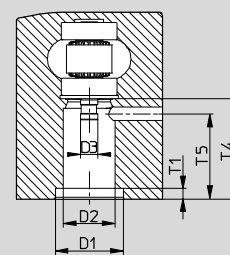

Planar surface gantries EXCM-30

Technical data

Type	B5	B6 ±0.03	B7	B8 ±0.1	D1 ∅ H7	D2 ∅	D3 ∅ F8	D4 ∅ H8
EXCM-30-...	38	26	42	31	22	16	5	5
EXCM-30-...-P8	38	26	42	31	22	16	5	5

Type	D5	H2		H3	H4	H5	L3	L4 ±0.03
		EXCM-...-ST ±1	EXCM-...-SB					
EXCM-30-...	M4	146.2	203.2	75.6	54	5	60	42
EXCM-30-...-P8	M4	146.2	203.2	75.6	56	7	60	42

Type	L5	L6 ±0.1	L7	L8	T1	T2	T3	T4	T5
EXCM-30-...	42	31	20	5.6	3	26	3.7	28.7	24.5
EXCM-30-...-P8	42	31	20	5.6	3	26	3.7	28.7	24.5

Stroke-dependent dimensions

Stroke of the X-axis	L1	L2 ±0.2
100	233	150.5
150	283	200.5
200	333	250.5
300	433	350.5
400	533	450.5
500	633	550.5
90 ... 700	133 + stroke	50.5 + stroke

Stroke of the Y-axis	B1		B2		B3		B4	
	EXCM-30-...-		EXCM-30-...-		EXCM-30-...-		EXCM-30-...-	
		P8		P8		P8		P8
110	240	265	232	257	148	173	140	165
160	290	315	282	307	198	223	190	215
210	340	365	332	357	248	273	240	265
260	390	415	382	407	298	323	290	315
310	440	465	432	457	348	373	340	365
360	490	515	482	507	398	423	390	415
410	540	565	532	557	448	473	440	465
460	590	615	582	607	498	523	490	515
510	640	665	632	657	548	573	540	565
110 ... 510	130 + stroke	155 + stroke	122 + stroke	147 + stroke	38 + stroke	63 + stroke	30 + stroke	55 + stroke

Planar surface gantries EXCM-30

Ordering data – Modular product system

Ordering table				
Size	30	Condi- tions	Code	Entry code
M Module no.	2226101			
Product type	EXCM series M		EXCM	EXCM
Size	30		-30	30
Stroke of the X-axis	[mm] 100		-100	
	[mm] 150		-150	
	[mm] 200		-200	
	[mm] 300		-300	
	[mm] 400		-400	
	[mm] 500		-500	
	[mm] 90 ... 700		-...	
Stroke of the Y-axis	[mm] 110		-110	
	[mm] 160		-160	
	[mm] 210		-210	
	[mm] 260		-260	
	[mm] 310		-310	
	[mm] 360		-360	
	[mm] 410		-410	
	[mm] 460		-460	
	[mm] 510		-510	
	[mm] 110 ... 510		-...	
Guide	Recirculating ball bearing guide		-KF	KF
Motor type	Stepper motors		-ST	
	Stepper motors with brake		-SB	
	Without stepper motors	1	-W	
Protection against particles	Standard			
	Protected version		-P8	
Motor attachment position	Underneath	2	-B	
	Underneath, cable outlets to the front		-B1	
	Underneath, cable outlets to the rear		-B2	
	Underneath, cable outlets inwards		-B3	
	Underneath, cable outlets outside		-B4	
	Top	2	-T	
	On top, cable outlets to the front		-T1	
	On top, cable outlets to the rear		-T2	
	On top, cable outlets inwards		-T3	
On top, cable outlets outside		-T4		

- 1** **W** In combination with "Without stepper motors" W, controllers E and PF are not required
- 2** **B, T** Not in combination with stepper motors ST and SB. Option if third-party motors are mounted

M Mandatory data
O Options

Transfer order code

Planar surface gantries EXCM-30

Ordering data – Modular product system



Ordering table				
Size	30	Condi- tions	Code	Entry code
O Controller	Without			
	Remote, NPN (24 V)		-E	
	Remote, PNP (24/48 V)		-PF	
Cable length	Without			
	Motor and encoder cable 0.5 m		2	
	Motor and encoder cable 1 m		3	
	Motor and encoder cable 1.5 m		4	
	Motor and encoder cable 2 m		5	
M Document language	German		-DE	
	English		-EN	
	Spanish		-ES	
	French		-FR	
	Italian		-IT	
	Russian		-RU	
	Chinese		-ZH	

M Mandatory data

O Options

Transfer order code

- - -

Planar surface gantries EXCM-40

Type codes

		EXCM	-	40	-	600	-	400	-	KF	-	SB	-	B	-	PF	-	7	
Type																			
EXCM	Planar surface gantry																		
Size																			
Stroke of the X-axis [mm]																			
Stroke of the Y-axis [mm]																			
Guide																			
KF	Recirculating ball bearing guide																		
Motor type																			
SB	Stepper motor with brake																		
ST	Stepper motor																		
W	Without motor																		
Motor attachment position																			
B	Underneath																		
T	Top																		
Controller																			
-	Without																		
PF	Remote, PNP (48 V)																		
Cable length																			
-	Without																		
6	5 m																		
7	10 m																		

Planar surface gantries EXCM-40

Type codes

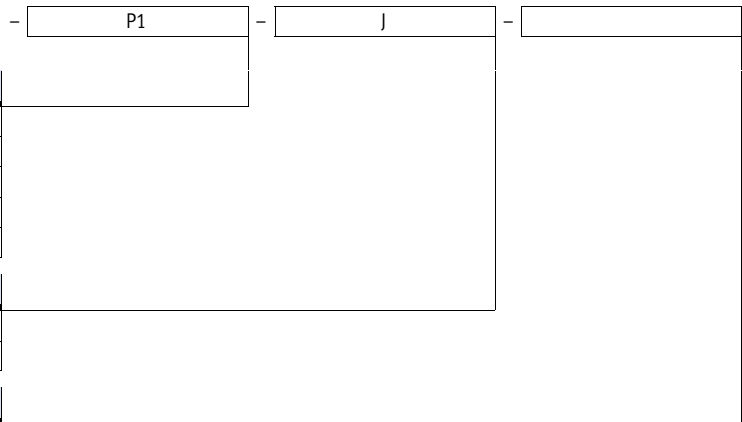

Attachment components

-	Without
HE1	Electric lifting unit, 100 mm stroke
P1	Pneumatic lifting unit, 50 mm stroke
P2	Pneumatic lifting unit, 100 mm stroke
P3	Pneumatic lifting unit, 150 mm stroke

Mounting kit

-	With mounting component
J	With adjusting kit

Document language

DE	German
EN	English
ES	Spanish
FR	French
IT	Italian
RU	Russian
ZH	Chinese

-  Note
 Ordering data → page 40

Planar surface gantries EXCM-40

Key features



Selection of attachment components

The following variants for the Z-axis can optionally be ordered using the modular product system → page 40:

- Without attachment component
- With pneumatic attachment component (mini slide DGSL)
- With electric attachment component (mini slide EGSL)

The drives are fully connected on delivery. Cables and tubes are routed as far as the output of the energy chain (X-axis).

EXCM-... (without attachment component)

The following are pre-installed:

- 2 supply ports for e.g. Z-axis
- Multi-pin plug distributor for bundling signals:
 - E.g. proximity sensor

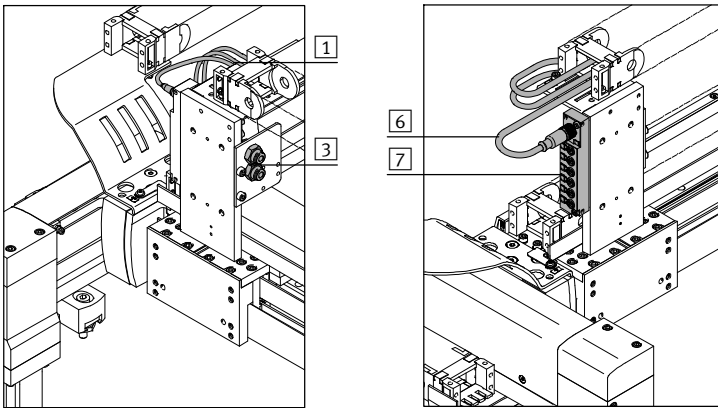

Components	Number of components
1 Tubing	2
3 Bulkhead fitting	2
6 Plug socket with cable	1
7 Multi-pin plug distributor (6-way)	1
– Earthing cable	2

EXCM- ... -P... (pneumatic attachment component)

The following are pre-installed:

- Solenoid valve for controlling the drive
- 1 supply port for e.g. gripper
- Proximity sensor for end position sensing
- Multi-pin plug distributor for bundling signals:
 - For mini slide DGSL:
 - 2 proximity sensors
 - 1 solenoid valve
 - 3 ports are available

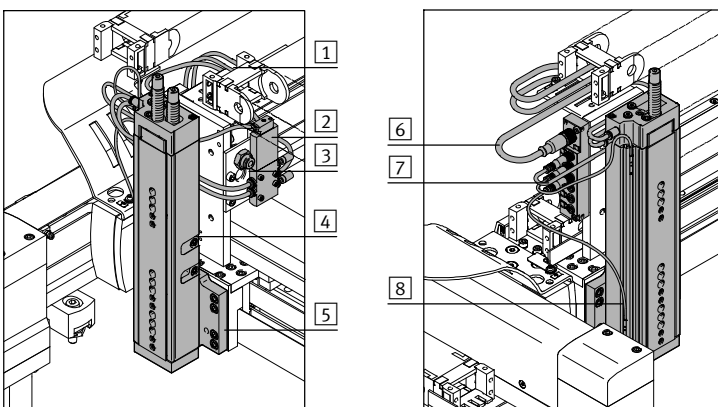

Components	Number of components
1 Tubing	2
2 Solenoid valve	1
3 Bulkhead fitting	1
4 Mini slide DGSL-...-Y3A ¹	1
5 Adapter plate	1
6 Plug socket with cable	1
7 Multi-pin plug distributor (6-way)	1
8 Proximity sensor	2
– Earthing cable	2

1) For EXCM-40, the mini slide DGSL-16 is used with progressive shock absorbers. Further information → Internet: dgs1

Planar surface gantries EXCM-40

Key features

Selection of attachment components

EXCM-...-HE1 (electric attachment component)

The following are pre-installed:

- 2 supply ports for e.g. gripper
- Multi-pin plug distributor for bundling signals:
 - E.g. proximity sensor

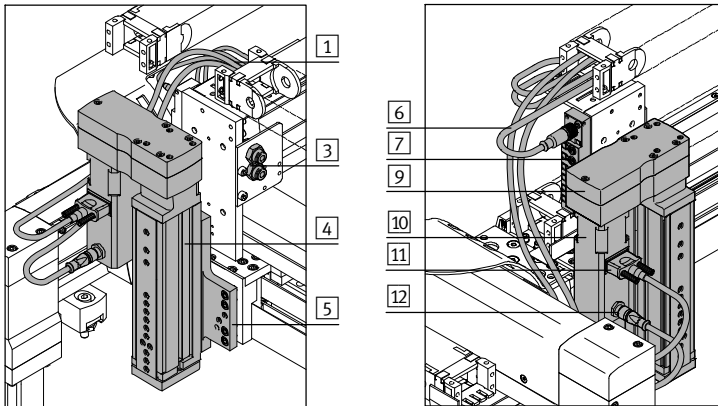

Components	Number of components
1 Tubing	2
3 Bulkhead fitting	2
4 Mini slide EGSL ¹⁾	1
5 Adapter plate	1
6 Plug socket with cable	1
7 Multi-pin plug distributor (6-way)	1
9 Parallel kit	1
10 Motor	1
11 Motor cable	1
12 Encoder cable	1
- Earthing cable	2

1) For EXCM-40, the mini slide EGSL-45 is used with a lead of 10 mm.
Further information → Internet: egsl

Planar surface gantries EXCM-40

Peripherals overview

FESTO

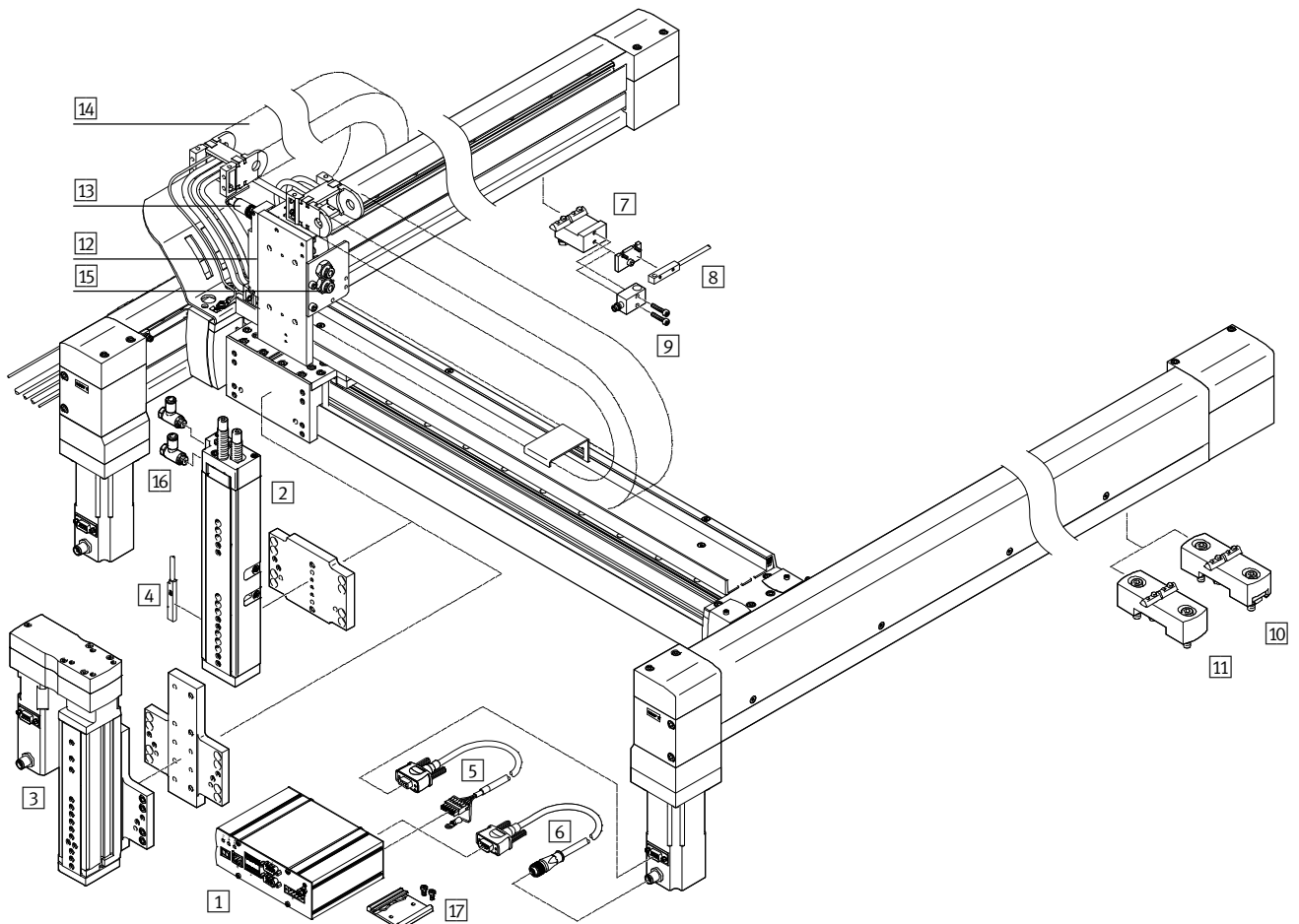

Proximity sensor for sensing the position of the slide on the Y-axis

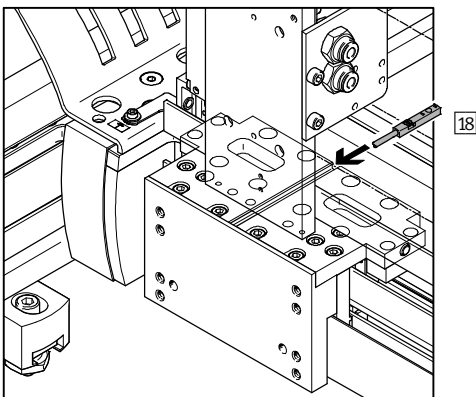

Planar surface gantries EXCM-40

Peripherals overview

Attachments and accessories		
Type	Description	→ Page/Internet
1 Controller CMXH	<ul style="list-style-type: none"> For controlling the planar surface gantry 	cmxh
2 Mini slides P1, P2, P3	<ul style="list-style-type: none"> Pneumatic attachment component (mini slide DGSL) for the Z-axis 	40
3 Mini slides HE1	<ul style="list-style-type: none"> Electric attachment component (mini slide EGSL) with motor cable NEBM and encoder cable NEBM for the Z-axis 	40
4 Proximity sensor SME-10M/SIES-8M	<ul style="list-style-type: none"> For position sensing on the Z-axis Included in the scope of delivery of the planar surface gantry EXCM-...-P... 	50
5 Motor cable NEBM	<ul style="list-style-type: none"> Connecting cable between motor and controller CMXH-ST2 Included in the scope of delivery of the planar surface gantry EXCM-...-ST/-SB 	40
6 Encoder cable NEBM	<ul style="list-style-type: none"> Connecting cable between encoder and controller CMXH-ST2 Included in the scope of delivery of the planar surface gantry EXCM-...-ST/-SB 	40
7 Sensor mounting EAPR	<ul style="list-style-type: none"> For mounting the proximity sensors SIES-Q8B, SIES-V3B on the X-axis Not included in the scope of delivery of the planar surface gantry 	49
8 Proximity sensor SIES-Q8B	<ul style="list-style-type: none"> For position sensing on the X-axis Not included in the scope of delivery of the planar surface gantry 	51
9 Proximity sensor SIES-V3B	<ul style="list-style-type: none"> For position sensing on the X-axis Not included in the scope of delivery of the planar surface gantry 	51
10 Adjusting kit EADC-12	<ul style="list-style-type: none"> Height-adjustable mounting kit for the planar surface gantry Included in the scope of delivery of the planar surface gantry. If no adjusting kit is selected in the modular product system, the mounting kit will automatically be delivered 	48
11 Mounting kit EAHM-E12	<ul style="list-style-type: none"> Non-height-adjustable mounting kit for the planar surface gantry 	48
12 Multi-pin plug distributor NEDU	<ul style="list-style-type: none"> For connecting up to 6 inputs/outputs Included in the scope of delivery of the planar surface gantry 	nedu
13 Plug socket with cable SIM	<ul style="list-style-type: none"> Connecting cable between multi-pin plug distributor NEDU and the controller Included in the scope of delivery of the planar surface gantry 	sim
14 Energy chain	<ul style="list-style-type: none"> For EXCM-40: type IGUS 250Q03.075.0 	-
15 Plastic tubing PUN-H-6x1	<ul style="list-style-type: none"> Two pieces of tubing are connected to the bulkhead fittings and routed in the energy chains at delivery (for pneumatic Z-axis, one tube on the valve and one on the bulkhead fitting) 	pun
16 One-way flow control valve GRLA	<ul style="list-style-type: none"> For speed regulation Included in the scope of delivery of the planar surface gantry EXCH-...-P... 	40
17 H-rail mounting CAFMD3	For mounting the controller to an H-rail to EN 50022	43
18 Proximity sensor SIES-8M	<ul style="list-style-type: none"> For position sensing on the Y-axis Not included in the scope of delivery of the planar surface gantry 	50
- Motor cable NEBM-S1G9	<ul style="list-style-type: none"> Connecting cable between the motor on the Z-axis and the motor controller CMMS-ST The motor controller and connecting cable are included in the scope of delivery of the planar surface gantry EXCM-...-HE1 	51
Encoder cable NEBM-M12G8	<ul style="list-style-type: none"> Connecting cable between the encoder on the Z-axis and the motor controller CMMS-ST The motor controller and connecting cable are included in the scope of delivery of the planar surface gantry EXCM-...-HE1 	51

Planar surface gantries EXCM-40

Technical data

FESTO

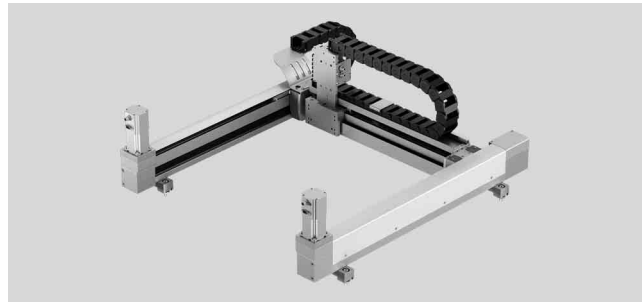

General technical data		
Design	Planar surface gantry	
Guide	Recirculating ball bearing guide	
Stroke of the		
X-axis	[mm]	200 ... 2000
Y-axis	[mm]	200 ... 1000
Z-axis	[mm]	50, 100, 150
EXCM-...-HE1	[mm]	100
EXCM-...-P1	[mm]	50
EXCM-...-P2	[mm]	100
EXCM-...-P3	[mm]	150
Rated load for max. dynamic response ¹⁾	[kg]	4
Process force in Z direction	[N]	450
Max. torque ²⁾	→ page 31	
Max. no-load torque ²⁾³⁾	→ page 31	
Max. acceleration ⁴⁾		
With motor and controller	[m/s ²]	→ page 31
Purely mechanical system	[m/s ²]	20
Max. speed ⁴⁾		
With motor and controller	[m/s]	1
Purely mechanical system	[m/s]	2
Repetition accuracy	[mm]	±0.1
Mounting position	Horizontal	
Type of mounting	Mounting kit, adjusting kit	

- 1) Rated load = tool load (attachment component (Z-axis) + gripper, for example) + payload
- 2) These values must also be complied with during installation of third-party motors
- 3) At v=0.2 m/s and 45° travel.
- 4) These data apply only under ideal conditions.
For a precise configuration, please consult a sales engineer from Festo.
Further information → page 31

Operating and environmental conditions		
Degree of protection	IP40	
Ambient temperature ¹⁾	[°C]	+10 ... +50
Storage temperature	[°C]	-10 ... +60
Relative humidity	[%]	0 ... 90 (non-condensing)
Noise level	[dB(A)]	65
Duty cycle	[%]	100
CE marking (see declaration of conformity)	To EC Machinery Directive	

- 1) Note operating range of proximity sensors and motors

Planar surface gantries EXCM-40

Technical data

Materials

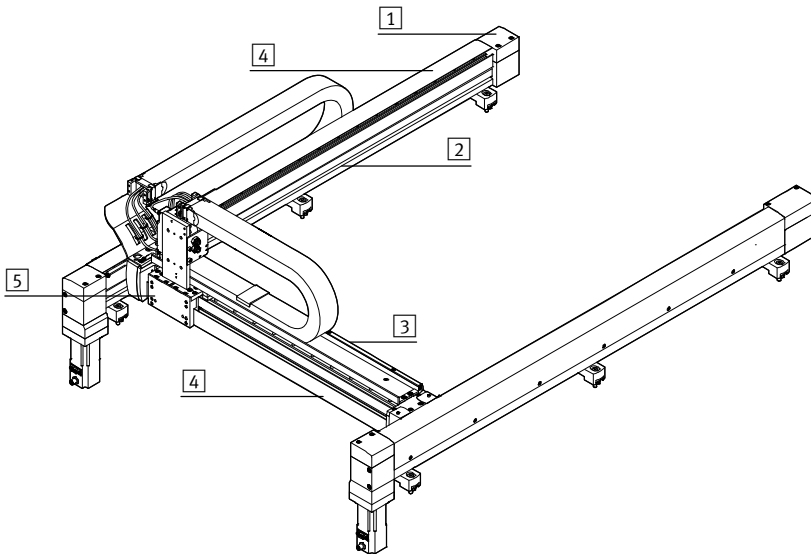

Size	40	
1	Drive and end caps	Aluminium
2	Profiles of the X-axis	Aluminium
3	Profile of the Y-axis	Aluminium
4	Cover	
	X-axis	Aluminium
	Y-axis	Aluminium
5	Slides	Aluminium
-	Coupling	Aluminium with elastomer ring gear
	Guide	Steel
	Drive pinion	Steel
	Ball bearings	Steel
	Toothed belt	PU with steel cord
	Note on materials	RoHS compliant
		Contains paint-wetting impairment substances

Planar surface gantries EXCM-40

Technical data

Weight [kg]	
Product weight with 0 mm stroke (without rated load, motors, axial kits, mounting kits)	
EXCM-...-W-T	16.7
EXCM-...-W-B	17.5
X-axis (2x)	8.5
Y-axis (without slide)	6.2
Additional weight per 100 mm stroke	
X-axis	1.75
Y-axis	0.89
Axial kit ¹⁾	
For EMMS-ST-57-M	0.54
Motor ¹⁾	
EXCM-...-ST (without brake)	1.2
EXCM-...-SB (with brake)	1.38
Attachment component (Z-axis)	
Electrical	
EXCM-...-HE1	3.3
Pneumatic	
EXCM-...-P1	1.8
EXCM-...-P2	2.4
EXCM-...-P3	2.7
Mounting kit for X-axis	
Adjusting kit ¹⁾	0.78
Mounting kit ¹⁾	0.33

1) Weight per component

Planar surface gantries EXCM-40

Technical data

Torque M as a function of rotational speed n

Typical motor characteristic curve with nominal voltage and optimal controller.

In conjunction with:

EXCM-...-ST-...-PF (at 48 V) or EXCM-...-SB-...-PF (at 48 V)

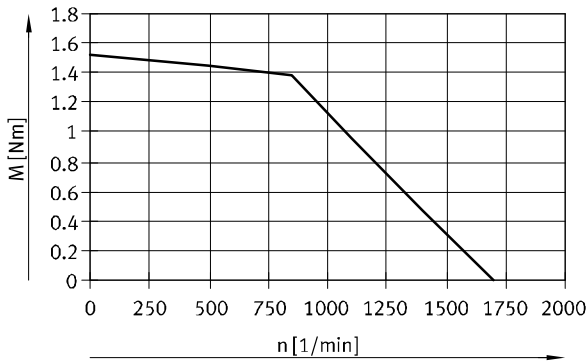

No-load torque M as a function of speed n

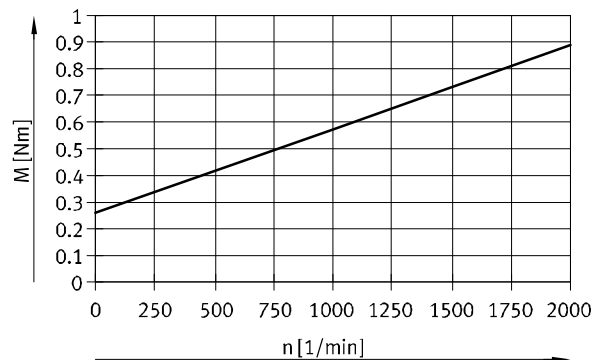

Characteristic load values

The centre of gravity of the slide is at the height of the slide in the Z-direction and in the centre of the slide in the X-/Y-directions.

The system is subject to the greatest load in the case of 45° travel.

The following data apply in this case:

Formula for calculating the required torque M and the required rotational speed n

$$M_{45^\circ} = a \times (9.79 \times m_L + 4.89 \times m_{Ay} + 10.21 \times J_m + 19.58) \times 10^{-3} + M_R$$

$$n_{45^\circ} = 975 \times v$$

a = acceleration [m/s²]

v = speed [m/s]

m_{Ay} = product weight of the Y-axis [kg]

→ page 30

m_L = attachment component (Z-axis) [kg]
with payload

J_m = moment of inertia of the motor [kgcm²]

→ table below

M_R = no-load torque [Nm]

→ page 31

n_{45°} = rotational speed at 45° travel [rpm]

Combination of planar surface gantry with servo motor for X-/Y-axis

Planar surface gantry	Motor	Moment of inertia of motor [kgcm ²]
EXCM-40-...-ST	EMMS-ST-57-M-SE-G2	0.48
EXCM-40-...-SB	EMMS-ST-57-M-SEB-G2	0.5

Planar surface gantries EXCM-40

Technical data

FESTO

Sample calculation

Given:

Planar surface gantry
EXCM-40-1000-500-KF-SB-B-PF7-HE1-...
with attached motor
EMMS-ST-57-M-SEB-G2

$$a_{\max} = 2 \text{ m/s}^2$$

$$v_{\max} = 0.5 \text{ m/s}$$

Payload = 0.5 kg

Attachment component Z-axis: EGSL-BS-45-100-10P

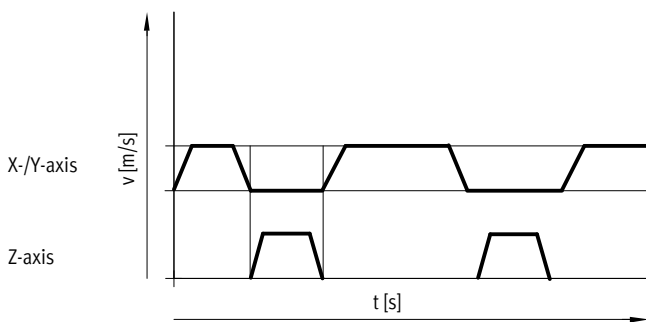

Is the attached motor sufficient for this load?

Given:

$$a_{\max} = 2 \text{ m/s}^2$$

$$v_{\max} = 0.5 \text{ m/s}$$

$$m_{Ay} = 10.65 \text{ kg}$$

$$m_L = 3.80 \text{ kg}$$

$$J_m = 0.5 \text{ kgcm}^2$$

$$M_{45^\circ} = a \times (9.79 \times m_L + 4.89 \times m_{Ay} + 10.21 \times J_m + 19.58) \times 10^{-3} + M_R$$

$$n_{45^\circ} = 975 \times v$$

a = acceleration [m/s²]

→ page 28

v = speed [m/s]

m_{Ay} = product weight of the Y-axis [kg]

→ page 30

m_L = attachment component (Z-axis) [kg]

with payload

J_m = moment of inertia of the motor [kgcm²]

→ page 31

M_R = no-load torque [Nm]

→ page 31

n_{45° = rotational speed at 45° travel [rpm]

-  - Note

These requirements for the dynamic response apply to 45° travel. For travel only in the X- or Y-direction, the dynamic values may be higher.

Planar surface gantries EXCM-40

Technical data

Sample calculation

Determination of M_R :

$$n_{45^\circ} = 975 \times 0.5 \text{ m/s} = 487.5 \text{ 1/min}$$

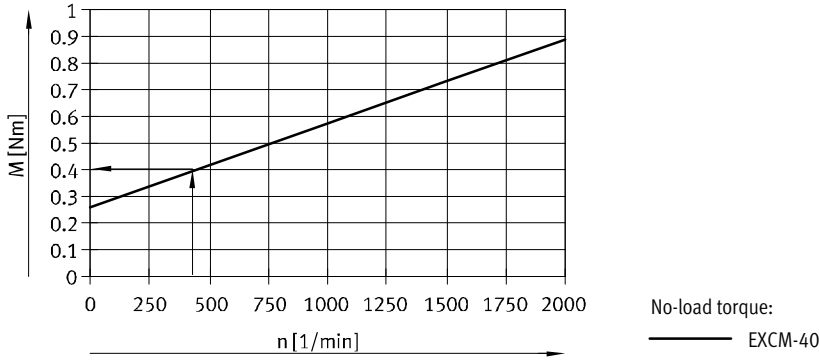

$$M_R = 0.4 \text{ Nm}$$

$$M_{45^\circ} = a \times (9.79 \times m_L + 4.89 \times m_{Av} + 10.21 \times J_m + 19.58) \times 10^{-3} + M_R$$

$$M_{45^\circ} = 2 \frac{\text{m}}{\text{s}^2} \times (9.79 \times 3.80 \text{ kg} + 4.89 \times 10.65 \text{ kg} + 10.21 \times 0.5 \text{ kgcm}^2 + 19.58) \times 10^{-3} + 0.4 \text{ Nm} = 0.63 \text{ Nm}$$

Result:

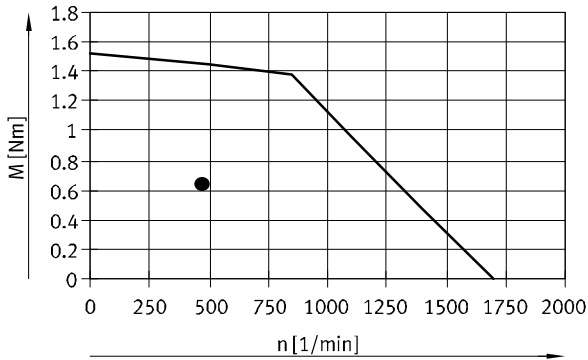

The value for the torque lies below the motor characteristic curve.

The design is thus acceptable.

Planar surface gantries EXCM-40

Technical data

Minimum number of profile mountings

Irrespective of the mounting position, a different number of profile mountings needs to be used depending on the stroke of the X-axis. The item is delivered with the required number attached.

Stroke of the X-axis [mm]	Number of profile mountings per axis
200 ... 499	2
500 ... 899	2
900 ... 1799	3
1800 ... 2000	4

Distances between the profile mountings

The profile mountings must be evenly spaced by distance l.

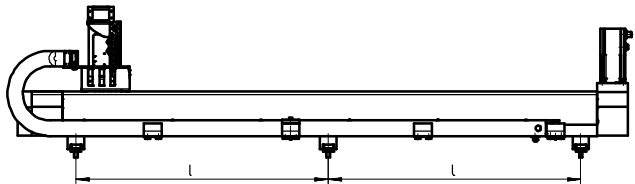

$$\text{Distance } l = \frac{\text{Stroke} + 141}{n - 1}$$

n = number of profile mountings per axis

Mounting position of the Z-axis

Owing to manufacturing tolerances and the backlash in the guides, the angle between the X- and Z-axes may not be exactly 90° in certain circumstances.

Max. deviation:
 $\alpha = \pm 1.1^\circ$

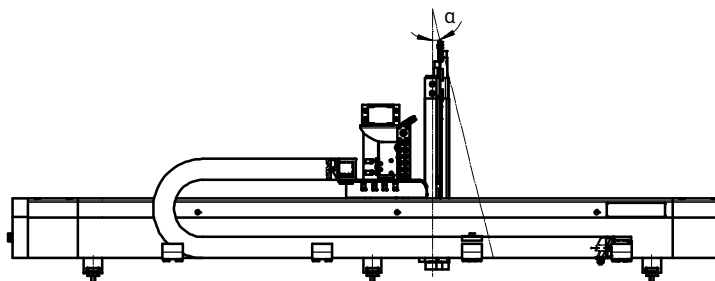

Planar surface gantries EXCM-40

Technical data

Pin allocations

Motors on the X-/Y- and Z-axes

Motor

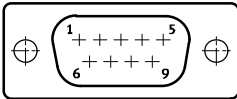

Encoder

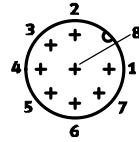

PIN	Function
1	String A
2	String A/
3	String B
4	String B/
5	n.c.
6	n.c.
7	Brake (24 V)
8	Brake (0 V)
9	-

PIN	Function
1	Signal trace A
2	Signal trace A/
3	Signal trace B
4	Signal trace B/
5	0 V
6	Signal trace N
7	Signal trace N/
8	5 V

Selection of cable lengths

2 cable lengths (5 m or 10 m) can be selected using the modular product system → page 40. This specification relates to the output of the energy chain at the X-axis (dimension L) and describes the minimum length by which the cables and tubing protrude. The selected length applies to the following components:

- Tubing
- Plug sockets with cable
- Motor cables
- Encoder cables
- Earthing cables

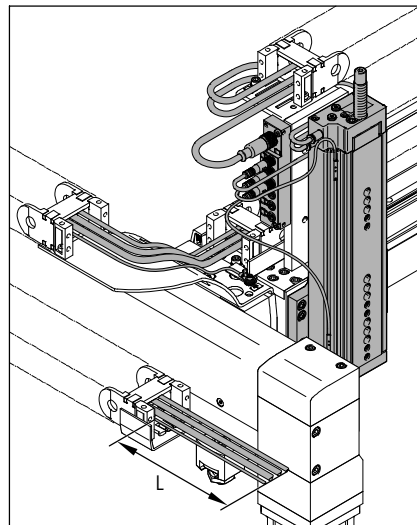

Planar surface gantries EXCM-40

Technical data



Dimensions

Download CAD data → www.festo.com

EXCM-40-...-T – Motor attachment position on top

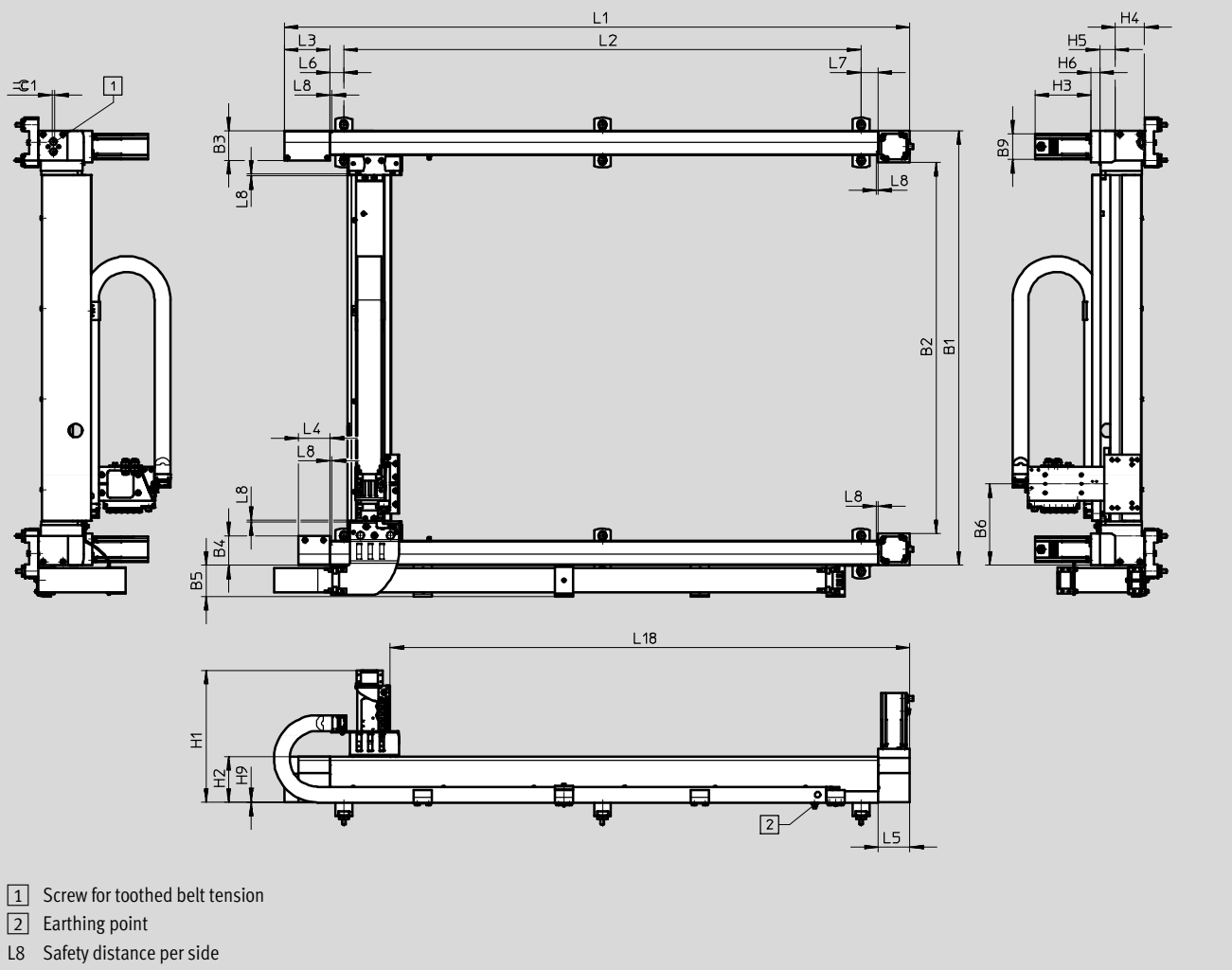

EXCM-40-...-B – Motor attachment position underneath

EXCM-40-... – Motor interface

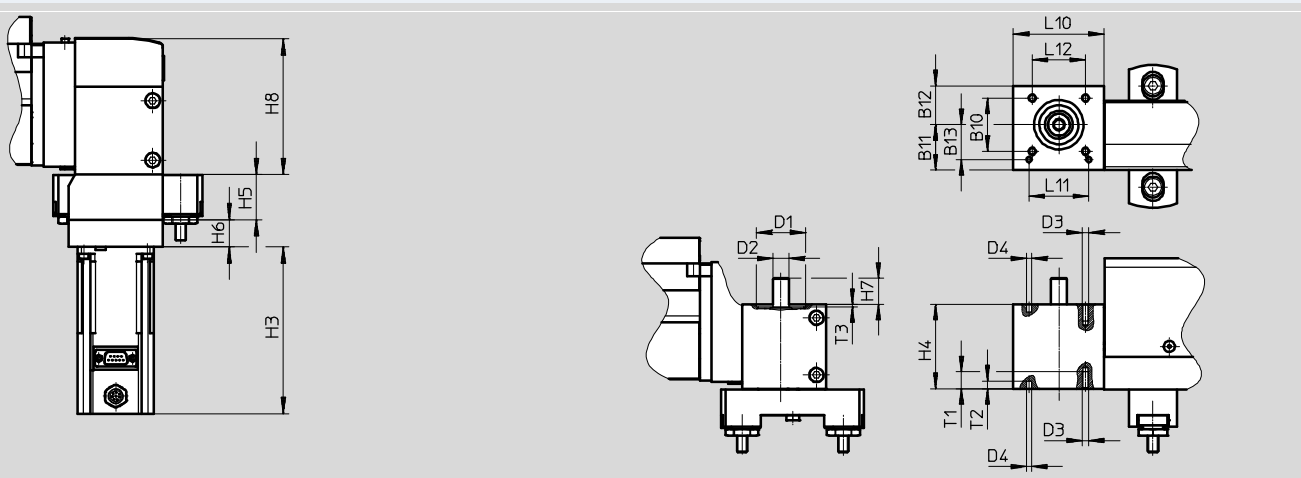

Planar surface gantries EXCM-40

Technical data

Dimensions

Download CAD data → www.festo.com

EXCM-40-... – Slide

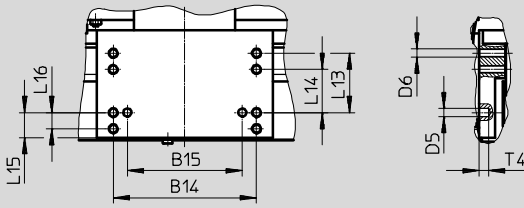

Type	B3	B4	B5	B6	B9	B10	B11	B12	B13	B14
									±0.05	±0.1
EXCM-40	65	65	69	179.9	56.4	41	35	30	27	106

Type	B15	D1	D2	D3	D4	D5	D6	H1	H2	H3
	±0.03	∅ H7	∅ H6		∅ H7	∅ H7				
EXCM-40	85	38	12	M5	4	6	M6	Approx. 293	100.8	124/159.5 ¹⁾

Type	H4	H5	H6	H7	H8	H9	L3	L4	L5	L6	L7	L8
EXCM-40	65	33.6	20	20	100.3	0.5	101	70	70	30.5	37.5	6

Type	L10	L11	L12	L13	L14	L15	L16	T1	T2	T3	T4	≈C1
		±0.03		±0.1	±0.1		±0.1					
EXCM-40	70	46	41	44	32	18.5	12	12	6	1.9	7	6

Stroke-dependent dimensions

Stroke of the X-axis	L1	L2	L18	Stroke of the Y-axis	B1	B2
200 ... 2000	382+stroke	→ page 34	167.2+stroke	200 ... 1000	360+stroke	230+stroke

1) With brake

Note

Depending on the stroke of the X-axis, a varying number of profile mountings is required. The distance between the profile mountings must always be the same (→ page 34).

The tension of the toothed belt must be set before commissioning. The tools required to do this (e.g. frequency meter) are not included in the scope of delivery.

Planar surface gantries EXCM-40

Technical data



Dimensions

Download CAD data → www.festo.com

EXCM-40-...-P...

EXCM-40-...-HE1...

With pneumatic attachment component (mini slide DGSL)

With electric attachment component (mini slide EGSL)

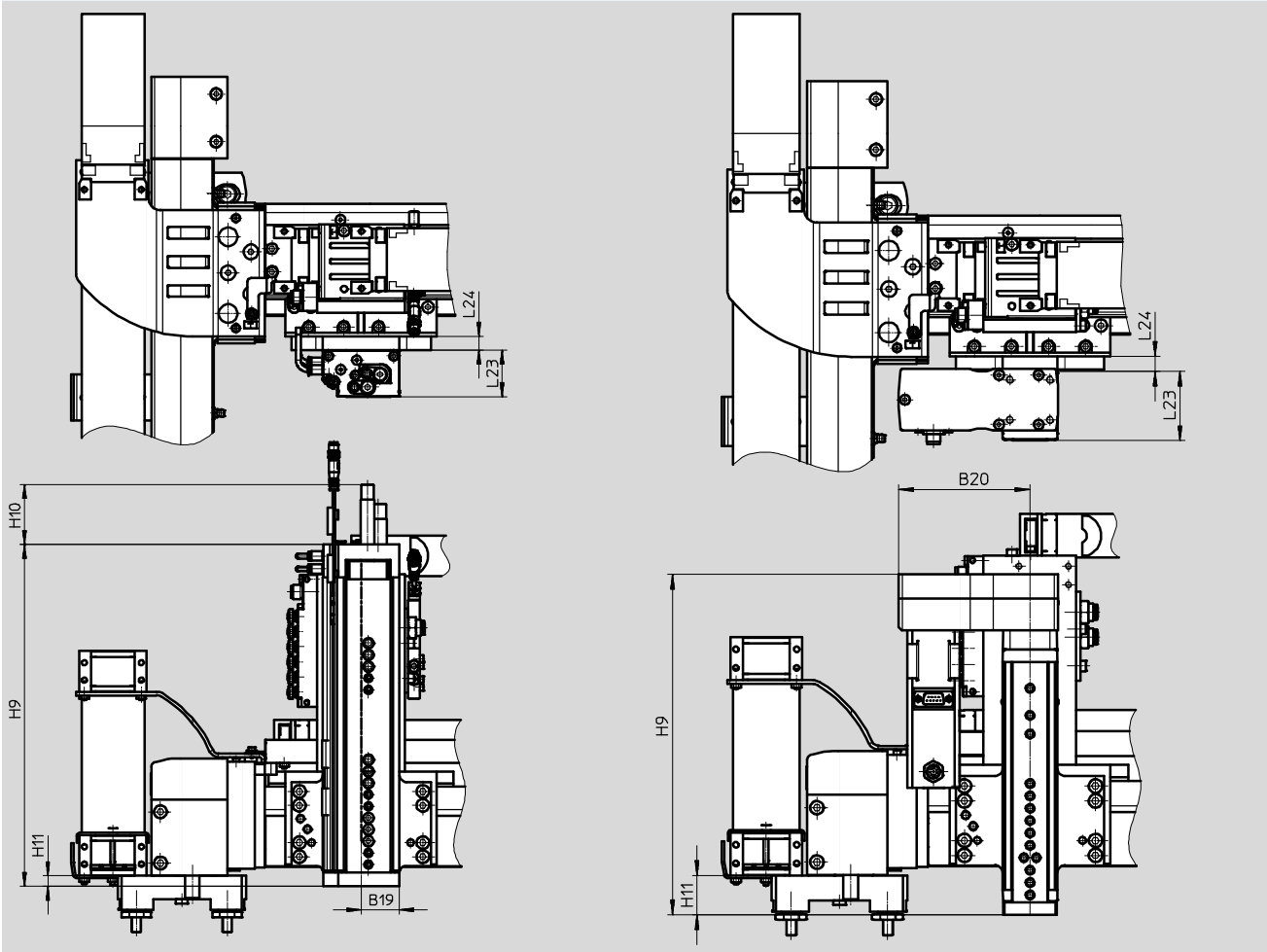

Type	B19	B20	H9	H10 max.	H11	L23	L24
With pneumatic attachment component (mini slide DGSL)							
EXCM-40-...-P1	33	-	164.6	51.9	9.1	40±0.08	12
EXCM-40-...-P2			243.6				
EXCM-40-...-P3			293.6				
With electric attachment component (mini slide EGSL)							
EXCM-40-...-HE1	-	106	275	-	31.5	56	12

Planar surface gantries EXCM-40

Technical data

Allocation of planar surface gantry to servo motor for X-/Y-axis	
Planar surface gantry	Motor
EXCM-40-...-ST	EMMS-ST-57-M-SE-G2
EXCM-40-...-SB	EMMS-ST-57-M-SEB-G2

Allocation of planar surface gantry to servo motor for Z-axis	
Planar surface gantry	Motor
EXCM-40-...-HE1	EMMS-ST-42-S-SEB-G2

 - Note

Third-party motors with a driving torque that is too high can damage the planar surface gantry. When selecting the motors, please observe the limits specified in the technical data.

Planar surface gantries EXCM-40

Ordering data – Modular product system

Ordering table				
Size	40	Conditions	Code	Entry code
M Module no.	3741955			
Product type	EXCM series M		EXCM	EXCM
Size	40		-40	-40
Stroke of the X-axis [mm]	200 ... 2000			
Stroke of the Y-axis [mm]	200 ... 1000			
Guide	Recirculating ball bearing guide		-KF	-KF
Motor type	Stepper motor with brake		-SB	
	Stepper motor		-ST	
	Without motor		-W	
Motor attachment position	Underneath		-B	
	Top		-T	
O Controller	Without			
	Remote, PNP (48 V)		-PF	
Cable length	Without			
	5 m		6	
	10 m		7	
Attachment components	None			
	Electric lifting unit, 100 mm stroke		-HE1	
	Pneumatic lifting unit, 50 mm stroke		-P1	
	Pneumatic lifting unit, 100 mm stroke		-P2	
	Pneumatic lifting unit, 150 mm stroke		-P3	
Mounting kit	With mounting kit			
	With adjusting kit		-J	
M Document language	German		-DE	
	English		-EN	
	Spanish		-ES	
	French		-FR	
	Italian		-IT	
	Russian		-RU	
	Swedish		-SV	
	Chinese		-ZH	

 Note
In combination with key feature W (without motor), the EXCM planar surface gantry is provided without a coupling housing and without a coupling.

 Note
The planar surface gantry can only be operated with the controller CMXH and a load voltage of 48 V.

- M** Mandatory data
- O** Options

Transfer order code

Planar surface gantries EXCM

Controller – Technical data

Controller EXCM-...-E...

For sizes 30

Configuration support

via FCT plug-in EXCM

Technical data → table below

Controller EXCM-...-PF...

For sizes 30 and 40

Configuration support

via FCT plug-in CMXH

Technical data → Internet: cmxh



Technical data – Controller	
Operational principle	Cascade controller P position controller, PI speed controller, PI current regulator; Current regulation inside the cascade controller PWM MOSFET power output stage
Operating mode	Direct operation Set selection
Rotary position encoder	Optical encoder, 2000 steps/rev.
Status display	7-segment display LED
Encoder interface input	RS422
Adjustable current reduction	Via software
Nominal current setting	Via software
Step adjustment	Via software
Braking resistor	[Ω] 15
Mains filter	Integrated

Electrical data – Controller	
For EXCM size	30
Load supply	
Nominal voltage	[V DC] 24 ±15%
Nominal current	[A] 6
Maximum peak current	[A] 8
Logic supply	
Nominal voltage	[V DC] 24 ±15%
Maximum peak current	[A] 0.3
Maximum peak current per digital output	[A] 0.1
Characteristics of digital logic outputs	Not galvanically isolated
Characteristics of logic inputs	Galvanically connected to logic potential
Logic input specification	Based on IEC 61131-2
Switching logic	NPN (negative switching)
Protective function	I ² t monitoring, following error monitoring, software end-position detection, voltage failure detection, current monitoring, temperature monitoring

Technical data – Fieldbus interface			
Interfaces	I/O	CANopen	Ethernet
Number of digital logic outputs	5		
Number of digital logic inputs	9		
Operating range of logic inputs	[V DC] 8 ... 30		
Process interfacing	31 records		
Communication profile	–	FHPP	FHPP (via TCP/IP – CVE)
Max. fieldbus transmission rate	[Mbit/s] –	1	100
Bus connection	Bushing, 15-pin, Sub-D	Plug connector, 9-pin, Sub-D	RJ45

Planar surface gantries EXCM

Controller – Technical data



Pin allocation for Controller EXCM-...-E...

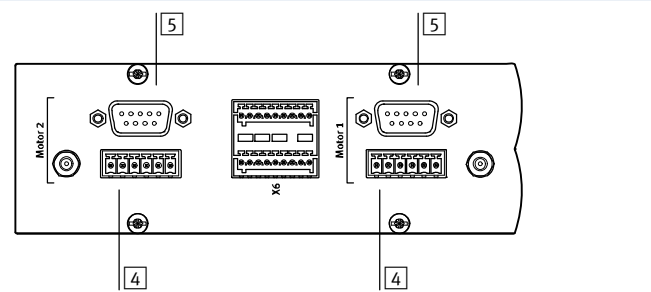
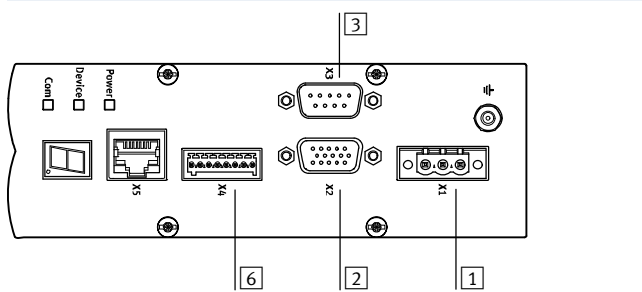

1 X1 Power supply

PIN	Function
1	+24 V logic Logic supply
2	+24 V load Load supply
3	0 V Reference potential

2 X2 I/O interface

PIN	Function
1	+24 V Ready Ready for communication
2	In 1 Positioning record bit 1
3	In 2 Positioning record bit 2
4	In 3 Positioning record bit 3
5	In 4 Positioning record bit 4
6	In 5 Positioning record bit 5
7	In 6 Not used
8	Start Move to the right
9	Enable Enable input
10	Reset Reset input
11	Ready Ready output
12	Fault Fault output
13	Acknowledge Acknowledge output
14	MC Motion complete
15	0 V Reference potential

3 X3 CAN interface

PIN	Function
1	n.c.
2	CAN_L CAN low
3	GND Reference potential
4	n.c.
5	Screening
6	n.c.
7	CAN_H CAN high
8	n.c.
9	n.c.

4 Motor connection – supply

PIN	Function
1	A String A
2	A/ String A/
3	B String B
4	B/ String B/
5	BR+ 24 V brake connection
6	BR- 0 V brake connection

5 Motor connection – encoder

PIN	Function
1	O
2	B
3	N
4	0 V Reference potential for encoder
5	5 V Auxiliary supply for encoder
6	A/
7	B/
8	N/
9	n.c.

6 X4 Emergency stop interface

PIN	Function
1	+24 V logic Logic supply
2	TO Interrupt motor voltage (at 0 V)
3	ES Trigger braking ramp (at 0 V)
4	RB Release brake (at 24 V)
5	FAULT Fault
6	DIAG1
7	DIAG2
8	0 V Reference potential

Planar surface gantries EXCM

Controller – Technical data

Dimensions for Controller EXCM-...-E...

Download CAD data → www.festo.com

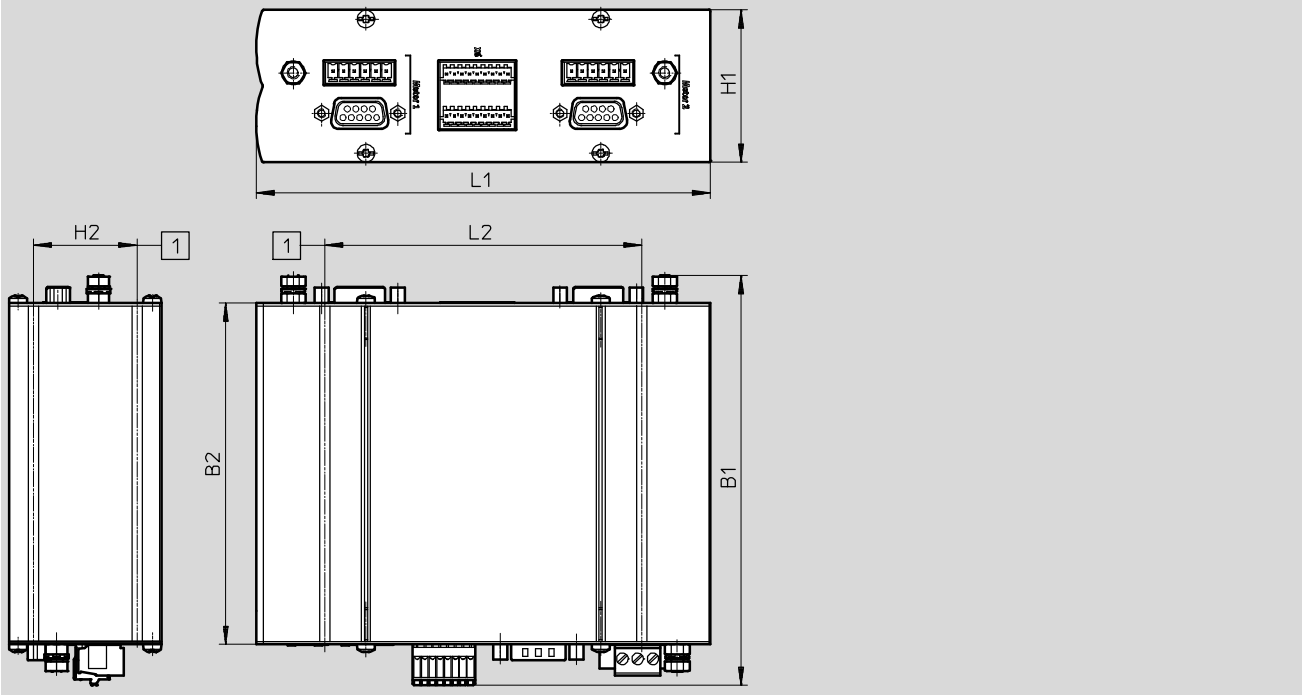

B1	B2	H1	H2	L1	L2
134.4	112	50	34	149	104

H-rail mounting CAFM

for H-rail to EN 50022

Materials:

Anodised aluminium

RoHS-compliant

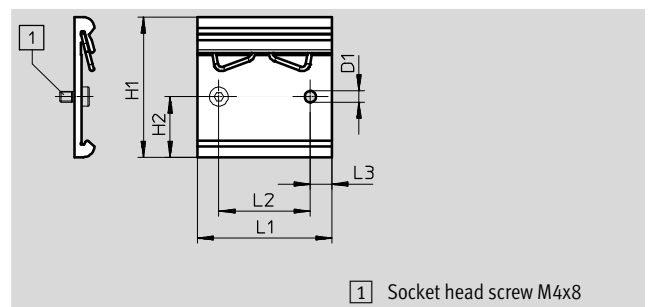

1 Socket head screw M4x8

Dimensions and ordering data

D1	H1	H2	L1	L2	L3	Weight [g]	Part No.	Type
∅ 4.2	52	22.5	50	34	8	29	4135048	CAFM-D3-H

Planar surface gantries EXCM

Accessories



Profile mounting MUE

For size 30

Materials:
Anodised aluminium
RoHS-compliant

For mounting the planar surface gantry (scope of delivery: 1 pair)

Included in the scope of delivery of the planar surface gantry:
X-stroke < 500 mm: 2 pairs
X-stroke ≥ 500 mm: 3 pairs

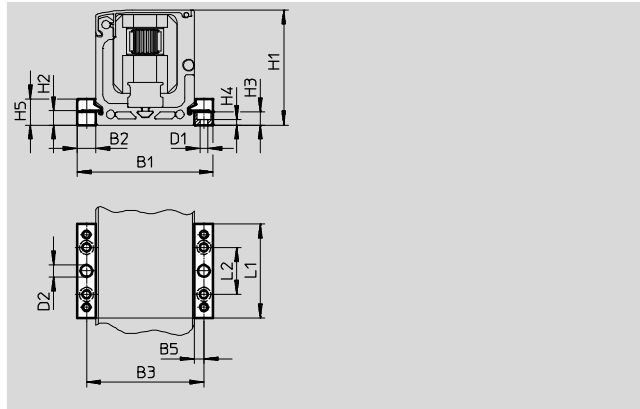
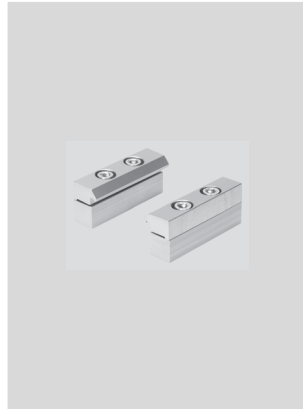

Dimensions and ordering data									
For size	B1	B2	B3	B5	D1 ∅	D2 ∅ H7	H1	H2	H3
30	58	8	50	4	3.4	5	49	6	5.5

For size	H4	H5	L1	L2	Weight [g]	Part No.	Type
30	2.3	11	40	20	20	558042	MUE-50

Adjusting kit EADC-E11

For size 30

Materials:
Anodised aluminium
RoHS compliant

For mounting and aligning the planar surface gantry. The kit is height adjustable.

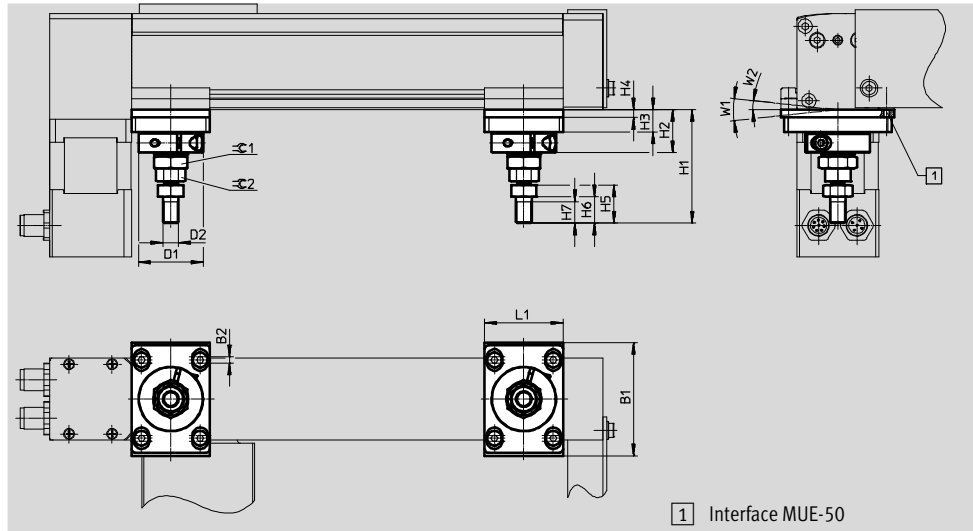

Dimensions and ordering data											
For size	B1	B2	D1 ∅	D2	H1 +12/-2	H2	H3	H4	H5	H6	H7
30	58	3	33	M8	58	22	11.5	4	19.5	13.5	11

For size	L1	W1	W2	∠C1	∠C2	Weight [g]	Part No.	Type
30	40	12°	6°	17	13	160	4706964	EADC-E11-30

Planar surface gantries EXCM

Accessories



Mounting kit EAHT-E9

For size 30

Materials:

Anodised aluminium

RoHS-compliant

Prepared hole pattern for:

- Mini slides EGSL-35
- Mini slides DGSL-8/-10/-12
- Electric cylinders EPCO-16
- Mini slides EGSC-BS-25/-32
- Electric slide EGSK-20/-26

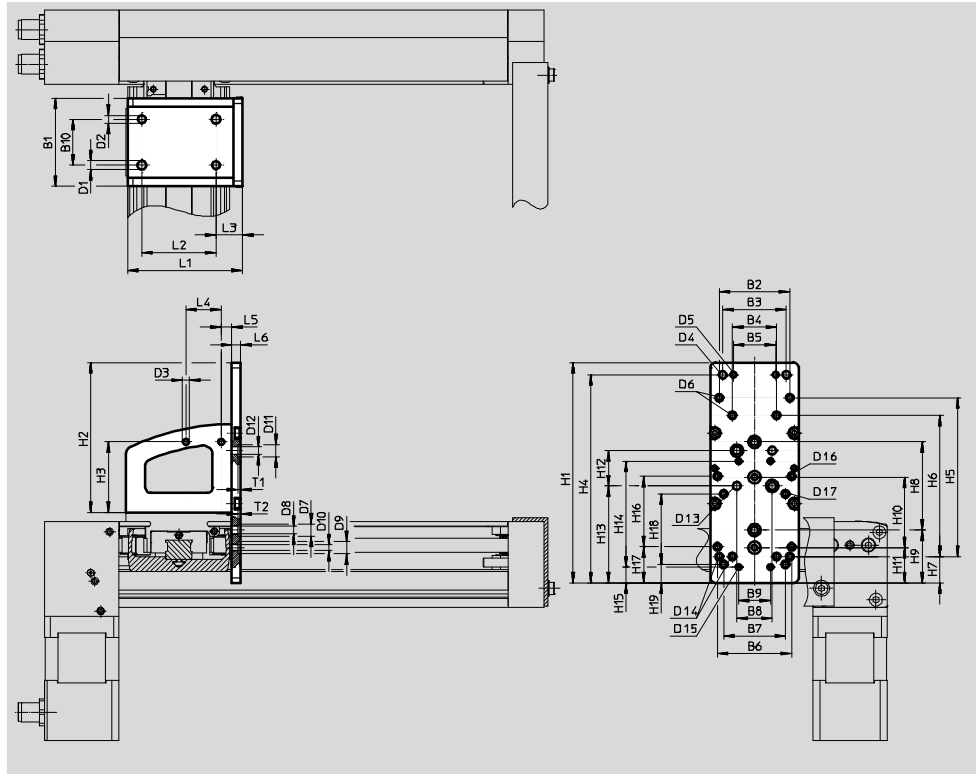

Dimensions and ordering data												
For size	B1	B2	B3	B4	B5	B6	B7	B8	B9	B10	D1 ∅ H7	D2 ∅
30	50	40	36	25	24	42	35	20	18	26	5	4.5
For size	D3	D4	D5	D6	D7 ∅ H7	D8	D9 ∅ H7	D10	D11 ∅ H7	D12 ∅	D13 ∅	D14
30	M4	M5	M4	M4	7	M5	7	M4	7	4.5	4.5	M4
For size	D15	D16	D17	H1	H2	H3	H4 ±0.2	H5	H6	H7	H8	H9
30	M3	M4	M4	125	85	40	118	90	80	15	50	30
For size	H10	H11	H12	H13	H14	H15	H16	H17	H18	H19	L1	L2
30	40	20	20	55	60	9	40	20.5	40	10.5	65	42
For size	L3	L4	L5	L6	T1 ±0.1	T2 ±0.1	Weight [g]	Part No.		Type		
30	15	20	6	5	1.6	1.6	165	4070088		EAHT-E9-FB-3D-30		

Planar surface gantries EXCM

Accessories



Sensor mounting EAPR

For size 30

(incl. switch lug)

Materials:

Holder: Wrought aluminium alloy

Switch lug: Steel

RoHS compliant

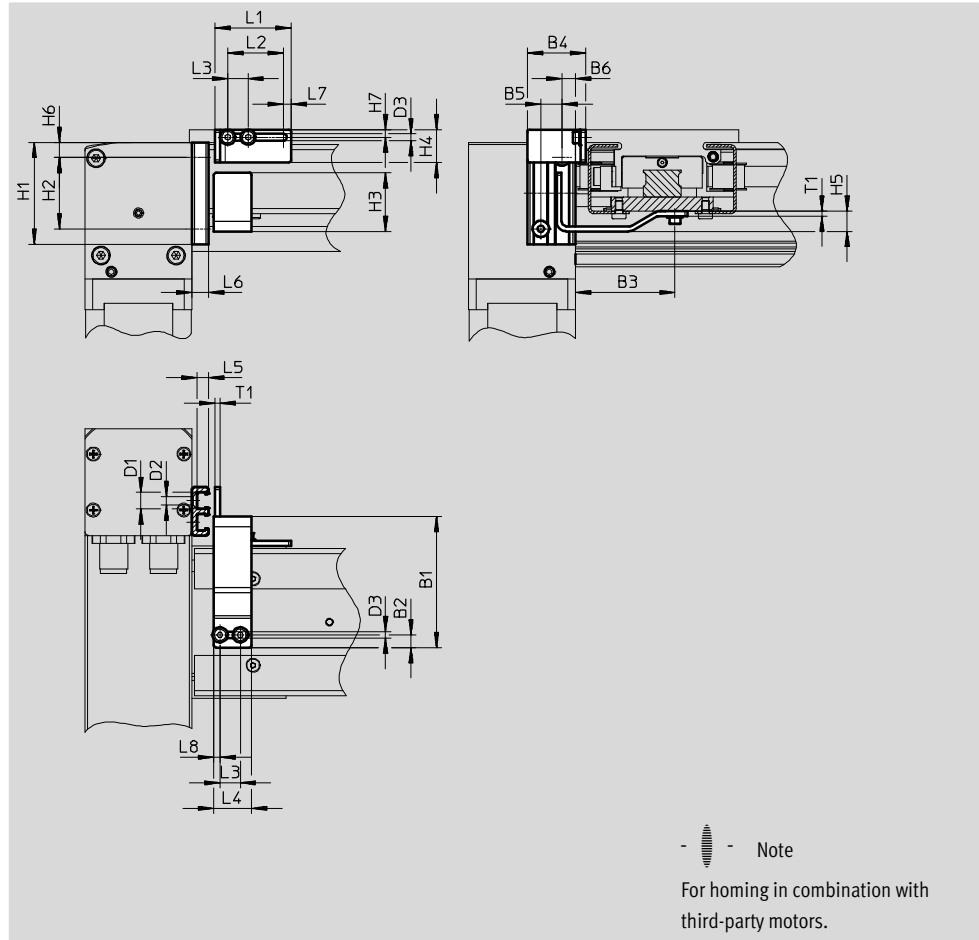
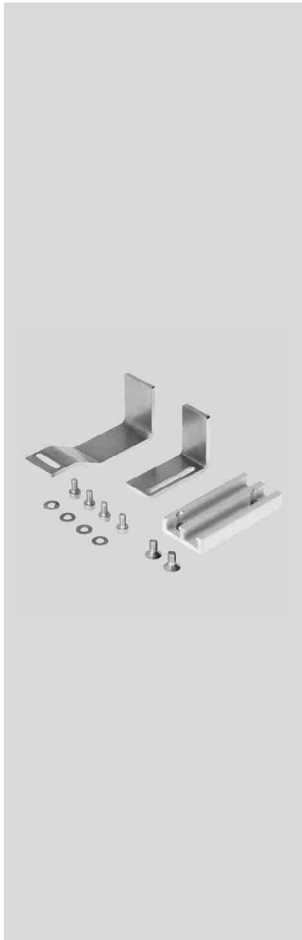

Dimensions and ordering data										
For size	B1	B2	B3	B4	B5	B6	D1 ∅	D2 ∅	D3 ∅	H1
30	51.5	5	39	23	8.4	5.3	6.5	3.4	2.6	40
For size	H2	H3	H4	H5	H6	H7	L1	L2	L3	L4
30	28	23	13	8	6	3	30	22	8	15
For size	L5	L6	L7	L8	T1	Weight [g]	Part No.	Type		
30	4.5	6.5	3	2.5	2	330	2319236	EAPR-E11-30		

Planar surface gantries EXCM

Accessories

Energy chain and connection kit for size 30

Ordering data – Energy chain

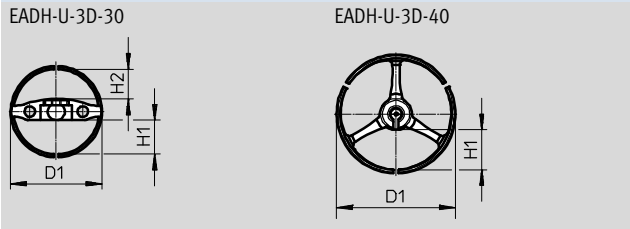

Type		D1 ∅	H1	H2
	EADH-U-3D-30	34.5	12.5	11
	EADH-U-3D-40	45	15	-

For size	Max. bending radius [mm]	Length [mm]	Weight [g]	Part No.	Type
30	50	Approx. 500	75	8059999	EADH-U-3D-30
	58	Approx. 500	100	8060324	EADH-U-3D-40

Ordering data – Connection kit

	For energy chain	Description	Part No.	Type
	EADH-U-3D-30	For mounting the energy chain.	8060325	EAHT-AE-3D-30
	EADH-U-3D-40	Included in the scope of delivery: • 2 connectors • 4 socket head screws M4x10	8060326	EAHT-AE-3D-40

Planar surface gantries EXCM

Accessories



Adjusting kit EADC-E12

For size 40

Materials:
Anodised aluminium
RoHS compliant

For mounting and aligning the planar surface gantry. The kit is height adjustable.

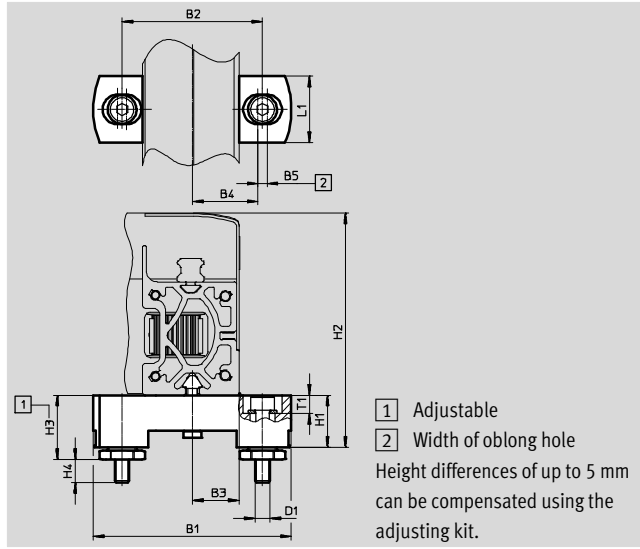
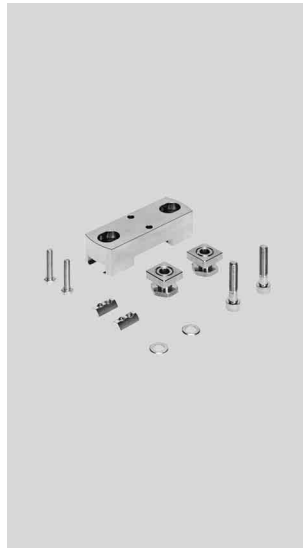

1 Adjustable
2 Width of oblong hole
Height differences of up to 5 mm can be compensated using the adjusting kit.

Dimensions and ordering data								
For size	B1	B2	B3	B4 ±0.2	B5	D1	H1	H2
40	110	78	26	36.5	5	M8	29	129.8

For size	H3		H4 max.	L1	T1 ±0.1	Weight [g]	Part No.	Type
	Min.	max.						
40	34.8	39.8	14	37	10	800	8029165	EADC-E12-40

Mounting kit EAHM-E12

For size 40

Materials:
Anodised aluminium
RoHS compliant

For mounting of the planar surface gantry. The kit is not height adjustable.

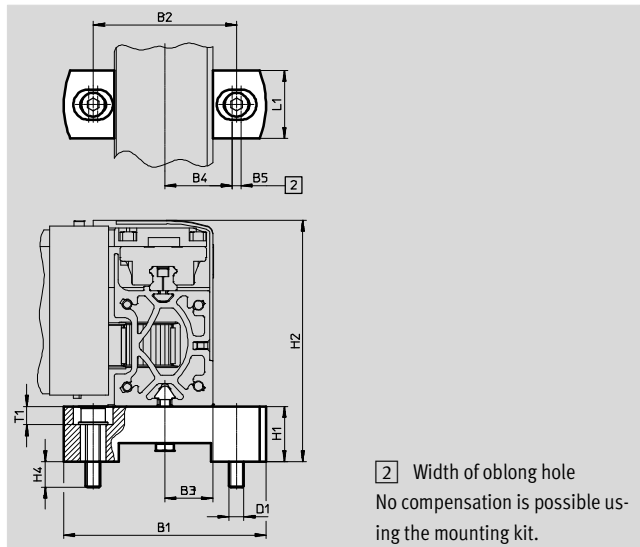
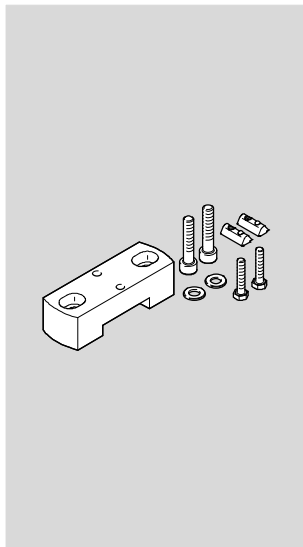

2 Width of oblong hole
No compensation is possible using the mounting kit.

Dimensions and ordering data							
For size	B1	B2	B3	B4 ±0.2	B5	D1	H1 ±0.2
40	110	78	26	36.5	5	M8	30

For size	H2	H4 max.	L1	T1 ±0.1	Weight [g]	Part No.	Type
40	131.3	14	37	10	330	3489340	EAHM-E12-K-40

Planar surface gantries EXCM

Accessories

Sensor mounting EAPR

For size 40

Materials:

Switch lug: Steel

Sensor bracket: Wrought aluminium alloy

RoHS-compliant

For proximity sensor

SIES-V3B and SIES-Q8B

(for sensing the slide position on the X-axis)

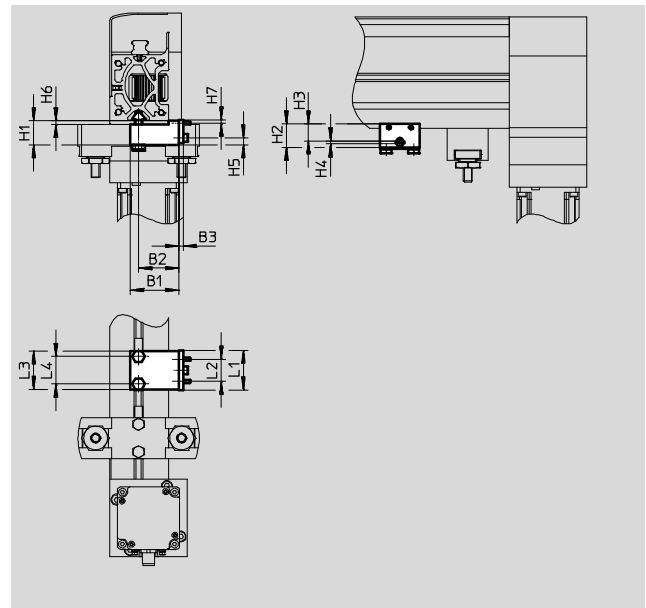
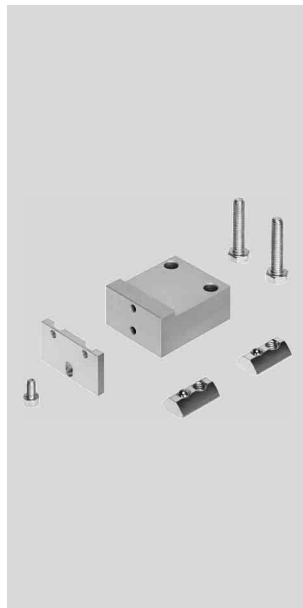

Dimensions and ordering data										
For size	B1	B2	B3	H1	H2	H3 ±0.1	H4	H5	H6 -0.1	H7 -0.2
40	44	36.3	4	21.8	21	15	2.5	6.1	3.1	3

For size	L1	L2	L3	L4	Weight [g]	Part No.	Type
40	36	20	35	25	120	2536353	EAPR-E12-40

Planar surface gantries EXCM

Accessories

FESTO

Proximity sensors for size 30

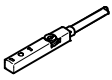
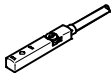
Ordering data – Proximity sensor for T-slot, inductive						Technical data → Internet: sies
	Type of mounting	Electrical connection	Switching output	Cable length [m]	Part No.	Type
N/O contact						
	Insertable in the slot from above, flush with the cylinder profile	Cable, 3-wire	PNP	7.5	551386	SIES-8M-PS-24V-K-7,5-OE
		Plug connector M8x1, 3-pin		0.3	551387	SIES-8M-PS-24V-K-0,3-M8D
		Cable, 3-wire	NPN	7.5	551396	SIES-8M-NS-24V-K-7,5-OE
		Plug connector M8x1, 3-pin		0.3	551397	SIES-8M-NS-24V-K-0,3-M8D
N/C contact						
	Insertable in the slot from above, flush with the cylinder profile	Cable, 3-wire	PNP	7.5	551391	SIES-8M-PO-24V-K-7,5-OE
		Plug connector M8x1, 3-pin		0.3	551392	SIES-8M-PO-24V-K-0,3-M8D
		Cable, 3-wire	NPN	7.5	551401	SIES-8M-NO-24V-K-7,5-OE
		Plug connector M8x1, 3-pin		0.3	551402	SIES-8M-NO-24V-K-0,3-M8D

-  - Note
For homing in combination with third-party motors.

Proximity sensors for size 40

Permissible proximity sensor for sensing the position of the slide on the Y-axis

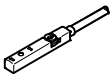
Ordering data – Proximity sensors for T-slot, inductive						Technical data → Internet: sies
	Type of mounting	Electrical connection	Switching output	Cable length [m]	Part No.	Type
	Inserted in the slot from above, flush with the cylinder profile	Plug connector M8x1, 3-pin	PNP, N/O contact	0.3	551387	SIES-8M-PS-24V-K-0,3-M8D

Permissible proximity sensors for sensing the positions on the Z-axis

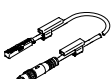
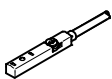
Ordering data – Proximity sensors for T-slot						Technical data → Internet: smt
	Type of mounting	Electrical connection	Switching output	Cable length [m]	Part No.	Type
With mini slide DGSL (magneto-resistive)						
	Inserted in the slot from above, flush with the cylinder profile	Plug connector M8x1, 3-pin	PNP, N/O contact	0.3	551367	SME-10M-DS-24V-E-0,3-L-M8D
With mini slide EGSL (inductive)						
	Inserted in the slot from above, flush with the cylinder profile	Plug connector M8x1, 3-pin	PNP, N/O contact	0.3	551387	SIES-8M-PS-24V-K-0,3-M8D

Planar surface gantries EXCM

Accessories

FESTO

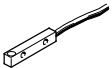

Permissible proximity sensors in combination with sensor mounting EAPR-E12

Ordering data – Proximity sensors				Technical data → Internet: sies	
	Type of mounting	Electrical connection	Switching output	Part No.	Type
N/O contact					
	Screwed on	Plug connector M8x1, 3-pin	PNP	150491	SIES-V3B-PS-S-L
N/C contact					
	Screwed on	Cable, 3-wire	NPN	174550	SIES-Q8B-NO-K-L

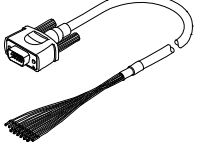
Ordering data

	Description	Cable length [m]	Part No.	Type
Control cable NEBC				
	For the I/O interface to any controller	1	2307459	NEBC-S1H15-E-1.0-N-LE15
		2.5	2052917	NEBC-S1H15-E-2.5-N-LE15
		5	2052918	NEBC-S1H15-E-5.0-N-LE15
		10	2052919	NEBC-S1H15-E-10.0-N-LE15

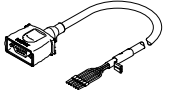
Cables for Z-axis for size 40

Ordering data				
	Description	Cable length [m]	Part No.	Type
Motor cable NEBM				
	<ul style="list-style-type: none"> - Min. bending radius: 62 mm - Suitable for use with energy chains - Ambient temp.: -40 ... +80 °C 	10	1450372	NEBM-S1G9-E-10-Q5-LE6
Encoder cable NEBM				
	<ul style="list-style-type: none"> - Min. bending radius: 51 mm - Suitable for use with energy chains - Ambient temp.: -40 ... +70 °C 	10	550749	NEBM-M12G8-E-10-S1G9
		15	550750	NEBM-M12G8-E-15-S1G9

Festo - Your Partner in Automation



1 Festo Inc.
5300 Explorer Drive
Mississauga, ON L4W 5G4
Canada

Festo Customer Interaction Center
Tel: 1 877 463 3786
Fax: 1 877 393 3786
Email: customer.service.ca@festo.com

2 Festo Pneumatic
Av. Ceylán 3,
Col. Tequesquináhuac
54020 Tlalneantla,
Estado de México

Multinational Contact Center
01 800 337 8669
ventas.mexico@festo.com

3 Festo Corporation
1377 Motor Parkway
Suite 310
Islandia, NY 11749

Festo Customer Interaction Center
1 800 993 3786
1 800 963 3786
customer.service.us@festo.com

4 Regional Service Center
7777 Columbia Road
Mason, OH 45040

Connect with us



www.festo.com/socialmedia



www.festo.com

Subject to change