

Mini slides EGSC-BS



Electromechanical drives

Selection aid

Overview of electric mini slides

- Speeds of up to 1.3 m/s
- Acceleration of up to 15 m/s²
- Repetition accuracy of up to ±0.015 mm
- Strokes of up to 300 mm
- Flexible motor mounting

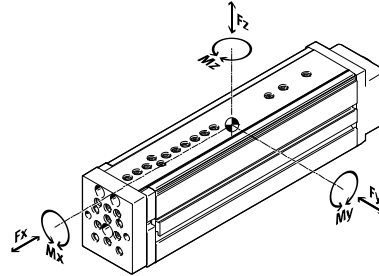

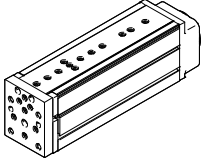
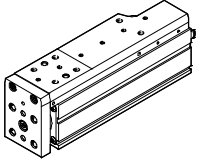
Mini slides						
Type	F_x [N]	v [m/s]	M_x [Nm]	M_y [Nm]	M_z [Nm]	Features
EGSL						
	75	0.5	6.2	6.0	6.0	<ul style="list-style-type: none"> • For the highest requirements in terms of precision and load carrying ability • Wide range of options for mounting on linear drives, grippers and rotary drives
	150	1.0	18.6	16.3	16.3	
	300	1.0	33.1	33.3	33.3	
	450	1.3	67.4	47.1	47.1	
EGSC						
	20	0.4	2.0	2.1	2.1	<ul style="list-style-type: none"> • System product from the multi-axis modular system ELGC/EGSC • Precise guide and ball screw • Compact dimensions
	60	0.5	3.4	3.2	3.2	
	120	0.6	8.1	7	7	
	250	0.6	20	30	30	

Mini slides EGSC-BS

Key features

At a glance

- The toothed belt axes, spindle axes ELGC and mini slides EGSC form a scalable modular system for compact automation
- The common platform architecture provides to an integrated range with matching interfaces. A wide variety of systems can be achieved without using any adapter plates
- High-performance drive and guide elements ensure long service life, load carrying ability and reliability
- The uniform, universal range of accessories reduces warehousing and design work
- Two position sensing functions can be selected:
 - With magneto-resistive proximity sensors SMT-8M (detection via integrated magnets)
 - With inductive proximity sensors SIES-8M (detection through switch lug EAPM)

Cantilever system

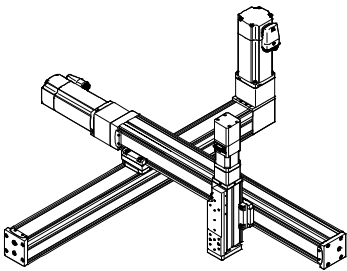

Planar surface gantry

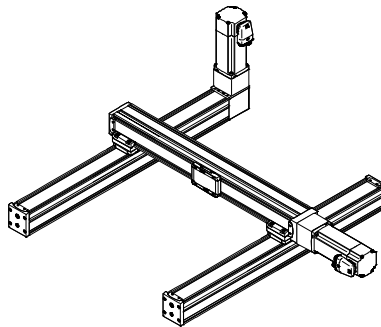

Three-dimensional gantry

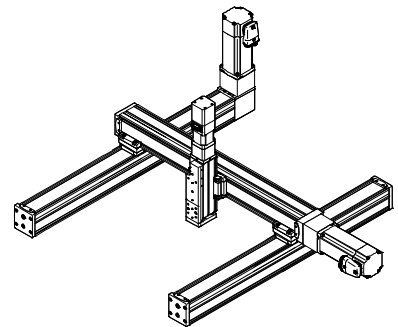

Complete system comprising motor, motor controller and motor mounting kit
Motor



- 1 Servo motor EMME-AS
- 2 Stepper motor EMMS-ST

Motor controller



- 1 Servo motor controller CMMP-AS
- 2 Stepper motor controller CMMO-ST

 **Note**
A range of specially coordinated complete solutions is available for the mini slide EGSC and the motors.

Motor mounting kit
Axial kit



Parallel kit

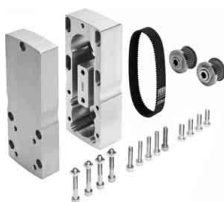

Complete kits are available for both parallel and axial motor mounting.

Mini slides EGSC-BS

Key features

Combination matrix between axis ELGC-TB, ELGC-BS, mini slide EGSC-BS and guide axis ELFC

With profile mounting EAHF-L2-...-P-D...

- For axis/axis mounting without adapter plate
- Mounting option: base axis with next smallest assembly axis

	Size	Assembly axis ELGC-BS/-TB; ELFC; EGSC-BS			
		25	32	45	60
Base axis	32	■	–	–	–
ELGC-BS/-TB; ELFC	45	–	■	–	–
	60	–	–	■	–
	80	–	–	–	■

Sample applications

Toothed belt axis ELGC-TB – Mini slide EGSC-BS

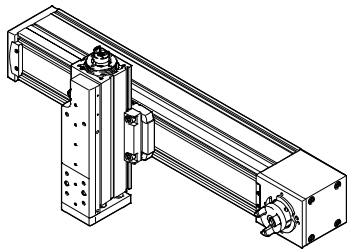

Spindle axis ELGC-BS – Mini slide EGSC-BS

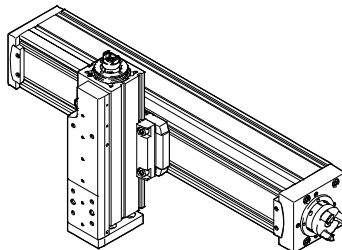

Toothed belt axis ELGC-TB – Spindle axis ELGC-BS

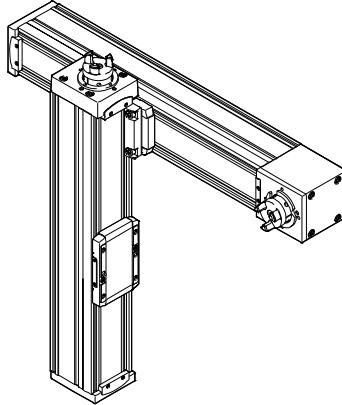
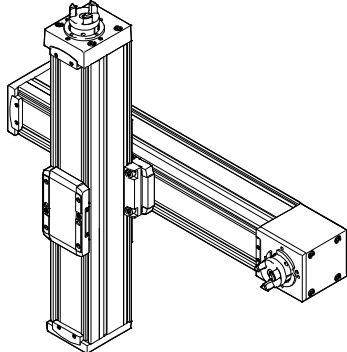

Mini slides EGSC-BS

Key features

Combination matrix between axis ELGC-TB, ELGC-BS, mini slide EGSC-BS and guide axis ELFC

With adapter kit EHAA-D-L2

- For axis/axis mounting with adapter plate
- Mounting option: base axis with the same size or next smallest assembly axis
- When motors are assembled using parallel kits, interfering contours may occur. In this case, the adapter plate is required for height compensation (download CAD data → www.festo.com)

	Size	Assembly axis ELGC-BS/-TB; ELFC; EGSC-BS				
		25	32	45	60	80
Base axis	32		■	-	-	-
ELGC-BS/-TB; ELFC	45	-		■	-	-
	60	-	-		■	-
	80	-	-	-		■

Sample applications

Toothed belt axis ELGC-TB – Mini slide EGSC-BS

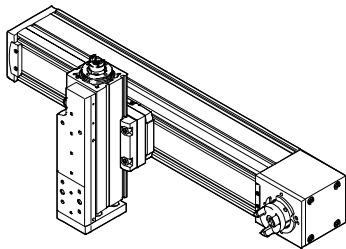

Spindle axis ELGC-BS – Mini slide EGSC-BS

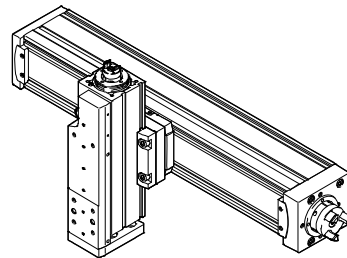

Toothed belt axis ELGC-TB – Spindle axis ELGC-BS

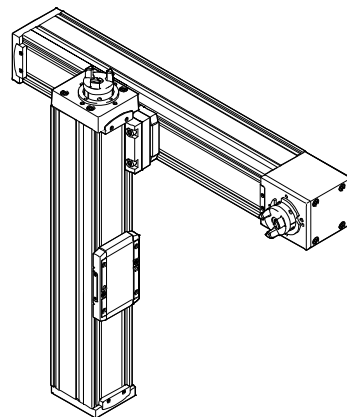
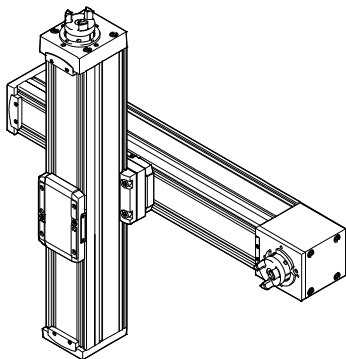

Mini slides EGSC-BS

Key features

Combination matrix between axis ELGC-TB, ELGC-BS, mini slide EGSC-BS and guide axis ELFC

With angle kit EHAA-D-L2-...-AP

- For mounting vertical axes (assembly axes) of the next size down on base axes with mounting position “slide at top”

	Size	Assembly axis ELGC-BS/-TB; ELFC; EGSC-BS			
		25	32	45	60
Base axis	32	■	–	–	–
ELGC-BS/-TB; ELFC	45	–	■	–	–
	60	–	–	■	–
	80	–	–	–	■

Sample applications

Toothed belt axis ELGC-TB – Spindle axis ELGC-BS

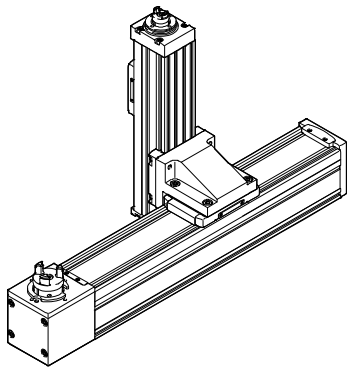

Toothed belt axis ELGC-TB – Mini slide EGSC-BS

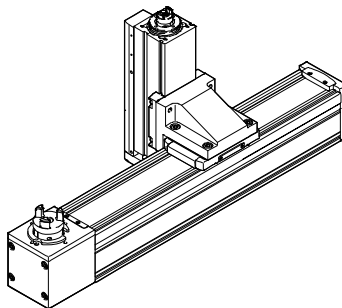

Spindle axis ELGC-BS – Mini slide EGSC-BS

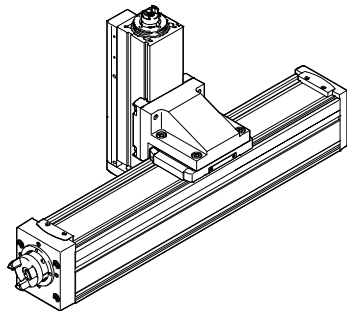

Mini slides EGSC-BS

Key features

Combination matrix between mini slide EGSC-BS and mini slide EGSC-BS

Direct mounting

		Mini slide EGSC-BS			
		25	32	45	60
Mini slide EGSC-BS	25	■	-	-	-
	32	-	■	-	-
	45	-	-	■	-
	60	-	-	-	■

Sample applications

Mini slide EGSC-BS – Mini slide EGSC-BS

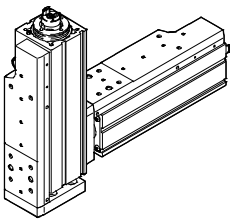

Combination matrix between mini slide EGSC-BS and rotary drive ERMO

Direct mounting

		Rotary drive ERMO			
		12	16	25	32
Mini slide EGSC-BS	32	■	-	-	-
	45	-	■	■	-
	60	-	-	■	■

Sample applications

Mini slide EGSC-BS – Rotary drive ERMO

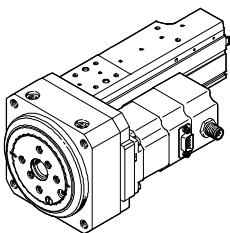

Mini slides EGSC-BS

Peripherals overview

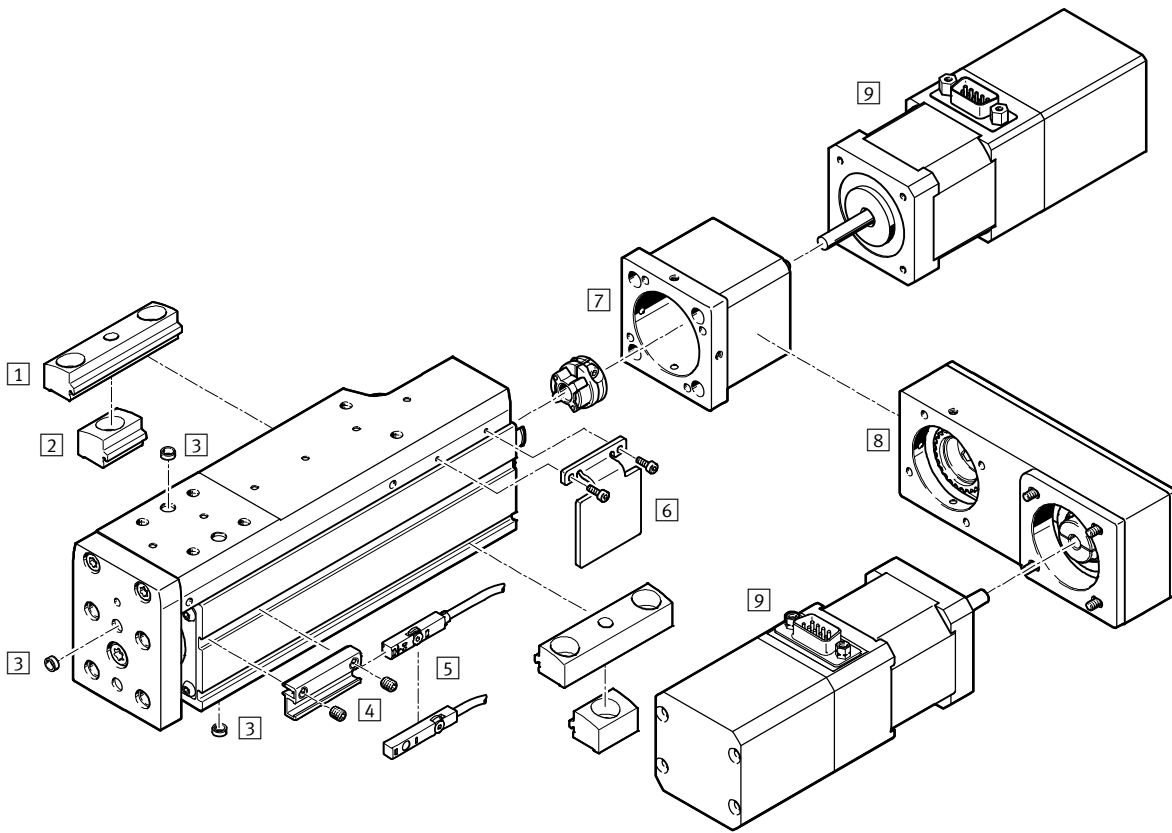

Accessories			
Type/order code	Description	→ Page/Internet	
1 Profile mounting EAHF-L2-...-P	For mounting the axis on the side of the profile. The profile mounting can be fixed in place on the mounting surface using the drill hole in the centre	22	
2 Profile mounting EAHF-L2-...-P-S	For mounting the axis on the side of the profile	21	
3 Centring pin/sleeve ZBS, ZHB	For centring loads and attachments	24	
4 Sensor bracket EAPM-L2	For mounting the proximity sensors on the axis. The proximity sensors can only be mounted using the sensor bracket	23	
5 Proximity sensor SIES-8M	Inductive proximity sensor, for T-slot	24	
Proximity sensor SMT-8M	Magnetic proximity sensor, for T-slot	24	
6 Switch lug EAPM-...-SLS	For sensing the slide position in conjunction with inductive proximity sensors SIES-8M	24	
7 Axial kit EAMM-A	For axial motor mounting	19	
8 Parallel kit EAMM-U	For parallel motor mounting	20	
9 Motors EMME-AS, EMMS-ST	Motors specially matched to the axis, with or without brake	19	

 **Note**
For sizes 45 and 60, inductive proximity sensor SIES-8M must be used for strokes greater than 100 mm.

Mini slides EGSC-BS

Type codes



		EGSC	-	BS	-	KF	-	45	-	100	-	10P
Type												
EGSC	Mini slides											
Drive system												
BS	Ball screw											
Guide												
KF	Recirculating ball bearing guide											
Size												
Stroke [mm]												
Spindle pitch [mm/rev.]												

Mini slides EGSC-BS

Technical data

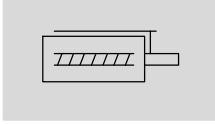
Function



-  Size
25 ... 60
-  Stroke length
25 ... 200 mm



General technical data					
Size		25	32	45	60
Design		Electric mini slide with ball screw			
Guide		Recirculating ball bearing guide			
Mounting position		Any			
Working stroke	[mm]	25, 50, 75	25, 50, 75, 100	25, 50, 75, 100, 125, 150	50, 75, 100, 125, 150, 200
Max. permissible applied load	[kg]	1	2	6	10
Max. feed force F_x	[N]	20	60	120	250
No-load driving torque at low travel speed	[Nm]	0.008	0.014	0.026	0.069
	[m/s]	0.05	0.05	0.05	0.05
No-load driving torque at maximum travel speed	[Nm]	0.029	0.042	0.1	0.306
	[m/s]	0.4	0.5	0.6	0.6
Max. radial force ¹⁾	[N]	30	75	180	230
Max. rotational speed	[rpm]	4000	3750	3600	3000
Max. acceleration	[m/s ²]	15			
Repetition accuracy	[mm]	±0.015			
Reversing backlash	[mm]	≤ 0.15			
Position sensing ²⁾		Magneto-resistive, inductive			

1) At the drive shaft

2) For sizes 45 and 60, only inductor sensing is possible as of a stroke of 100 mm

Operating and environmental conditions					
Size		25	32	45	60
Ambient temperature ¹⁾	[°C]	0 ... +50			
Degree of protection		IP40			
Duty cycle	[%]	100			
Maintenance interval		Life-time lubrication			

1) Note operating range of proximity sensors

Weight [g]					
Size		25	32	45	60
Basic weight with 0 mm stroke		176	331	608	1555
Additional weight per 10 mm stroke		19	30	63	95
Moving mass with 0 mm stroke		83	149	212	675
Moving mass per 10 mm stroke		9	12	30	40

Mini slides EGSC-BS

Technical data

Spindle					
Size		25	32	45	60
Diameter	[mm]	6	8	10	12
Pitch	[mm/ rev.]	6	8	10	12

Mass moment of inertia					
Size		25	32	45	60
J_0	[kg cm ²]	0.0014	0.0062	0.0136	0.0839
J_H per metre stroke	[kg cm ² /m]	0.0150	0.0493	0.1361	0.2708
J_L per kg payload	[kg cm ² /kg]	0.0091	0.0162	0.0253	0.0365

The mass moment of inertia J_{act} of the mini slide is calculated as follows: $J_{act} = J_0 + J_H/1000 \text{ mm} \times \text{working stroke}$

Homing

Homing can be carried out in two ways:

- Against a fixed stop
- Using a reference switch

The following values must be observed:

Size		25	32	45	60
Max. impact energy	[J]	0.005×10^{-3}	0.009×10^{-3}	0.014×10^{-3}	0.044×10^{-3}
At max. homing speed	[m/s]	0.01			

Materials

Sectional view

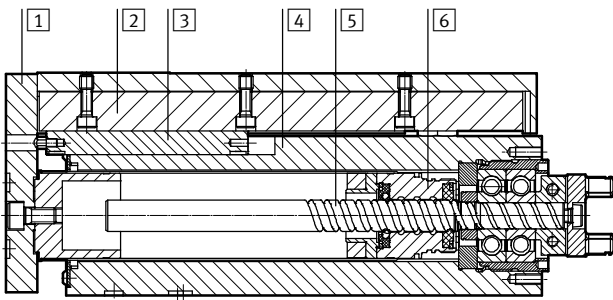

Axis		
1	Yoke plate	Anodised wrought aluminium alloy
2	Slides	Anodised wrought aluminium alloy
3	Guide rail	Steel
4	Housing	Anodised wrought aluminium alloy
5	Spindle	Steel
6	Spindle nut	Steel
Note on materials		RoHS-compliant
		Contains paint-wetting impairment substances

Mini slides EGSC-BS

Technical data

Dynamic characteristic load values

The indicated forces and torques refer to the centre of the guide.
These values must not be exceeded during dynamic operation.

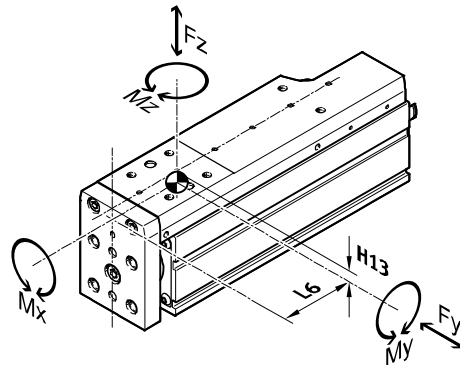

Distance from centre of guide		25	32	45	60
Size					
Dimension H13	[mm]	7.3	7.9	10.2	15.9
Dimension L6 ¹⁾	[mm]	25.1	31.8	37.3	53.4

1) The dimension relates to the retracted position of the slide. In the advanced position, the dimension must be extended accordingly.

Max. permissible forces and torques for the bearing calculation, for a service life of 5 x 10 ⁶ cycles and max. stroke					
Size		25	32	45	60
F _{y,max.}	[N]	669	991	1314	4937
F _{z,max.}	[N]	669	991	1314	4937
M _{x,max.}	[Nm]	2.0	3.4	8.1	20
M _{y,max.}	[Nm]	2.1	3.2	7	30
M _{z,max.}	[Nm]	2.1	3.2	7	30

 **Note**

For a guide system to have a service life of 5 x 10⁶ cycles, the load comparison factor must have a value of $f_v \leq 1$, based on the maximum permissible forces and torques for a service life of 5 x 10⁶ cycles.

This formula can be used to calculate a guide value.

The engineering software "PositioningDrives" is available for more precise calculations → www.festo.com

If the axis is subjected to two or more of the indicated forces and torques simultaneously, the following equation must be satisfied in addition to the indicated maximum loads:

Calculating the load comparison factor:

$$f_v = \frac{|F_{y,dyn}|}{F_{y,max}} + \frac{|F_{z,dyn}|}{F_{z,max}} + \frac{|M_{x,dyn}|}{M_{x,max}} + \frac{|M_{y,dyn}|}{M_{y,max}} + \frac{|M_{z,dyn}|}{M_{z,max}} \leq 1$$

Mini slides EGSC-BS

Technical data

Calculating the service life

The service life of the guide depends on the load. To be able to make a statement about the service life of the guide, the graph below plots the load comparison factor f_v against the service life.

These values are only theoretical. You must consult your local Festo contact for a load comparison factor f_v greater than 1.

Load comparison factor f_v as a function of service life l

Example:

A user wants to move an x kg load. Using the formula (→ page 12) gives a value of 1.5 for the load comparison factor f_v . According to the graph, the guide would have a service life of approx. 1.5×10^6 cycles. Reducing the acceleration reduces the M_y and M_z values. A load comparison factor f_v of 1 now gives a service life of 5×10^6 cycles.

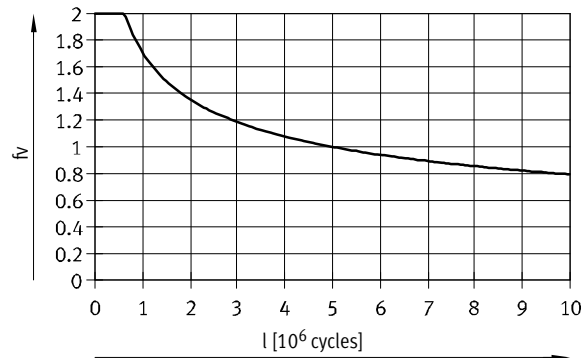

Comparison of the characteristic load values for 5×10^6 cycles with dynamic forces and torques of recirculating ball bearing guides

The characteristic load values of roller guides are standardised to ISO and JIS using dynamic and static forces and torques. These forces and torques are based on an expected service life of the guide system of 100 km to ISO or 50 km to JIS. As the characteristic load values are dependent on the service life, the maximum permissible forces and torques for a 5000 km service life cannot be compared with the dynamic forces and torques of roller guides to ISO/JIS.

To make it easier to compare the guide capacity of mini slides EGSC with roller guides, the table below lists the theoretically permissible forces and torques for a calculated service life of 100 km. This corresponds to the dynamic forces and torques to ISO.

These 100 km values have been calculated mathematically and are only to be used for comparing with dynamic forces and torques to ISO. The drives must not be loaded with these characteristic values as this could damage the axes.

Max. permissible forces and torques for a theoretical service life of 100 km (from a guide perspective only)

Application: Mass m on slide

Size	25	32	45	60
$F_{y_{max}}$ [N]	1310	2135	3240	13400
$F_{z_{max}}$ [N]	1310	2135	3240	13400
$M_{x_{max}}$ [Nm]	5	10	20	107
$M_{y_{max}}$ [Nm]	4	7	17	117
$M_{z_{max}}$ [Nm]	4	7	17	117

Mini slides EGSC-BS

Technical data

Speed v as a function of stroke l

Size 25

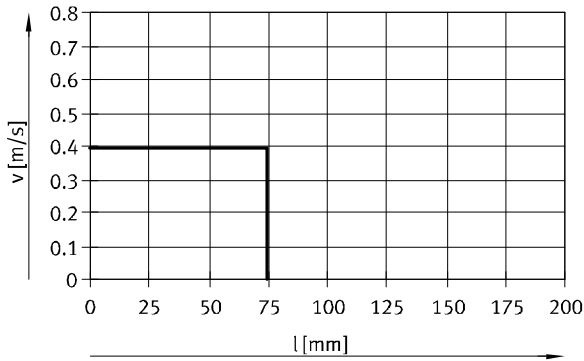

Size 32

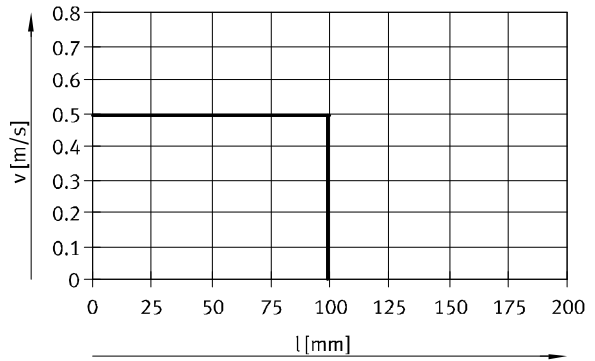

Size 45

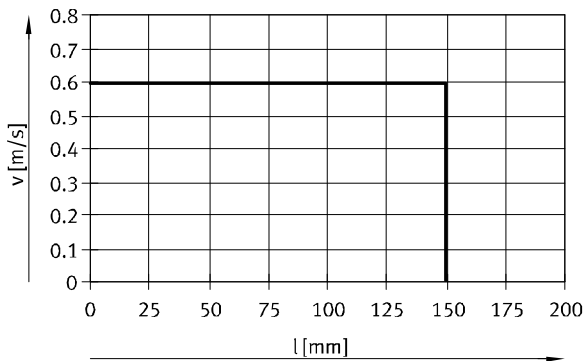

Size 60

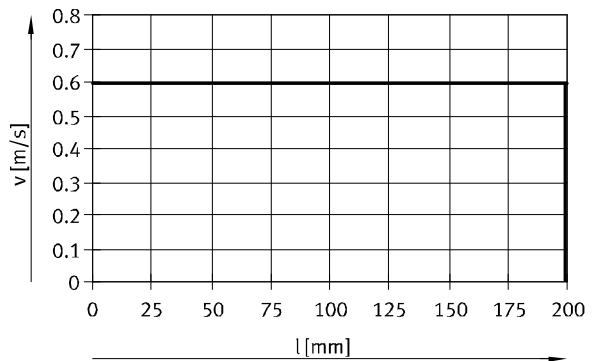

Feed force F as a function of input torque M

Size 25/32

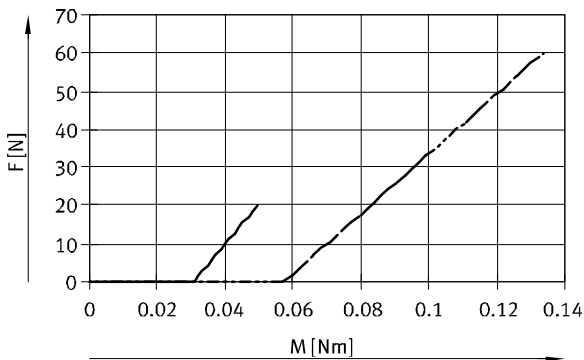

Size 45/60

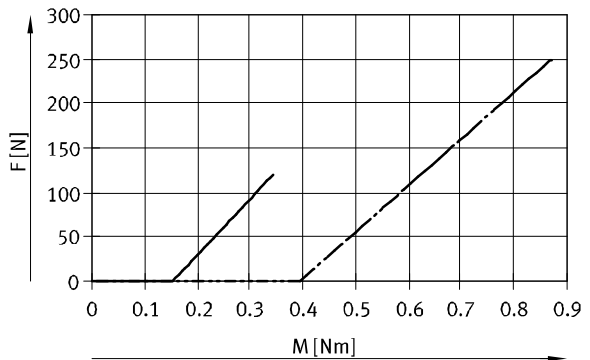

— EGSC-BS-KF-25
 - - - EGSC-BS-KF-32

— EGSC-BS-KF-45
 - - - EGSC-BS-KF-60

Mini slides EGSC-BS

Technical data

Feed force F as a function of service life l

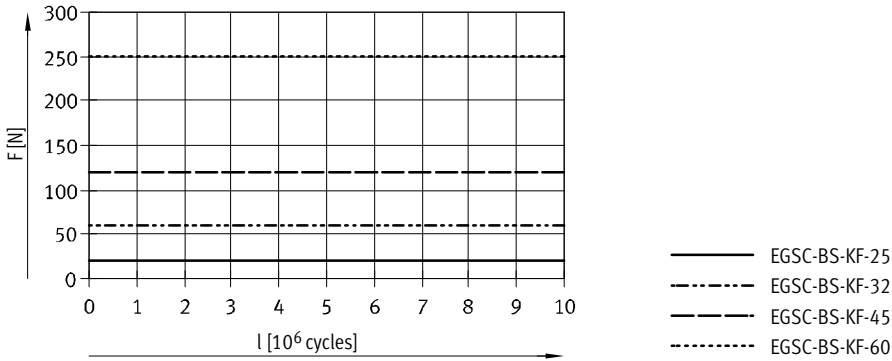

Deflection f of the guide rail as a function of stroke l



Fy/Fz at which the characteristic curves were determined

EGSC-BS-KF-25: 10 N EGSC-BS-KF-45: 10 N
 EGSC-BS-KF-32: 10 N EGSC-BS-KF-60: 10 N

Deflection fy

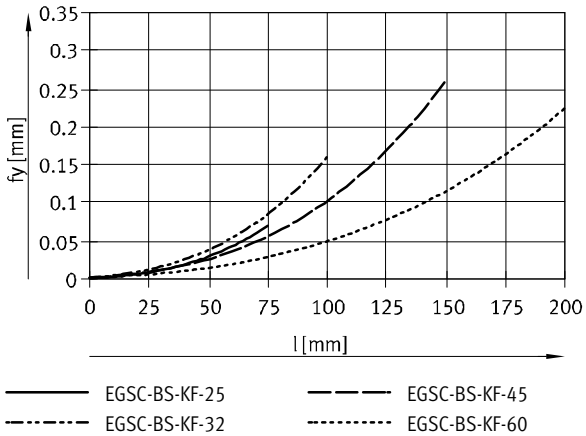

Deflection fz

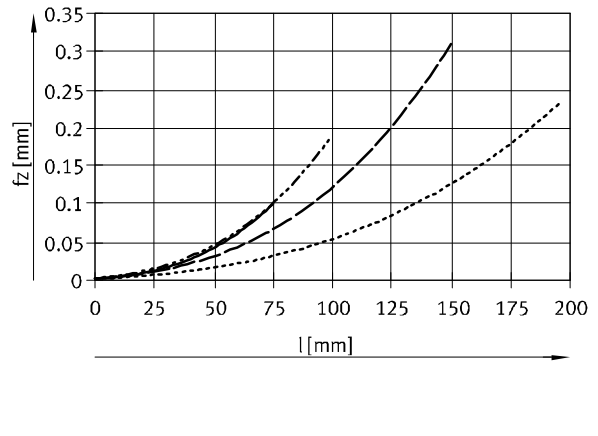

Mini slides EGSC-BS

Technical data

Dimensions

Download CAD data → www.festo.com

Size 25/32/45

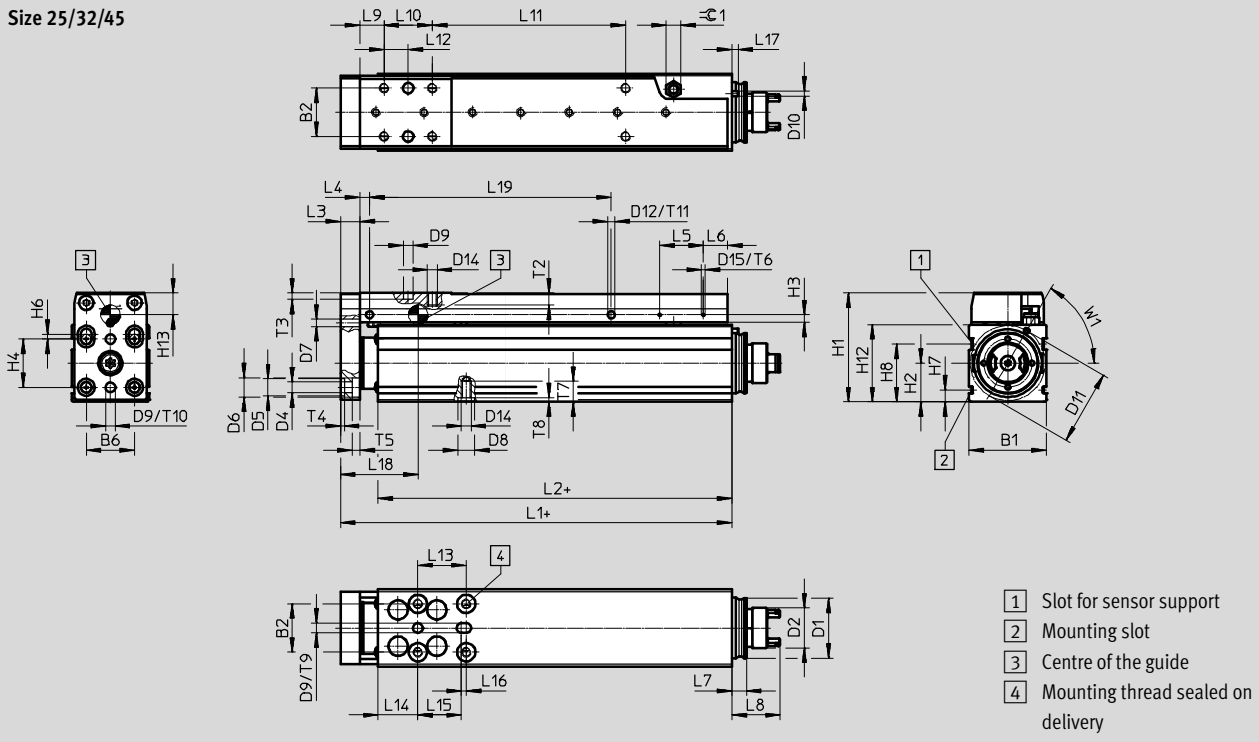

Size: 60

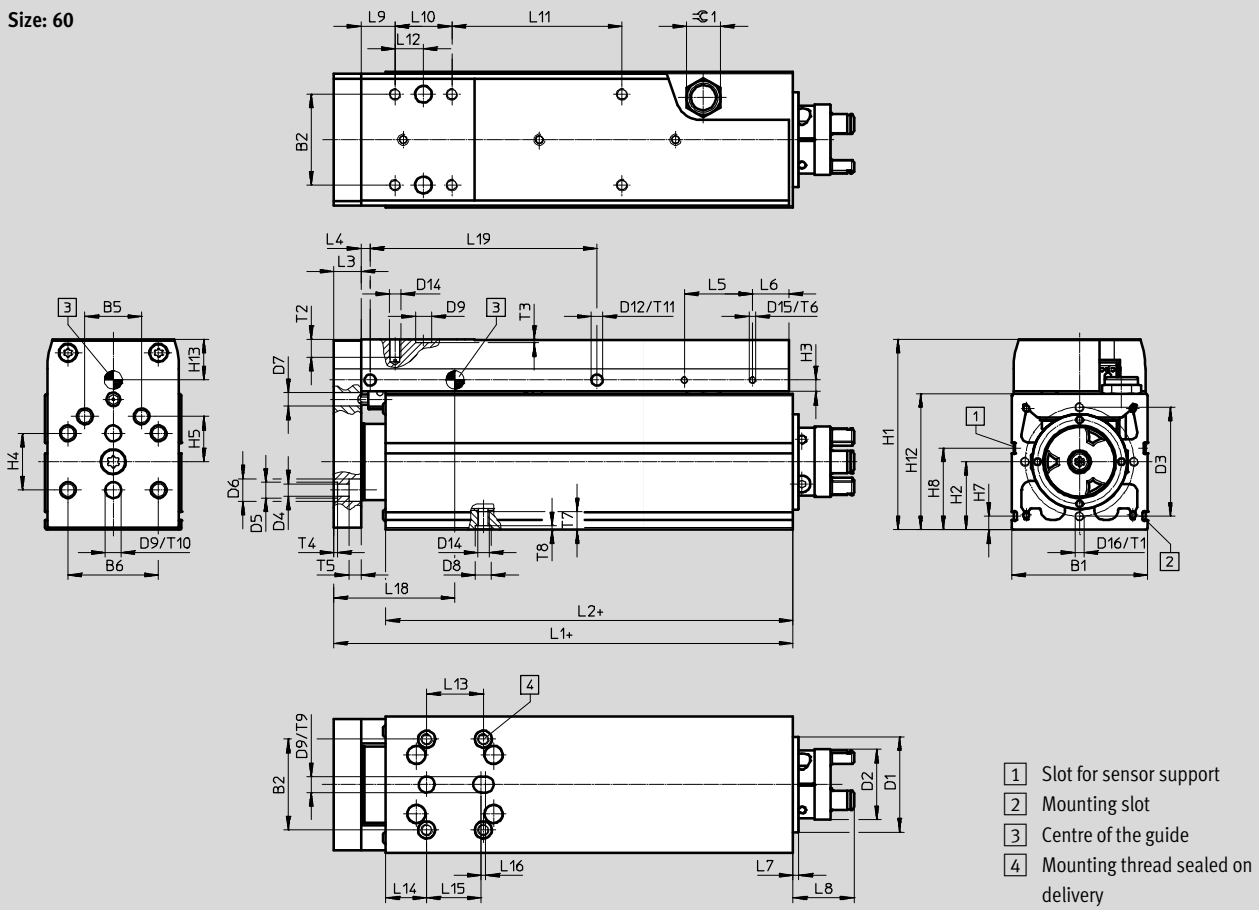

Mini slides EGSC-BS

FESTO

Technical data

Size	B1 ±0.15	B2	B5	B6	D1 ∅	D2 ∅	D3 ∅	D4 ∅ H13	D5 ∅ H7	D6 ∅ H13	D7 ∅	D8 ∅ H7	D9 ∅ H8	D10 ∅	D11 ∅
25	25	17	–	17	20.5	11	–	3.4	5	6	2.5	5	2	2	25
32	32	20	–	20	25	16.5	–	4.5	7	8	3	7	4	2	31
45	45	25	–	25	32	16.5	–	5.5	7	10	3	7	5	3	41
60	60	40	25	40	42	31	48	5.5	7	10	6	7	7	–	–

Size	D12 ∅	D13	D14	D15	D16	H1	H2	H3	H4	H5	H6	H7	H8	H12 ±0.15	H13
25	3	–	M3	M1.6	–	36.5	12.5	2.5	17	–	–	4.9	20.5	25	7.6
32	3	–	M4	M1.6	–	45	16	3	20	–	2	4.9	24	32	8.4
45	3	–	M5	M2	–	60.5	22.5	3	25	–	–	6.1	28.5	45	10.7
60	5	M4	M5	M3	M4	84	30	5	25	20	–	6.1	36	60	16.4

Size	L1	L2	L3 +0.2	L4	L5 ±0.1	L6	L7	L8	L9	L10	L12	L13	L14	L15	L16
25	53.6	42	6	4	18	6	5	15	10	17	8.5	17	13.5	16.5	1
32	62	46.5	8	4	18	10	6	19.9	10	20	10	20	16.5	18	2
45	73.8	54.5	10	4	24	12	6	19.9	15	25	12.5	25	17.5	24	2
60	102.4	79.5	12	4	30	16	2.5	26.9	15	25	12.5	25	30	24	2

Size	L17	L18	T1	T2	T3 +0.1	T4 +0.1	T5	T6	T7	T8 +0.1	T9 +0.1	T10 +0.1	T11 –0.2	W1	∠ 1
25	2.5	25.1	–	4.5	2.6	1.3	3.2	2	6	1.3	2.1	3.1	2	60°	6
32	2.5	31.8	–	5	2.6	1.6	3.2	1.5	8.5	1.8	2.6	2.6	1.5	60°	6
45	2	37.3	–	6	1.3	1.6	5.4	4	7	1.8	1.3	1.3	5	60°	12
60	–	53.4	10	8	1.6	1.6	5.4	6	8	1.8	1.6	1.6	5	–	15

Size	Stroke [mm]	L19	L11
25	25	25	0
	50	50	33
	75	75	58
32	25	25	0
	50	50	30
	75	75	55
	100	100	80
45	25	25	0
	50	50	25
	75	75	50
	100	100	75
	125	125	100
	150	150	125
60	50	50	25
	75	75	50
	100	100	75
	125	125	100
	150	150	125
	200	200	175

Mini slides EGSC-BS

Technical data

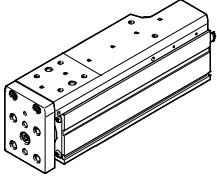
Ordering data					
	Size	Spindle pitch	Stroke	Part No.	Type
	25	6	25	8048310	EGSC-BS-KF-25-25-6P
			50	8048311	EGSC-BS-KF-25-50-6P
			75	8061280	EGSC-BS-KF-25-75-6P
	32	8	25	8048306	EGSC-BS-KF-32-25-8P
			50	8048307	EGSC-BS-KF-32-50-8P
			75	8048308	EGSC-BS-KF-32-75-8P
			100	4356032	EGSC-BS-KF-32-100-8P
	45	10	25	8048300	EGSC-BS-KF-45-25-10P
			50	8048301	EGSC-BS-KF-45-50-10P
			75	8048302	EGSC-BS-KF-45-75-10P
			100	4022926	EGSC-BS-KF-45-100-10P
			125	8048303	EGSC-BS-KF-45-125-10P
			150	8048304	EGSC-BS-KF-45-150-10P
	60	12	50	8048362	EGSC-BS-KF-60-50-12P
			75	8048363	EGSC-BS-KF-60-75-12P
			100	4356469	EGSC-BS-KF-60-100-12P
			125	8048364	EGSC-BS-KF-60-125-12P
			150	8048365	EGSC-BS-KF-60-150-12P
200			8048366	EGSC-BS-KF-60-200-12P	

Mini slides EGSC-BS

Accessories



Note

Depending on the combination of motor and drive, it may not be possible to reach the maximum feed force of the drive.

When using parallel kits, the no-load driving torque of the respective kit must be taken into consideration.

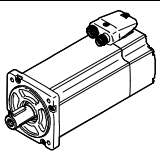
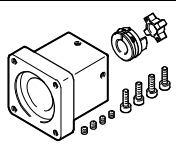
Permissible axis/motor combinations with axial kit – Without gear unit		Technical data → Internet: eamm-a	
Motor ¹⁾	Axial kit		
Type	Part No.	Type	
			
EGSC-25			
With stepper motor			
EMMS-ST-28-...	4505258	EAMM-A-V20-28A	
EGSC-32			
With servo motor			
EMME-AS-40-...	4491059	EAMM-A-V25-40P	
With stepper motor			
EMMS-ST-42-...	4582608	EAMM-A-V25-42A	
EGSC-45			
With servo motor			
EMME-AS-40-...	4595742	EAMM-A-V32-40P	
EMME-AS-60-...	4608750	EAMM-A-V32-60P	
With stepper motor			
EMMS-ST-42-...	4281142	EAMM-A-V32-42A	
EMMS-ST-57-...	4597016	EAMM-A-V32-57A	
EGSC-60			
With servo motor			
EMME-AS-60-...	4133487	EAMM-A-T42-60P	
EMME-AS-80-...	4623788	EAMM-A-T42-80P	
With stepper motor			
EMMS-ST-57-...	4327034	EAMM-A-T42-57A	
EMMS-ST-87-...	4610008	EAMM-A-T42-87A	

1) The input torque must not exceed the maximum permissible transferable torque of the axial kit.

Mini slides EGSC-BS

Accessories

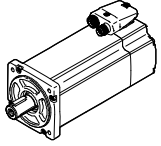
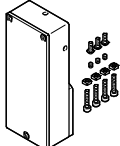
Permissible axis/motor combinations with parallel kit		Technical data → Internet: eamm-u	
Motor/gear unit ¹⁾	Parallel kit		
		<ul style="list-style-type: none"> • The kit can be mounted in all directions • Use in combination with third-party motors on request 	
Type	Part No.	Type	
EGSC-25			
With stepper motor			
EMMS-ST-28-...	4767125	EAMM-U-30-V20-28A-44	
EGSC-32			
With servo motor			
EMME-AS-40-...	4782056	EAMM-U-45-V25-40P-63	
With stepper motor			
EMMS-ST-42-...	4825645	EAMM-U-45-V25-42A-63	
EGSC-45			
With servo motor			
EMME-AS-40-...	4718297	EAMM-U-45-V32-40P-63	
With stepper motor			
EMMS-ST-42-...	4280674	EAMM-U-45-V32-42A-63	
EGSC-60			
With servo motor			
EMMS-AS-55-...	8092868	EAMM-U-65-T42-55A-87	
EMME-AS-60-...	4784301	EAMM-U-65-T42-60P-87	
With stepper motor			
EMMS-ST-57-...	4331535	EAMM-U-65-T42-57A-87	

1) The input torque must not exceed the maximum permissible transferable torque of the parallel kit.

Mini slides EGSC-BS

Accessories

Profile mounting EAHF-L2-...-P-S

Materials:

Anodised wrought aluminium alloy

RoHS-compliant

- For mounting the slide on the side of the profile

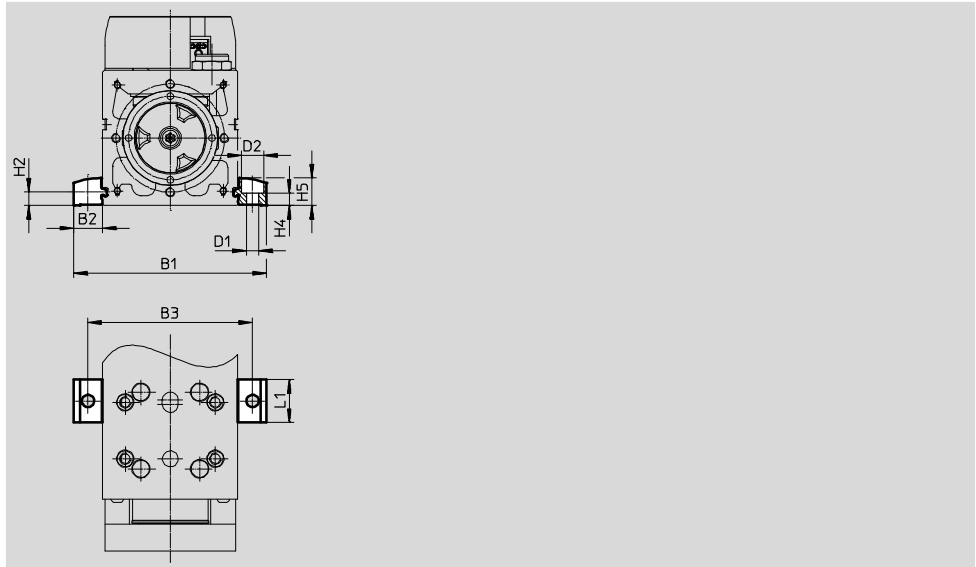
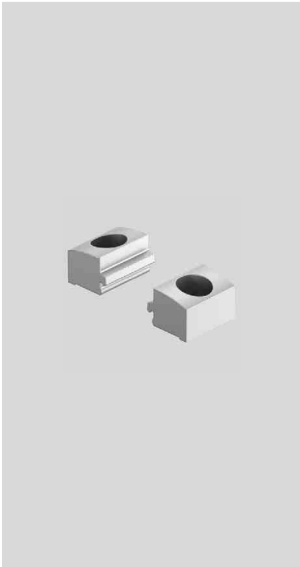

Dimensions and ordering data						
For size	B1	B2	B3	D1 ∅ H13	D2 ∅ H13	H2
25	44.4	9.7	35	4.5	8	4.9
32	51.4	9.7	42	4.5	8	4.9
45	70.6	12.8	58	5.5	10	6.1
60	85.6	12.8	73	5.5	10	6.1

For size	H4 ±0.1	H5	L1	Weight [g]	Part No.	Type
25	4.2	9	19	4	5183153	EAHF-L2-25-P-S
32	4.2	9	19	4	5183153	EAHF-L2-25-P-S
45	5.5	12.2	19	6	5184133	EAHF-L2-45-P-S
60	5.5	12.2	19	6	5184133	EAHF-L2-45-P-S

Mini slides EGSC-BS

Accessories

Profile mounting EAHF-L2-...-P:

Materials:

Anodised wrought aluminium alloy

RoHS-compliant

- For mounting the slide on the side of the profile.

The profile mounting can be fixed in place on the mounting surface using the drill hole in the centre

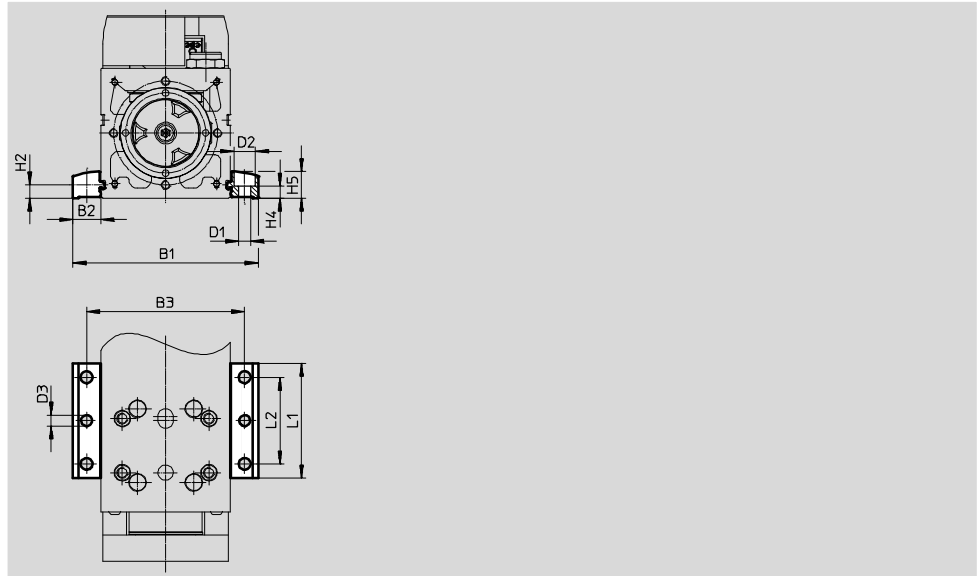

Dimensions and ordering data							
For size	B1	B2	B3	D1 ∅ H13	D2 ∅ H13	D3 ∅	H2
25	44.4	9.7	35	4.5	8	4	4.9
32	51.4	9.7	42	4.5	8	4	4.9
45	70.6	12.8	58	5.5	10	5	6.1
60	85.6	12.8	73	5.5	10	5	6.1

For size	H4 ±0.1	H5	L1	L2	Weight [g]	Part No.	Type
25	4.2	9	53	40	19	4835684	EAHF-L2-25-P
32	4.2	9	53	40	19	4835684	EAHF-L2-25-P
45	5.5	12.2	53	40	35	4835728	EAHF-L2-45-P
60	5.5	12.2	53	40	35	4835728	EAHF-L2-45-P

Mini slides EGSC-BS

Accessories

Switch lug EAPM-...-SLS

For sensing using inductive proximity sensors SIES-8M

Materials:

Galvanised steel

RoHS-compliant

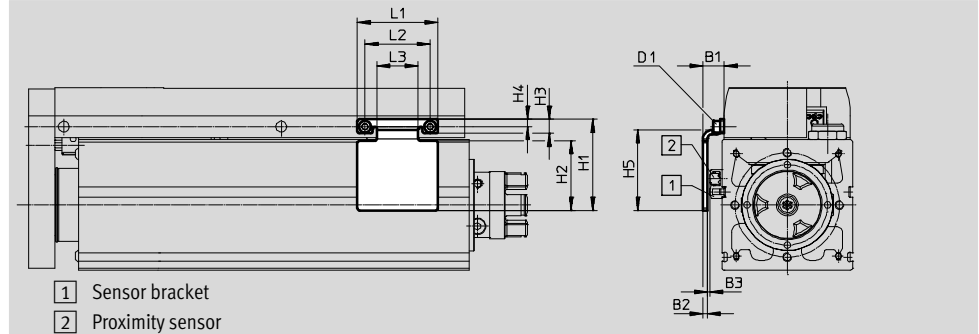

Dimensions and ordering data								
For size	B1	B2	B3	D1	H1	H2	H3	H4
25	9.2	2	1.0 ±0.32	M1.6	21	13	4.3	2.5
32	9.2	2	1.0 ±0.26	M1.6	27	19	4.3	2.5
45	9.4	2	0.7 ±0.26	M2	37	28	5.5	3.3
60	9.7	2	0.7 ±0.31	M3	42	32	6.6	3.5

For size	H5	L1	L2	L3	Weight [g]	Part No.	Type
25	18	22	18	10	8	8067258	EAPM-E19-25-SLS
32	24	22	18	10	10	8067259	EAPM-L2-32-SLS
45	33	30	24	14	18	8067260	EAPM-L2-45-SLS
60	37	37	30	19	27	8067261	EAPM-L2-60-SLS

Sensor bracket EAPM-L2

Materials:

Anodised wrought aluminium alloy

RoHS-compliant

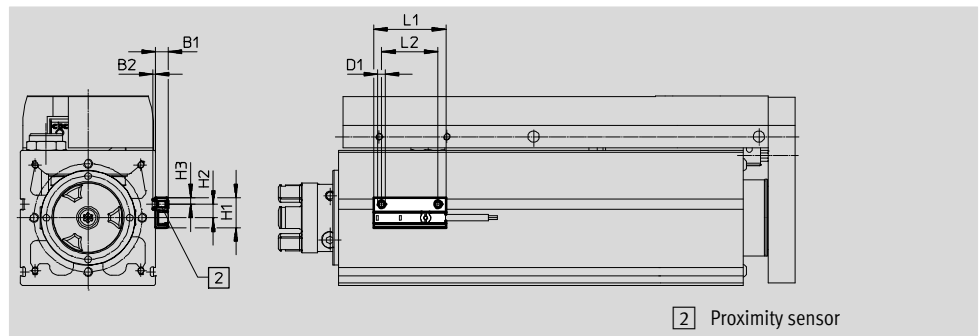

Dimensions and ordering data					
For size	B1	B2	D1	H1	H2
25, 32, 45, 60	5.5	1.3	M4	13.4	6

For size	H3	L1	L2	Weight [g]	Part No.	Type
25, 32, 45, 60	3	32	25	4	4759852	EAPM-L2-SH

Mini slides EGSC-BS

Accessories



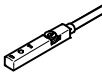
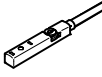

Ordering data – Centring sleeve					
	For size	Description	Part No.	Type	PU ¹⁾
	25	For slide and yoke plate	150928	ZBS-5	10
	32, 45, 60		186717	ZBH-7	

1) Packaging unit quantity

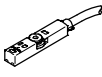
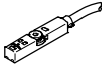
Ordering data – Proximity sensors for T-slot, inductive						Technical data → Internet: sies
	Type of mounting	Switching output	Electrical connection	Cable length [m]	Part No.	Type
N/O contact						
	Inserted in the slot from above, flush with the cylinder profile	PNP	Cable, 3-wire	7.5	551386	SIES-8M-PS-24V-K-7,5-OE
			Plug connector M8x1, 3-pin	0.3	551387	SIES-8M-PS-24V-K-0,3-M8D
		NPN	Cable, 3-wire	7.5	551396	SIES-8M-NS-24V-K-7,5-OE
			Plug connector M8x1, 3-pin	0.3	551397	SIES-8M-NS-24V-K-0,3-M8D
N/C contact						
	Inserted in the slot from above, flush with the cylinder profile	PNP	Cable, 3-wire	7.5	551391	SIES-8M-PO-24V-K-7,5-OE
			Plug connector M8x1, 3-pin	0.3	551392	SIES-8M-PO-24V-K-0,3-M8D
		NPN	Cable, 3-wire	7.5	551401	SIES-8M-NO-24V-K-7,5-OE
			Plug connector M8x1, 3-pin	0.3	551402	SIES-8M-NO-24V-K-0,3-M8D

Ordering data – Proximity sensor for T-slot, magneto-resistive						Technical data → Internet: smt
	Type of mounting	Switching output	Electrical connection	Cable length [m]	Part No.	Type
N/O contact						
	Inserted in the slot from above, flush with the cylinder profile, short design	PNP	Cable, 3-wire	2.5	574335	SMT-8M-A-PS-24V-E-2,5-OE
			Plug connector M8x1, 3-pin	0.3	574334	SMT-8M-A-PS-24V-E-0,3-M8D
N/C						
	Inserted in the slot from above, flush with the cylinder profile, short design	PNP	Cable, 3-wire	7.5	574340	SMT-8M-A-PO-24V-E-7,5-OE

Ordering data – Connecting cables						Technical data → Internet: nebu
	Electrical connection, left	Electrical connection, right	Cable length [m]	Part No.	Type	
	Straight socket, M8x1, 3-pin	Cable, open end, 3-wire	2.5	541333	NEBU-M8G3-K-2.5-LE3	
			5	541334	NEBU-M8G3-K-5-LE3	
	Angled socket, M8x1, 3-pin	Cable, open end, 3-wire	2.5	541338	NEBU-M8W3-K-2.5-LE3	
			5	541341	NEBU-M8W3-K-5-LE3	

 Note

For sizes 45 and 60, inductive proximity sensor SIES-8M must be used for strokes greater than 100 mm.

Festo - Your Partner in Automation



1 Festo Inc.
5300 Explorer Drive
Mississauga, ON L4W 5G4
Canada

Festo Customer Interaction Center
Tel: 1 877 463 3786
Fax: 1 877 393 3786
Email: customer.service.ca@festo.com

2 Festo Pneumatic
Av. Ceylán 3,
Col. Tequesquináhuac
54020 Tlalnepantla,
Estado de México

Multinational Contact Center
01 800 337 8669
ventas.mexico@festo.com

3 Festo Corporation
1377 Motor Parkway
Suite 310
Islandia, NY 11749

Festo Customer Interaction Center
1 800 993 3786
1 800 963 3786
customer.service.us@festo.com

4 Regional Service Center
7777 Columbia Road
Mason, OH 45040

Connect with us



www.festo.com/socialmedia



www.festo.com

Subject to change