

**Toothed belt axes EGC-HD-TB, with heavy-duty guide**

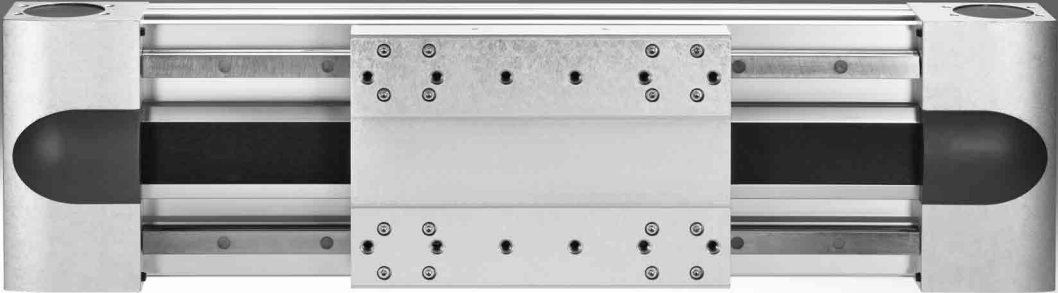

# Electromechanical drives

Selection aid



## Overview of toothed belt and spindle axes

### Toothed belt axes

- Speeds of up to 10 m/s
- Acceleration of up to 50 m/s<sup>2</sup>
- Repetition accuracy of up to ±0.08 mm
- Strokes of up to 8500 mm (longer strokes on request)
- Flexible motor mounting

### Spindle axes

- Speeds of up to 2 m/s
- Acceleration of up to 20 m/s<sup>2</sup>
- Repetition accuracy of up to ±0.003 mm
- Strokes of up to 3000 mm

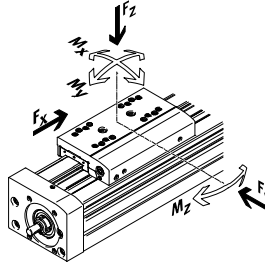

## Toothed belt axes

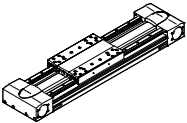
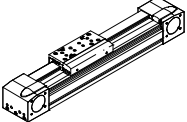
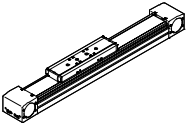
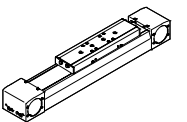
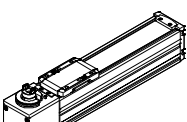
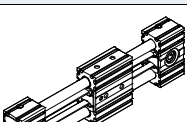
Type	$F_x$ [N]	$v$ [m/s]	$M_x$ [Nm]	$M_y$ [Nm]	$M_z$ [Nm]	Key features
<b>Heavy-duty recirculating ball bearing guide</b>						
<b>EGC-HD-TB</b>						
	450 1000 1800	3 5 5	140 300 900	275 500 1450	275 500 1450	<ul style="list-style-type: none"> <li>• Flat drive unit with rigid, closed profile</li> <li>• Precision DUO guide rail with high load capacity</li> <li>• Ideal as a basic axis for linear gantries and cantilever axes</li> </ul>
<b>Recirculating ball bearing guide</b>						
<b>EGC-TB-KF</b>						
	50 100 350 800 2500	3 5 5 5 5	3.5 16 36 144 529	10 132 228 680 1820	10 132 228 680 1820	<ul style="list-style-type: none"> <li>• Rigid, closed profile</li> <li>• Precision guide rail with high load capacity</li> <li>• Small drive pinions reduce required driving torque</li> <li>• Space-saving position sensing</li> </ul>
<b>ELGA-TB-KF</b>						
	350 800 1300 2000	5 5 5 5	16 36 104 167	132 228 680 1150	132 228 680 1150	<ul style="list-style-type: none"> <li>• Internal guide and toothed belt</li> <li>• Precision guide rail with high load capacity</li> <li>• Guide and toothed belt protected by cover strip</li> <li>• High feed forces</li> </ul>
<b>ELGA-TB-KF-F1</b>						
	260 600 1000	5 5 5	16 36 104	132 228 680	132 228 680	<ul style="list-style-type: none"> <li>• Suitable for use in the food zone</li> <li>• "Clean Look": smooth, easy to clean surfaces</li> <li>• Internal guide and toothed belt</li> <li>• Precision guide rail with high load capacity</li> <li>• Guide and toothed belt protected by cover strip</li> </ul>
<b>ELGC-TB-KF</b>						
	75 120 250	1.2 1.5 1.5	5.5 29.1 59.8	4.7 31.8 56.2	4.7 31.8 56.2	<ul style="list-style-type: none"> <li>• Internal guide and toothed belt</li> <li>• Precision guide rail with high load capacity</li> <li>• Guide and toothed belt protected by cover strip</li> </ul>
<b>ELGR-TB</b>						
	50 100 350	3 3 3	2.5 5 15	20 40 124	20 40 124	<ul style="list-style-type: none"> <li>• Cost-optimised rod guide</li> <li>• Ready-to-install unit</li> <li>• Ball bearings with high load capacity for dynamic operation</li> </ul>

# Electromechanical drives

Selection aid

## Overview of toothed belt and spindle axes

### Toothed belt axes

- Speeds of up to 10 m/s
- Acceleration of up to 50 m/s<sup>2</sup>
- Repetition accuracy of up to ±0.08 mm
- Strokes of up to 8500 mm (longer strokes on request)
- Flexible motor mounting

### Spindle axes

- Speeds of up to 2 m/s
- Acceleration of up to 20 m/s<sup>2</sup>
- Repetition accuracy of up to ±0.003 mm
- Strokes of up to 3000 mm

### Coordinate system

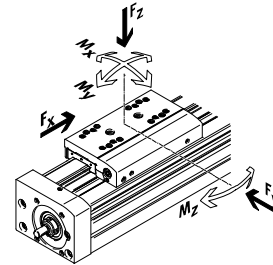

## Toothed belt axes

Type	$F_x$ [N]	$v$ [m/s]	$M_x$ [Nm]	$M_y$ [Nm]	$M_z$ [Nm]	Key features
<b>Roller bearing guide</b>						
ELGA-TB-RF						
	350	10	11	40	40	<ul style="list-style-type: none"> <li>• Heavy-duty roller bearing guide</li> <li>• Guide and toothed belt protected by cover strip</li> <li>• Speeds of up to 10 m/s</li> <li>• Lower weight than axes with guide rails</li> </ul>
	800	10	30	180	180	
	1300	10	100	640	640	
ELGA-TB-RF-F1						
	260	10	8.8	32	32	<ul style="list-style-type: none"> <li>• Suitable for use in the food zone</li> <li>• "Clean Look": smooth, easy to clean surfaces</li> <li>• Heavy-duty roller bearing guide</li> <li>• Guide and toothed belt protected by cover strip</li> <li>• Lower weight than axes with guide rails</li> </ul>
	600	10	24	144	144	
	1000	10	80	512	512	
<b>Plain-bearing guide</b>						
ELGA-TB-G						
	350	5	5	30	10	<ul style="list-style-type: none"> <li>• Guide and toothed belt protected by cover strip</li> <li>• For simple handling tasks</li> <li>• As a drive component for external guides</li> <li>• Insensitive to harsh operating conditions</li> </ul>
	800	5	10	60	20	
	1300	5	120	120	40	
ELGR-TB-GF						
	50	1	1	10	10	<ul style="list-style-type: none"> <li>• Cost-optimised rod guide</li> <li>• Ready-to-install unit</li> <li>• Heavy-duty plain bearings for use in harsh operating conditions</li> </ul>
	100	1	2.5	20	20	
	350	1	1	40	40	

# Electromechanical drives

Selection aid

## Overview of toothed belt and spindle axes

Toothed belt axes	Spindle axes	Coordinate system
<ul style="list-style-type: none"> <li>• Speeds of up to 10 m/s</li> <li>• Acceleration of up to 50 m/s<sup>2</sup></li> <li>• Repetition accuracy of up to ±0.08 mm</li> <li>• Strokes of up to 8500 mm (longer strokes on request)</li> <li>• Flexible motor mounting</li> </ul>	<ul style="list-style-type: none"> <li>• Speeds of up to 2 m/s</li> <li>• Acceleration of up to 20 m/s<sup>2</sup></li> <li>• Repetition accuracy of up to ±0.003 mm</li> <li>• Strokes of up to 3000 mm</li> </ul>	

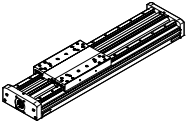
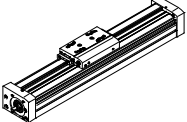
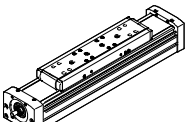
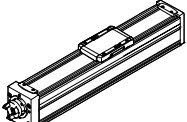
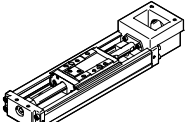
Spindle axes						
Type	$F_x$ [N]	$v$ [m/s]	$M_x$ [Nm]	$M_y$ [Nm]	$M_z$ [Nm]	Key features
<b>Heavy-duty recirculating ball bearing guide</b>						
EGC-HD-BS						
	300 600 1300	0.5 1.0 1.5	140 300 900	275 500 1450	275 500 1450	<ul style="list-style-type: none"> <li>• Flat drive unit with rigid, closed profile</li> <li>• Precision DUO guide rail with high load capacity</li> <li>• Ideal as a basic axis for linear gantries and cantilever axes</li> </ul>
<b>Recirculating ball bearing guide</b>						
EGC-BS-KF						
	300 600 1300 3000	0.5 1.0 1.5 2.0	16 36 144 529	132 228 680 1820	132 228 680 1820	<ul style="list-style-type: none"> <li>• Rigid, closed profile</li> <li>• Precision guide rail with high load capacity</li> <li>• For the highest requirements in terms of feed force and accuracy</li> <li>• Space-saving position sensing</li> </ul>
ELGA-BS-KF						
	300 600 1300 3000	0.5 1.0 1.5 2.0	16 36 104 167	132 228 680 1150	132 228 680 1150	<ul style="list-style-type: none"> <li>• Internal guide and ball screw</li> <li>• Precision guide rail with high load capacity</li> <li>• For the highest requirements in terms of feed force and accuracy</li> <li>• Guide and ball screw protected by cover strip</li> <li>• Space-saving position sensing</li> </ul>
ELGC-BS-KF						
	40 100 200 350	0.6 0.6 0.8 1.0	1.3 5.5 29.1 59.8	1.1 4.7 31.8 56.2	1.1 4.7 31.8 56.2	<ul style="list-style-type: none"> <li>• Internal guide and ball screw</li> <li>• Guide and ball screw protected by cover strip</li> <li>• Space-saving position sensing</li> </ul>
EGSK						
	57 133 184 239 392	0.33 1.10 0.83 1.10 1.48	13 28.7 60 79.5 231	3.7 9.2 20.4 26 77.3	3.7 9.2 20.4 26 77.3	<ul style="list-style-type: none"> <li>• Spindle axes with maximum precision, compactness and rigidity</li> <li>• Recirculating ball bearing guide and ball screw without caged ball bearings</li> <li>• Standard designs in stock</li> </ul>

# Toothed belt axes EGC-HD-TB, with heavy-duty guide

## Key features

### At a glance

- New heavy-duty guide for:
  - Maximum loads and torques
  - High feed forces and speeds
  - Long service life
- Precision, resilient DUO guide rail
- Ideal as a basic axis for linear gantries and cantilever axes
- In addition to its technical data, the toothed belt axis also offers an excellent price/performance ratio
- Space-saving position sensing with proximity sensor in the profile slot
- Wide range of options for mounting on drives

### Flexible motor mounting

The motor position can be freely selected on four sides and can be changed at any time.

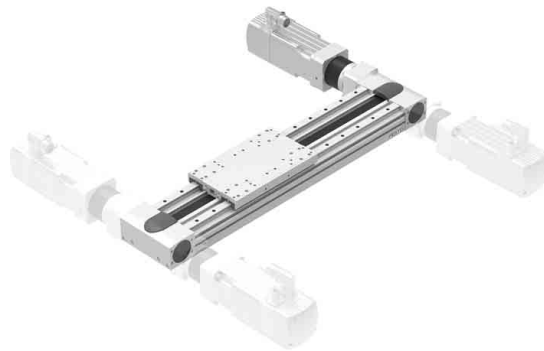

### Flat unit with rigid, closed profile

EGC-HD-125

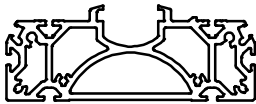

EGC-HD-160

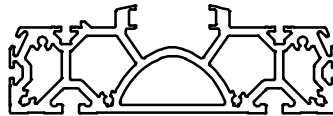

EGC-HD-220

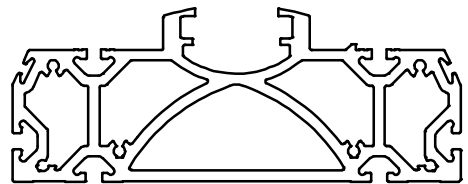

### Characteristic values of the axes

The specifications shown in the table are maximum values.

The precise values for each of the variants can be found in the relevant technical data section.

Version	Size	Working stroke [mm]	Speed [m/s]	Repetition accuracy [mm]	Feed force [N]	Guide characteristics				
						Forces and torques				
						Fy [N]	Fz [N]	Mx [Nm]	My [Nm]	Mz [Nm]
Recirculating ball bearing guide										
	125	50 ... 3000	3	+0.08	450	3650	3650	140	275	275
	160	50 ... 5000	5	+0.08	1000	5600	5600	300	500	500
	220	50 ... 4750	5	+0.1	1800	13000	13000	900	1450	1450

- - Note

PositioningDrives  
sizing software  
[www.festo.com](http://www.festo.com)

# Toothed belt axes EGC-HD-TB, with heavy-duty guide

Key features

## Slide variants

Standard slide

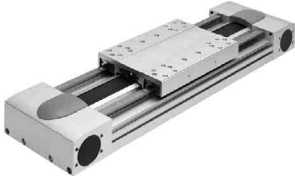

Standard slide, protected

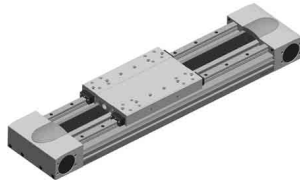

With additional slide

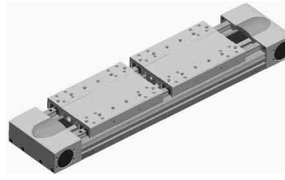

## Complete system comprising toothed belt axis, motor, motor controller and motor mounting kit

Toothed belt axis with recirculating ball bearing guide



## Motor

→ page 24



- 1 Servo motor EMME-AS, EMMS-AS
- 2 Gear unit EMGA

 Note

A range of specially adapted complete solutions is available for the toothed belt axis EGC and the motors.

## Motor controller

Technical data → Internet: motorcontroller



Servo motor controller  
CMMP-AS

## Motor mounting kit

→ page 24

### Axial kit

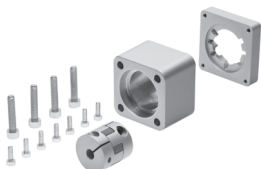

Kit comprising:

- Motor flange
- Coupling housing
- Coupling
- Screws

# Toothed belt axes EGC-HD-TB, with heavy-duty guide

Type codes

	EGC	-	HD	-	125	-	500	-	TB	-	50H	-	GK
<b>Type</b>													
EGC	Toothed belt axis												
<b>Guide</b>													
HD	Heavy-duty guide												
<b>Size</b>													
<b>Stroke [mm]</b>													
<b>Drive function</b>													
TB	Toothed belt												
<b>Stroke reserve</b>													
<b>Slide</b>													
GK	Standard slide												
GP	Standard slide, protected												

→		-		ZUB	-	2MX2Z	-	DN
<b>Additional slide</b>								
KL	Standard, left							
<b>Additional slide</b>								
KR	Standard, right							
<b>Accessories enclosed separately</b>								
...M	Profile mounting							
...B	Mounting slot cover							
...S	Sensor slot cover							
...Y	Slot nut for mounting slot							
...X	Proximity sensor (SIES), inductive, slot type 8, PNP, N/O contact, 7.5 m cable							
...Z	Proximity sensor (SIES), inductive, slot type 8, PNP, N/C contact, 7.5 m cable							
...A	Emergency buffer with retainer							
...C	Shock absorber with retainer							
...O	Proximity sensor (SIEN), inductive, M8, PNP, N/O contact, 2.5 m cable							
...P	Proximity sensor (SIEN), inductive, M8, PNP, N/C contact, 2.5 m cable							
...W	Proximity sensor (SIEN), inductive, M8, PNP, N/O contact, plug M8							
...R	Proximity sensor (SIEN), inductive, M8, PNP, N/C contact, plug M8							
...V	Connecting cable							
...CL	Cable clip							
<b>Operating instructions</b>								
DN	None							

# Toothed belt axes EGC-HD-TB, with heavy-duty guide

Peripherals overview

FESTO

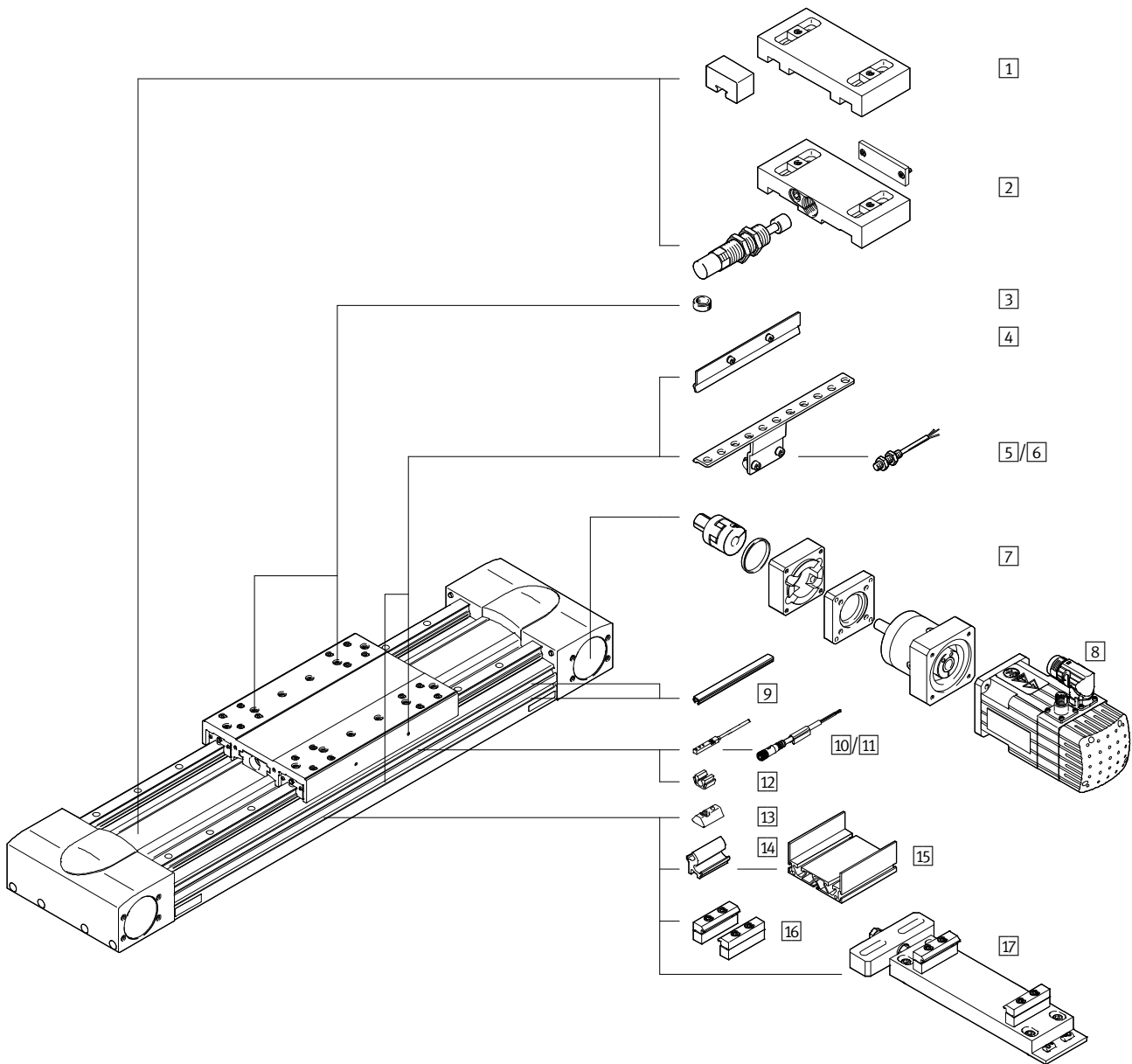

# Toothed belt axes EGC-HD-TB, with heavy-duty guide

Peripherals overview

Variants and accessories		
Type	Description	→ Page/Internet
1 Emergency buffer with retainer A	For avoiding damage at the end stop in the event of malfunction	27
2 Shock absorber with retainer C	For avoiding damage at the end stop in the event of malfunction	27
3 Centring pin/sleeve ZBS, ZBH	<ul style="list-style-type: none"> <li>For centring loads and attachments on the slide</li> <li>– Included in the scope of delivery:                             <ul style="list-style-type: none"> <li>For size 125: 2x ZBS-5, 2x ZBH-9</li> <li>For size 160, 220: 2x ZBH-9</li> </ul> </li> </ul>	29
4 Switch lug X, Z, O, P, W, R	For sensing the slide position	27
5 Sensor bracket O, P, W, R	Adapter for mounting the inductive proximity sensors (round design) on the axis	27
6 Proximity sensor, M8 O, P, W, R	<ul style="list-style-type: none"> <li>Inductive proximity sensor, round design</li> <li>The order code O, P, W, R includes 1 switch lug and max. 2 sensor brackets</li> </ul>	30
7 Axial kit EAMM-A	For axial motor mounting (consisting of: coupling, coupling housing and motor flange)	24
8 Motor EMME, EMMS	Motors specially matched to the axis, with gear unit, with or without brake	24
9 Slot cover B, S	<ul style="list-style-type: none"> <li>For protecting against the ingress of dirt</li> </ul>	29
10 Proximity sensor, T-slot X, Z	<ul style="list-style-type: none"> <li>Inductive proximity sensor, for T-slot</li> <li>The order code X, Z includes 1 switch lug</li> </ul>	30
11 Connecting cable V	For proximity sensor (order code W and R)	30
12 Clip CL	For mounting the proximity sensor cable in the slot	29
13 Slot nut Y	For mounting attachments	29
14 Adapter kit DHAM	For mounting the support profile on the axis	37
15 Auflageprofil HMIA	For mounting and guiding an energy chain	37
16 Profile mounting M	For mounting the axis on the profile	25
17 Adjusting kit EADC-E16	Used to mount the axis on a vertical surface. Following mounting, the axis can be aligned horizontally	26



# Toothed belt axes EGC-HD-TB, with heavy-duty guide

FESTO

Technical data

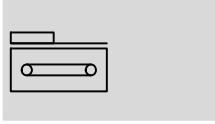
Function



-  Size  
125 ... 220
-  Stroke length  
50 ... 5000 mm
-  [www.festo.com](http://www.festo.com)

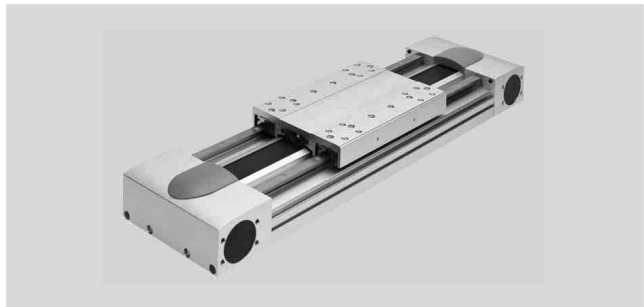

General technical data				
Size		125	160	220
Design		Electromechanical axis with toothed belt		
Guide		Recirculating ball bearing guide		
Mounting position		Any		
Working stroke	[mm]	50 ... 3000	50 ... 5000	50 ... 4750
Max. feed force $F_x$	[N]	450	1000	1800
Max. no-load torque <sup>1)</sup>	[Nm]	1.1	2.1	4.1
Max. no-load resistance to shifting <sup>1)</sup>	[N]	67.75	105.5	123.8
Max. driving torque	[Nm]	7.2	20	59.58
Max. speed				
EGC-...-GK	[m/s]	3	5	
EGC-...-GP	[m/s]	–	3	
Max. acceleration	[m/s <sup>2</sup> ]	40	50	
Repetition accuracy	[mm]	+0.08		+0.1

1) At 0.2 m/s

Operating and environmental conditions		
Ambient temperature	[°C]	–10 ... +60
Protection class		IP40
Duty cycle	[%]	100

Weight [g]				
Size		125	160	220
Basic weight with 0 mm stroke <sup>1)</sup>		4720	9050	25510
Additional weight per 10 mm stroke		73	107	210
Slide				
EGC-...-GK		1218	2571	6317
EGC-...-GP		–	2643	6417
Additional slide				
EGC-...-GK		1026	2022	5498
EGC-...-GP		–	2134	5598

1) Incl. slide

# Toothed belt axes EGC-HD-TB, with heavy-duty guide

Technical data

Toothed belt				
Size		125	160	220
Pitch	[mm]	3	5	8
Width	[mm]	30.3	40.0	50.5
Expansion <sup>1)</sup>	[%]	0.31	0.23	0.29
Effective diameter	[mm]	32.47	39.79	66.21
Feed constant	[mm/rev.]	102	125	208

1) At max. feed force

Mass moment of inertia				
Size		125	160	220
$J_0$	[kg cm <sup>2</sup> ]	4.639	14.49	108.99
$J_S$ per metre stroke	[kg cm <sup>2</sup> /m]	0.38	1.267	6.269
$J_L$ per kg effective load	[kg cm <sup>2</sup> /kg]	2.635	3.96	10.96
$J_W$ Additional slide	[kg cm <sup>2</sup> ]	3.3	11.734	80.66

The mass moment of inertia  $J_A$  of the entire axis is calculated as follows:

$$J_A = J_0 + J_W + J_S \times \text{working stroke [m]} + J_L \times m_{\text{effective load [kg]}}$$

## Materials

Sectional view

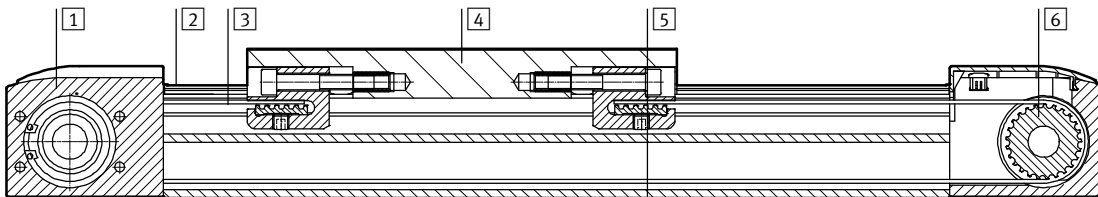

Axis		
1	Drive cover	Anodised wrought aluminium alloy
2	Guide rail	Coated and corrosion-resistant steel
3	Toothed belt	Polychloroprene with glass cord and nylon coating
4	Slide	Anodised wrought aluminium alloy
5	Profile	Anodised wrought aluminium alloy
6	Toothed belt disc	High-alloy stainless steel
Note on materials		Conforms to RoHS
		Contains PWIS (paint-wetting impairment substances)

# Toothed belt axes EGC-HD-TB, with heavy-duty guide

Technical data

## Characteristic load values

The indicated forces and torques refer to the slide surface. The point of application of force is the point where the centre of the guide and the longitudinal centre of the slide intersect.

These values must not be exceeded during dynamic operation. Special attention must be paid to the deceleration phase.

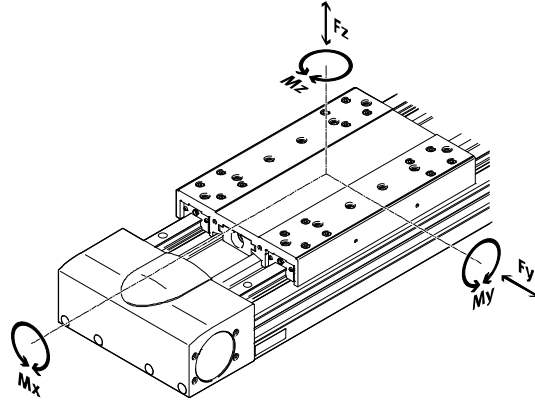

Max. permissible forces and torques for a service life of 5000 km				
Size		125	160	220
F <sub>y,max.</sub>	[N]	3650	5600	13000
F <sub>z,max.</sub>	[N]	3650	5600	13000
M <sub>x,max.</sub>	[Nm]	140	300	900
M <sub>y,max.</sub>	[Nm]	275	500	1450
M <sub>z,max.</sub>	[Nm]	275	500	1450

-  - Note

For a service life of 5000 km for the guide system, the load comparison factor must have a value of  $f_v \leq 1$ , based on the maximum permissible forces and torques for a service life of 5000 km.

If the axis is simultaneously subjected to several of the indicated forces and torques, the following equation must be satisfied in addition to the indicated maximum loads:

Calculating the load comparison factor:

$$f_v = \frac{|F_{y,dyn}|}{F_{y,max}} + \frac{|F_{z,dyn}|}{F_{z,max}} + \frac{|M_{x,dyn}|}{M_{x,max}} + \frac{|M_{y,dyn}|}{M_{y,max}} + \frac{|M_{z,dyn}|}{M_{z,max}} \leq 1$$

# Toothed belt axes EGC-HD-TB, with heavy-duty guide

Technical data

## Calculating service life

The service life of the guide depends on the load. To provide a rough indication of the service life of the guide, the graph below plots the load comparison factor  $f_v$  against the service life.

These values are only theoretical. You must consult your local contact person at Festo for load comparison factors  $f_v$  greater than 1.5.

### Load comparison factor $f_v$ as a function of service life

Example:

A user wants to move an X kg load. Using the formula → page 12 gives a value of 1.5 for the load comparison factor  $f_v$ . According to the graph, the guide would have a service life of approx. 1500 km. Reducing the acceleration reduces the  $M_z$  and  $M_y$  values. A load comparison factor  $f_v$  of 1 now gives a service life of 5000 km.

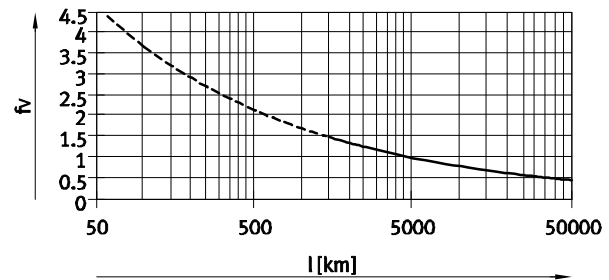

**Note**

PositioningDrives sizing software [www.festo.com](http://www.festo.com)

The guide workload for a service life of 5000 km can be calculated with the help of the sizing software.

$f_v > 1.5$  are only theoretical comparison values for the recirculating ball bearing guide.

## Comparison of the characteristic load values for 5000 km with dynamic forces and torques of recirculating ball bearing guides

The characteristic load values of roller bearing guides are standardised to ISO and JIS using dynamic and static forces and torques. These forces and torques are based on an expected service life for the guide system of 100 km to ISO or 50 km to JIS.

As the characteristic load values are dependent on the service life, the max. permissible forces and torques for a service life of 5000 km cannot be compared with the dynamic forces and torques of roller bearing guides to ISO/JIS.

To make it easier to compare the guide capacity of linear axes EGC with roller bearing guides, the table below lists the theoretically permissible forces and torques for a calculated service life of 100 km. This corresponds to the dynamic forces and torques to ISO.

These 100 km values have been calculated mathematically and are only to be used for comparing with dynamic forces and torques to ISO. The drives must not be loaded with these characteristic values as this could damage them.

Max. permissible forces and torques for a theoretical service life of 100 km (from a guide perspective only)				
Size		125	160	220
$F_{y_{max}}$	[N]	13447	20631	47892
$F_{z_{max}}$	[N]	13447	20631	47892
$M_{x_{max}}$	[Nm]	516	1105	3316
$M_{y_{max}}$	[Nm]	1013	1842	5342
$M_{z_{max}}$	[Nm]	1013	1842	5342

# Toothed belt axes EGC-HD-TB, with heavy-duty guide

Technical data

## Maximum acceleration $a$ as a function of applied load $m$

EGC-HD-125

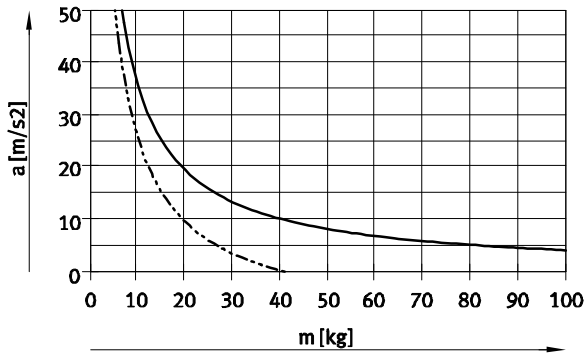

EGC-HD-160

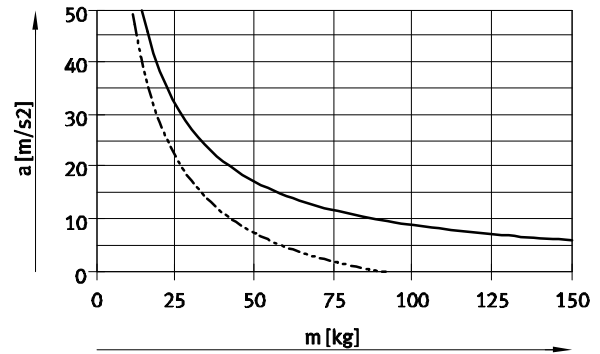

EGC-HD-220

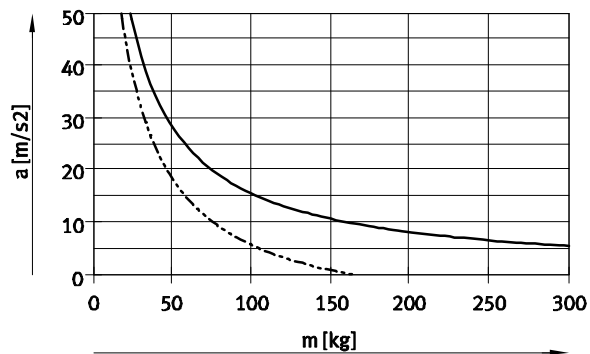

— Horizontal mounting position  
 - - - Vertical mounting position

## Speed $v$ as a function of rotational speed $n$

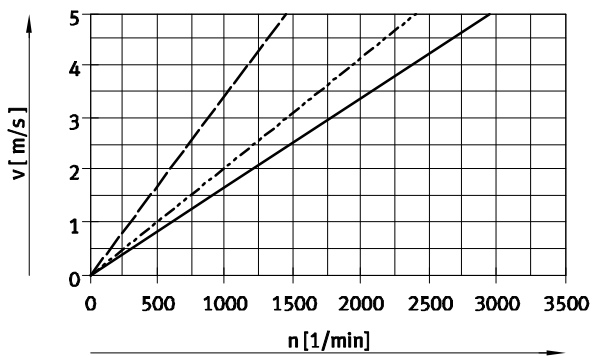

— EGC-HD-125  
 - - - EGC-HD-160  
 - · - EGC-HD-220

# Toothed belt axes EGC-HD-TB, with heavy-duty guide

Technical data

## Theoretical feed force F as a function of input torque M

EGC-HD-125

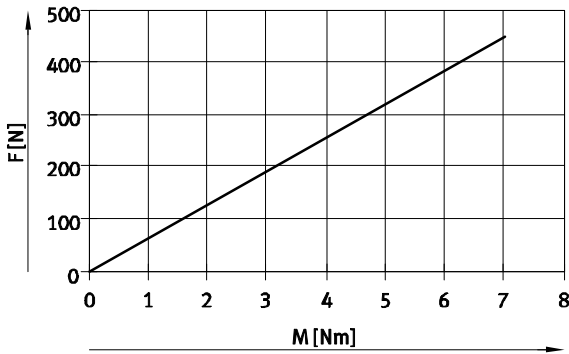

EGC-HD-160

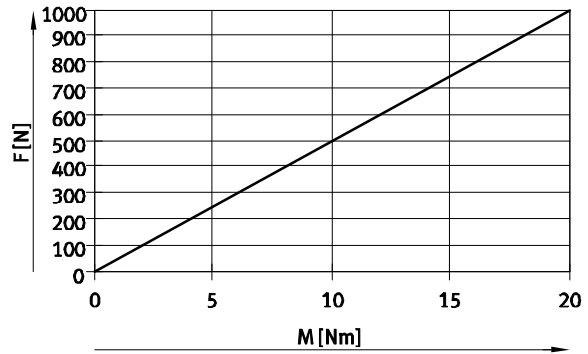

EGC-HD-220

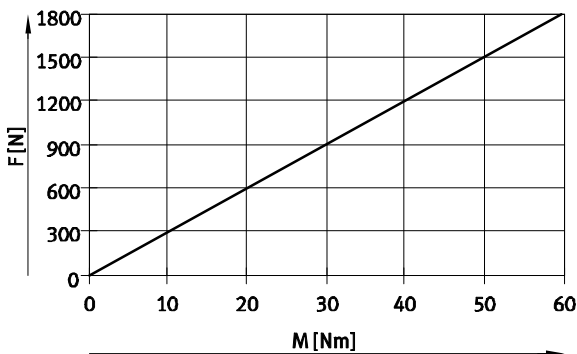

## Stroke reserve

### Stroke length

The selected stroke corresponds in principle to the required working stroke. The variants GK do not have a long-term lubrication unit on the guide. These variants therefore additionally have a safety distance between the drive cap and slide that is not designated as part of the working stroke.

### Stroke reserve

A safety distance (similar to GK) between the drive cap and slide can be defined for the variants GP using the modular product system via the stroke reserve feature. With the variants GK, the stroke reserve and safety distance are added for each end position.

- The stroke reserve length can be freely selected
- The sum of the stroke length and 2x stroke reserve must not exceed the maximum working stroke

### Example:

Type:  
EGC-HD-125-500-TB-20H-...  
Working stroke = 500 mm  
2x stroke reserve = 40 mm  
  
Total stroke = 540 mm  
(540 mm = 500 mm + 2x 20 mm)

Size	125	160	220
L9 = safety distance with GK [mm] (per end position)	12.5	15.5	20

# Toothed belt axes EGC-HD-TB, with heavy-duty guide

Technical data

## Working stroke reduction

With standard slide GK/GP with additional slide KL/KR

- With a toothed belt axis with additional slide, the working stroke is reduced by the length of the additional slide L17 and the distance between both slides L18
- If the variant GP is ordered, the additional slide is also protected

L16 = Length of slide  
 L17 = Length of additional slide  
 L18 = Distance between both slides

### Example:

Type: EGC-HD-220-1000-TB-...-GP-KR

L18 = 100 mm

Working stroke = 1000 mm – 328 mm – 100 mm = 572 mm

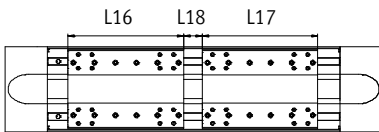

## Dimensions – Additional slide

Size	125	160	220
Variant	GK	GK	GP
Length L17 [mm]	202	220	250

## Working stroke reduction per side

With integrated emergency buffer NPE/shock absorber YSRW with shock absorber retainer EAYH-L2

- With a toothed belt axis, the working stroke is reduced by the total dimension of the emergency buffer/shock absorber and shock absorber retainer.

Size	125	160	220
With emergency buffer [mm]	65	93	98
With shock absorber [mm]	66	94	99

## Second moment of area

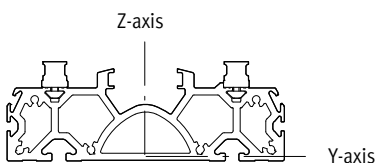

Size	125	160	220
ly [mm <sup>4</sup> ]	6.89x10 <sup>5</sup>	12.9x10 <sup>5</sup>	55.8x10 <sup>5</sup>
lz [mm <sup>4</sup> ]	40.9x10 <sup>5</sup>	98.9x10 <sup>5</sup>	351x10 <sup>5</sup>

# Toothed belt axes EGC-HD-TB, with heavy-duty guide

Technical data

## Maximum permissible support spacing L (without profile mounting) as a function of force F

In order to limit deflection in the case of large strokes, the axis may need to be supported.

The following graphs help to determine the maximum permissible support spacing L as a function of force F acting on the axis. The deflection is  $f = 0.5$  mm.

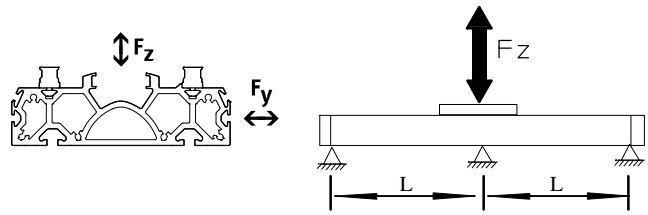

Force Fy

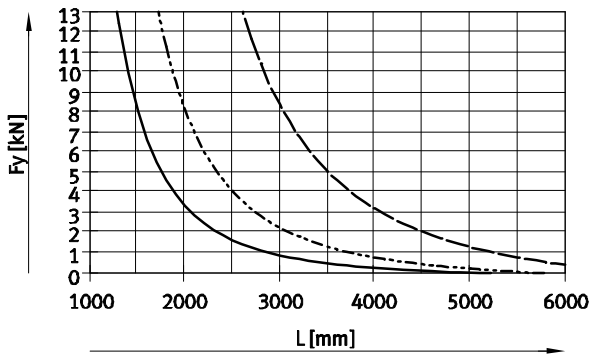

Force Fz

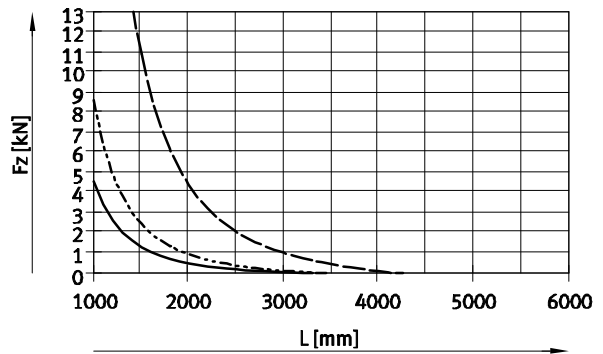

- EGC-HD-125-TB
- - - EGC-HD-160-TB
- · - EGC-HD-220-TB

## Recommended deflection limits

Adherence to the following deflection limits is recommended so as not to impair the functional performance of the axes. Greater deformation can result in increased friction, greater wear and reduced service life.

Size	Dyn. deflection (moving load)	Stat. deflection (stationary load)
125 ... 220	0.05% of the axis length, max. 0.5 mm	0.1% of the axis length

# Toothed belt axes EGC-HD-TB, with heavy-duty guide

Technical data

Dimensions Download CAD data → [www.festo.com](http://www.festo.com)

+ = plus stroke length + 2x stroke reserve  
 L9 With GP: dimension for long-term lubrication unit → page 15

Size	B1	B2	B3	B8	D1 ∅ H7	D2 ∅ H7	D3 ∅	D4 ∅	D7
125	124	120	21	80	43	16	42	25	M6
160	162	150.7	27.5	105	48	16	47	25	M6
220	224	204.2	40	140	80	23	75	45	M8

Size	H1	H2	H3	H4	H7	H8	L1	L2 min.	L3
125	64	26.1	55.8	50.8	24	12	346	173	57.5
160	76.5	28.7	67.5	61.5	26	13	417	208.5	80.5
220	111.5	45.2	98	91.1	59	27	576	288	115

Size	L4	L5	L6	L8	L9	T1	T2	T4	T8
125	46	27.5	1.8	2	–	2.1	27	23.65	13
160	51	32.5	2	0.55	14.9	3.1	27	31.1	14
220	76	50	2	2	18	3.1	29.5	47.5	16

# Toothed belt axes EGC-HD-TB, with heavy-duty guide

Technical data

Dimensions Download CAD data → [www.festo.com](http://www.festo.com)

Profile



- 1 Sensor slot for proximity sensor
- 2 Mounting slot for slot nut

Size	B10	B11	H10
125	122	80	20
160	160	100	20
220	220	140	20

GK – Standard slide

Size 125

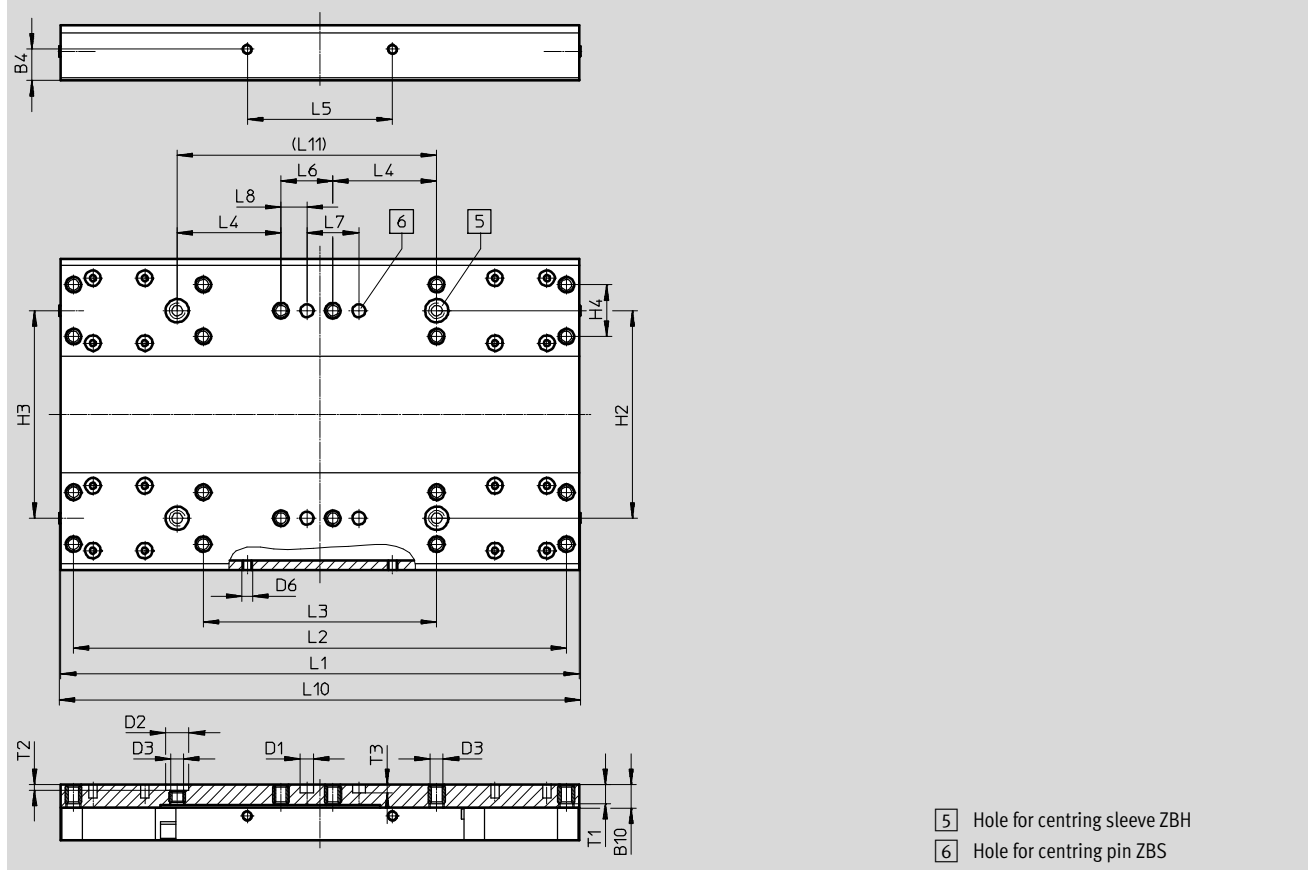

- 5 Hole for centring sleeve ZBH
- 6 Hole for centring pin ZBS

Size	B4	B10	D1	D2	D3	D6	H2	H3	H4	L1	L2	L3
	±0.1		∅ H7	∅ H7			±0.03	±0.05	±0.1	±0.1	±0.2	±0.1
125	12	9	5	9	M5	M4	80	80	20	200	190	90

Size	L4	L5	L6	L7	L8	L10	L11	T1	T2	T3
	±0.1	±0.2	±0.1	±0.03	±0.1		±0.03		+0.1	+0.1
125	40	56	20	20	10	202	100	7.8	2.1	3.1

# Toothed belt axes EGC-HD-TB, with heavy-duty guide

Technical data

Dimensions Download CAD data → [www.festo.com](http://www.festo.com)  
 GK – Standard slide/GP – Standard slide, protected

**Size 160**

5 Hole for centring sleeve ZBH

Size	B4	B10 <sup>*)</sup>	D2 Ø H7	D3	D6	H2	H3
160	±0.1 16.5	10.5	9	M6	M4	±0.03 100	±0.05 105

Size	H10 <sup>*)</sup>	L1	L4	L5	L10 <sup>*)</sup>	T1	T2
160	31	±0.1 220	±0.03 40	±0.1 76	250	9	+0.1 2.1

<sup>\*)</sup> Protected version

# Toothed belt axes EGC-HD-TB, with heavy-duty guide

Technical data

**Dimensions**

Download CAD data → [www.festo.com](http://www.festo.com)

GK – Standard slide/GP – Standard slide, protected

Size 220

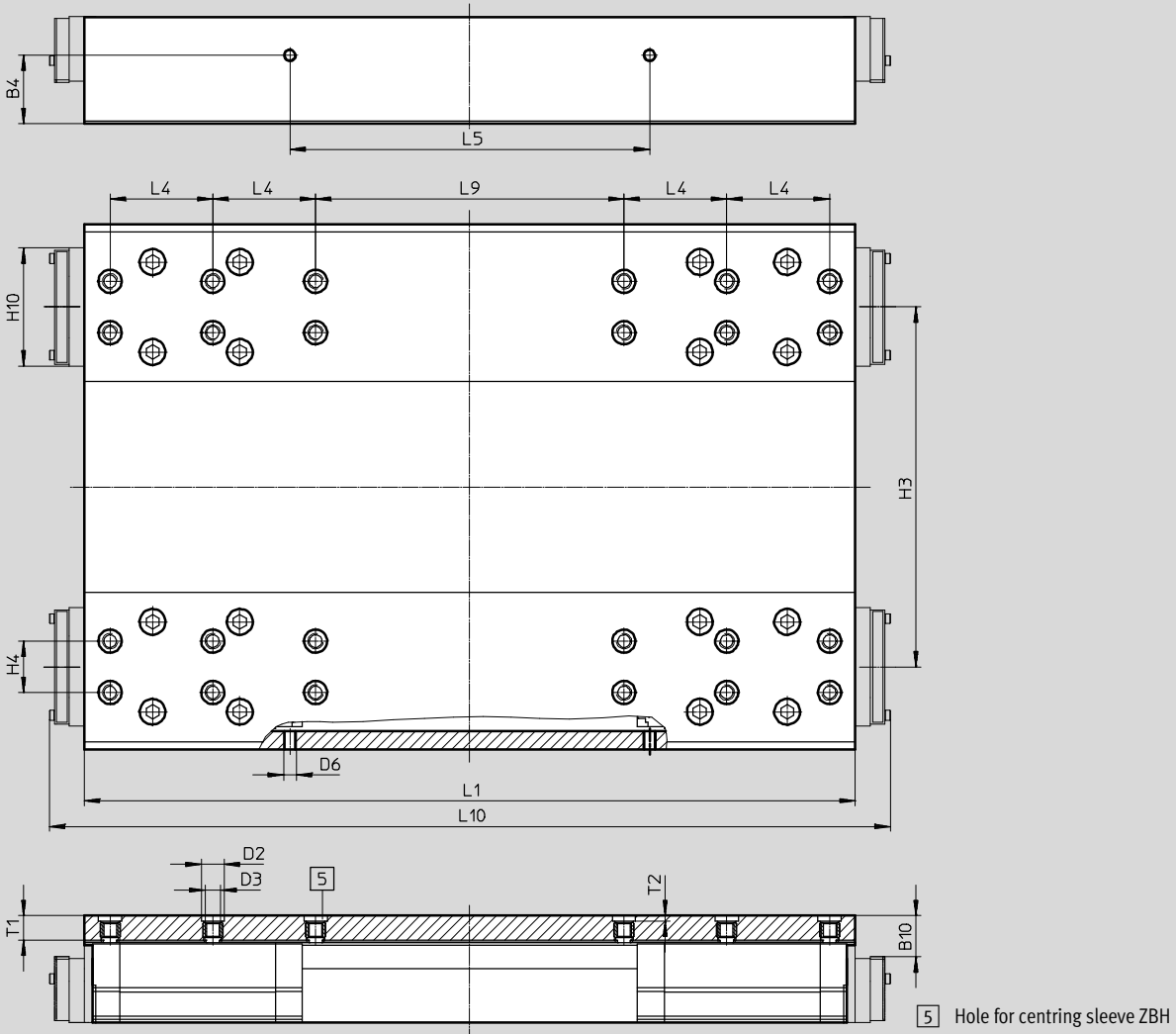

Size	B4	B10 <sup>*)</sup>	D2 ∅ H7	D3	D6	H3	H4	H10 <sup>*)</sup>
220	±0.1 26.6	16	9	M6	M5	±0.05 140	±0.03 20	45.95

Size	L1	L4	L5	L9	L10 <sup>*)</sup>	T1	T2
220	±0.1 302	±0.03 40	±0.1 140	±0.03 120	328	9.5	+0.1 2.1

<sup>\*)</sup> Protected version

# Toothed belt axes EGC-HD-TB, with heavy-duty guide

Ordering data – Modular products

## Order code

Mandatory data

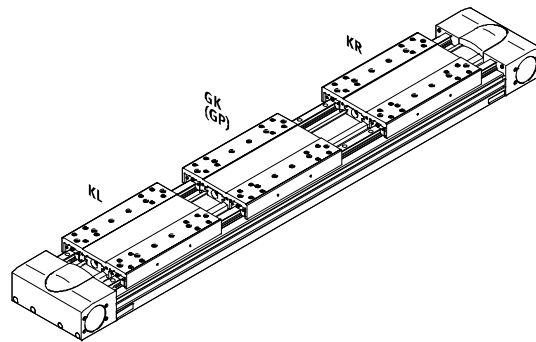
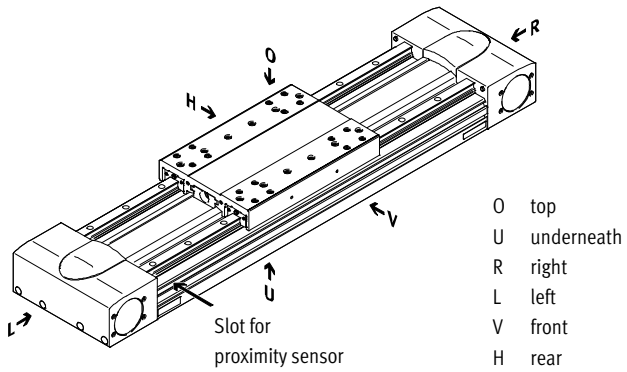

## Accessories

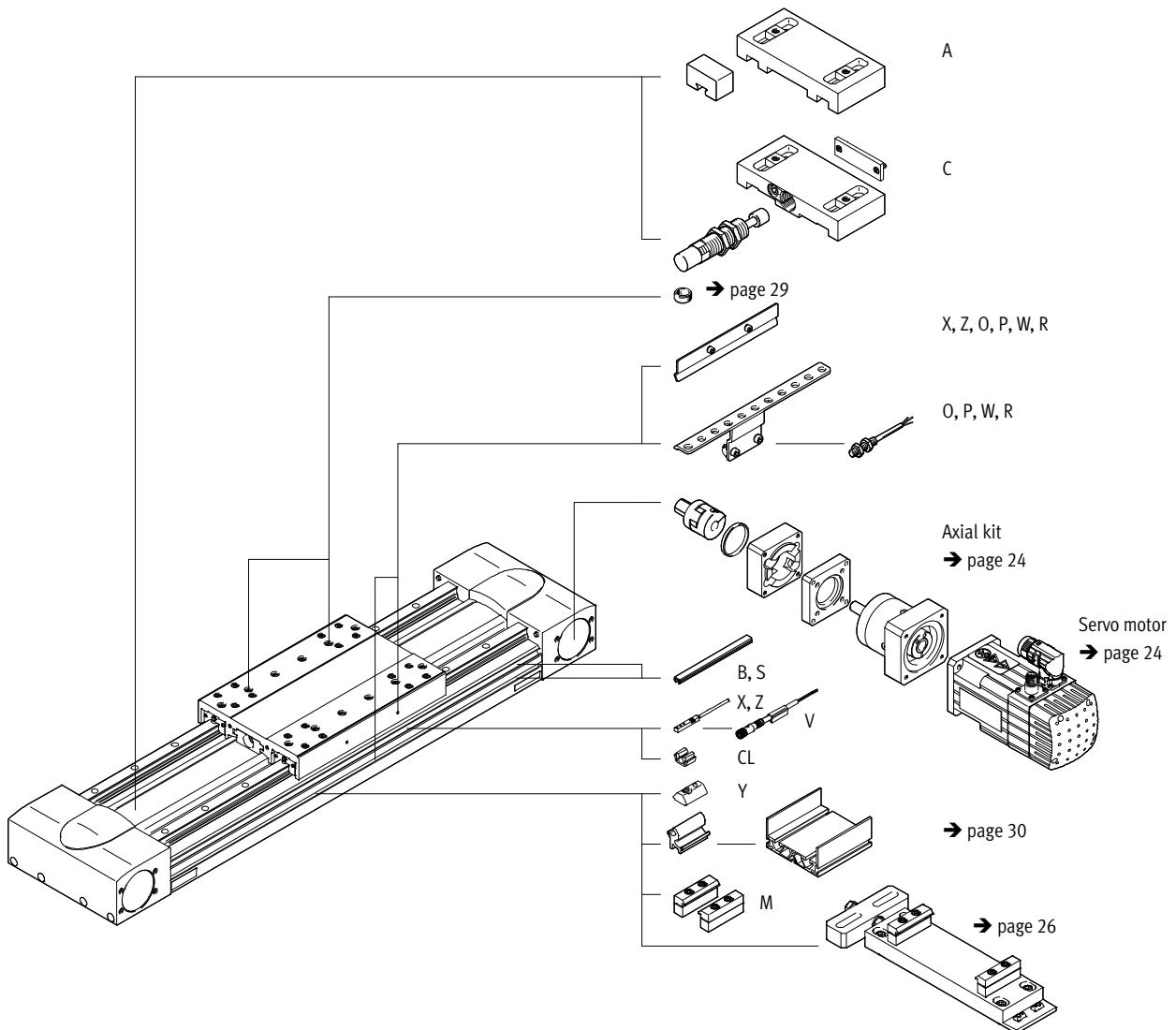

# Toothed belt axes EGC-HD-TB, with heavy-duty guide

Ordering data – Modular products

Ordering table							
Size	125	160	220	Condi- tions	Code		Enter code
<b>M</b> Module No.	<b>556823</b>	<b>556824</b>	<b>556825</b>				
Design	Linear axis				<b>EGC</b>		EGC
Guide	Heavy-duty guide				<b>-HD</b>		-HD
Size	125	160	220		-...		-...
Stroke [mm]	50 ... 3000	50 ... 5000	50 ... 4750	<b>1</b>	-...		-...
Function	Toothed belt				<b>-TB</b>		-TB
Stroke reserve [mm]	0 ... 999 (0 = no stroke reserve)			<b>1</b>	<b>-...H</b>		
Slide	Standard slide				<b>-GK</b>		
	-	Standard slide, protected			<b>-GP</b>		
<b>O</b> Additional slide	Left	Additional slide, standard, on left		<b>2</b>	<b>-KL</b>		
	Right	Additional slide, standard, on right		<b>2</b>	<b>-KR</b>		
Accessories	Accessories enclosed separately				<b>ZUB-</b>		ZUB-
Profile mounting	1 ... 50				<b>...M</b>		
Cover	Mounting slot	1 ... 50 (1 = 2x 500 mm pieces)		<b>4</b>	<b>...B</b>		
	Sensor slot	1 ... 50			<b>...S</b>		
Slot nut for mounting slot	1 ... 99			<b>4</b>	<b>...Y</b>		
Proximity sensor (SIES), inductive, slot type 8, PNP, incl. switch lug	N/O contact, 7.5 m cable	1 ... 6			<b>...X</b>		
	N/C contact, 7.5 m cable	1 ... 6			<b>...Z</b>		
Emergency buffer with retainer	1 ... 2			<b>3</b>	<b>...A</b>		
Shock absorber with retainer	1 ... 2			<b>3</b>	<b>...C</b>		
Proximity sensor (SIEN), inductive, M8, PNP, incl. switch lug with sensor bracket	N/O contact, 2.5 m cable	1 ... 99			<b>...O</b>		
	N/C contact, 2.5 m cable	1 ... 99			<b>...P</b>		
Connecting cable, M8, 3-wire, 2.5 m	N/O contact, plug M8	1 ... 99			<b>...W</b>		
	N/C contact, plug M8	1 ... 99			<b>...R</b>		
Cable clip	10, 20, 30, 40, 50, 60, 70, 80, 90				<b>...CL</b>		
Operating instructions	Express waiver - no user documentation to be included (already available) (operating instructions in PDF format are available free of charge on the Internet at <a href="http://www.festo.com">http://www.festo.com</a> )				<b>-DN</b>		

- 1** -... The sum of the stroke length in mm and 2x the stroke reserve in mm must not exceed the maximum stroke length in mm.
- 2** **KL, KR** If the protected slide variant (GP) is selected, then the additional slide (KL, KR) is also protected.
- 3** ... **A, ... C** Cannot be combined with slide GP.
- 4** **B, Y** Scope of delivery with size 160 for both slot sizes (→ page 36).

- M** Mandatory data
- O** Options

**Order code**

# Toothed belt axes EGC-HD-TB, with heavy-duty guide

Accessories

 Note  
Depending on the combination of motor and drive, it may not be possible to reach the maximum feed force of the drive.

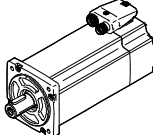
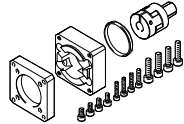
Permissible axis/motor combinations with axial kit		Technical data → Internet: eamm-a	
Motor/gear unit <sup>1)</sup>	Axial kit		
			
Type	Part No.	Type	
<b>EGC-HD-125</b>			
With servo motor and gear unit			
EMMS-AS-55-...	1190076	EAMM-A-M43-60G	
EMGA-60-P-G...-SAS-55			
EMMT-AS-60-...	1456612	EAMM-A-M43-60H	
EMGA-60-P-G...-EAS-60			
EMME-AS-60-...	1456612	EAMM-A-M43-60H	
EMGA-60-P-G...-EAS-60			
EMMS-AS-70-...	1190076	EAMM-A-M43-60G	
EMGA-60-P-G...-SAS-70			
With servo motor and angled gear unit			
EMMT-AS-60-...	1456612	EAMM-A-M43-60H	
EMGA-60-A-G...-60P			
EMME-AS-60-...	1456612	EAMM-A-M43-60H	
EMGA-60-A-G...-60P			
With stepper motor and gear unit			
EMMS-ST-57-...	1190076	EAMM-A-M43-60G	
EMGA-60-P-G...-SST-57			
With integrated drive and gear unit			
EMCA-EC-67-...	1456612	EAMM-A-M43-60H	
EMGC-60-...			

1) The input torque must not exceed the maximum permissible transferable torque of the axial kit.

# Toothed belt axes EGC-HD-TB, with heavy-duty guide

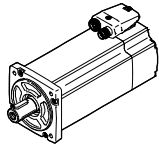
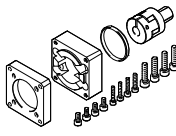

Accessories

Permissible axis/motor combinations with axial kit		Technical data → Internet: eamm-a
Motor/gear unit <sup>1)</sup>	Axial kit	
		
Type	Part No.	Type
<b>EGC-HD-160</b>		
With servo motor and gear unit		
EMMT-AS-60-... EMGA-60-P-G...-EAS-60	1456614	EAMM-A-M48-60H
EMME-AS-60-... EMGA-60-P-G...-EAS-60	1456614	EAMM-A-M48-60H
EMMS-AS-70-... EMGA-80-P-G...-SAS-70	1190421	EAMM-A-M48-80G
EMME-AS-80-... EMGA-80-P-G...-EAS-80	1190421	EAMM-A-M48-80G
EMME-AS-100-... EMGA-80-P-G...-SAS-100	1190421	EAMM-A-M48-80G
EMMS-AS-100-... EMGA-80-P-G...-SAS-100	1190421	EAMM-A-M48-80G
With servo motor and angled gear unit		
EMMT-AS-60-... EMGA-60-A-G...-60P	1456614	EAMM-A-M48-60H
EMME-AS-60-... EMGA-60-A-G...-60P	1456614	EAMM-A-M48-60H
EMME-AS-80-... EMGA-80-A-G...-80P	1190421	EAMM-A-M48-80G
EMME-AS-100-... EMGA-80-A-G...-100A	1190421	EAMM-A-M48-80G
With stepper motor and gear unit		
EMMS-ST-87-... EMGA-80-P-G...-SST-87	1190421	EAMM-A-M48-80G
With integrated drive and gear unit		
EMCA-EC-67-... EMGC-60-...	1456614	EAMM-A-M48-60H
<b>EGC-HD-220</b>		
With servo motor and gear unit		
EMME-AS-100-... EMGA-120-P-G...-SAS-100	1190774	EAMM-A-M80-120G
EMMS-AS-100-... EMGA-120-P-G...-SAS-100	1190774	EAMM-A-M80-120G
EMMS-AS-140-... EMGA-120-P-G...-SAS-140	1190774	EAMM-A-M80-120G

1) The input torque must not exceed the maximum permissible transferable torque of the axial kit.

# Toothed belt axes EGC-HD-TB, with heavy-duty guide

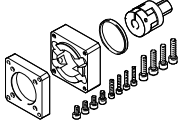
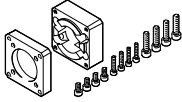
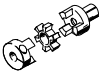
Accessories

Permissible axis/motor combinations with axial kit			Technical data → Internet: eamm-a
Axial kit	Axial kit comprises:		
	Motor flange	Coupling	Centring ring
			
Part No. Type	Part No. Type	Part No. Type	Part No. Type
<b>EGC-HD-125</b>			
1190076 EAMM-A-M43-60G	1597579 EAMF-A-43D-60G/H	558001 EAMD-32-32-11-16X20	575962 EAML-43-4-43
1456612 EAMM-A-M43-60H	1597579 EAMF-A-43D-60G/H	1377840 EAMD-32-32-14-16X20	575962 EAML-43-4-43
<b>EGC-HD-160</b>			
1456614 EAMM-A-M48-60H	1460111 EAMF-A-48C-60G/H	3420022 EAMD-42-40-14-16X25-U	558031 EAML-48-4-48
1190421 EAMM-A-M48-80G	1190375 EAMF-A-48C-80G	1781043 EAMD-42-40-20-16X25-U	558031 EAML-48-4-48
<b>EGC-HD-220</b>			
1190774 EAMM-A-M80-120G	1190702 EAMF-A-80A-120G	1781045 EAMD-56-46-25-23X27-U	1209006 EAML-80-6-80

# Toothed belt axes EGC-HD-TB, with heavy-duty guide

Accessories

**Profile mounting MUE**  
(order code M)

Materials:  
Anodised aluminium  
RoHS-compliant

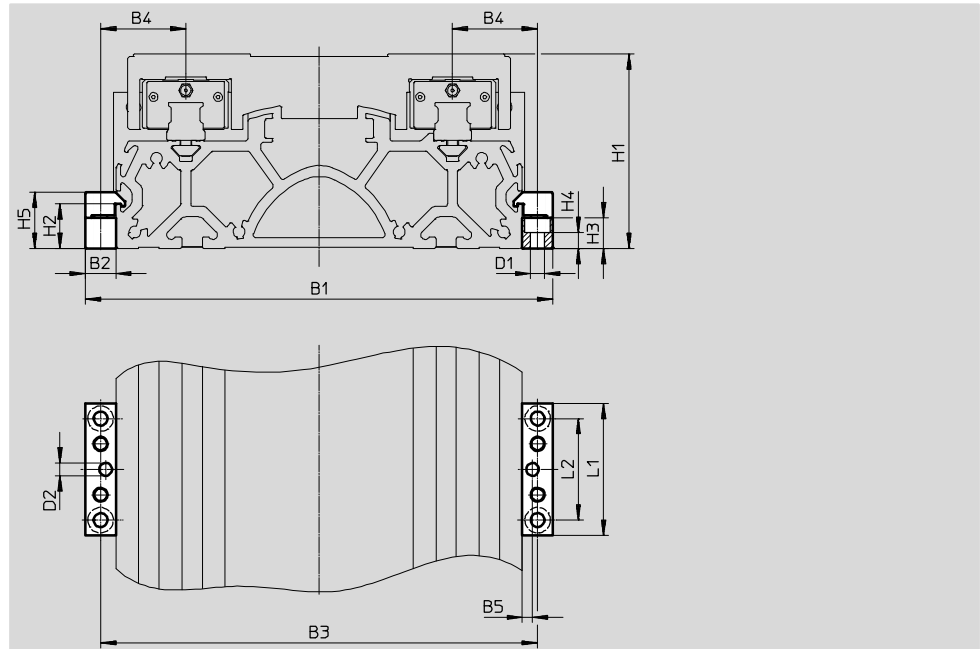
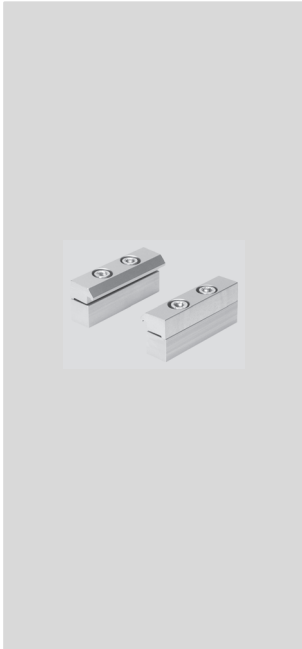

Dimensions and ordering data									
For size	B1	B2	B3	B4	B5	D1 ∅	D2 ∅ H7	H1	H2
125	146	12	134	27	4	5.5	5	64	17.5
160	184	12	172	33.5	4	5.5	5	76.5	17.5
220	258	19	239	49.5	4	9	5	111.5	16

For size	H3	H4	H5	L1	L2	Weight [g]	Part No.	Type
125	12	6.2	22	52	40	80	558043	MUE-70/80
160	12	6.2	22	52	40	80	558043	MUE-70/80
220	14	5.5	29.5	90	40	290	558044	MUE-120/185

# Toothed belt axes EGC-HD-TB, with heavy-duty guide

Accessories

## Adjusting kit EADC-E16

Materials:  
Wrought aluminium alloy  
RoHS-compliant

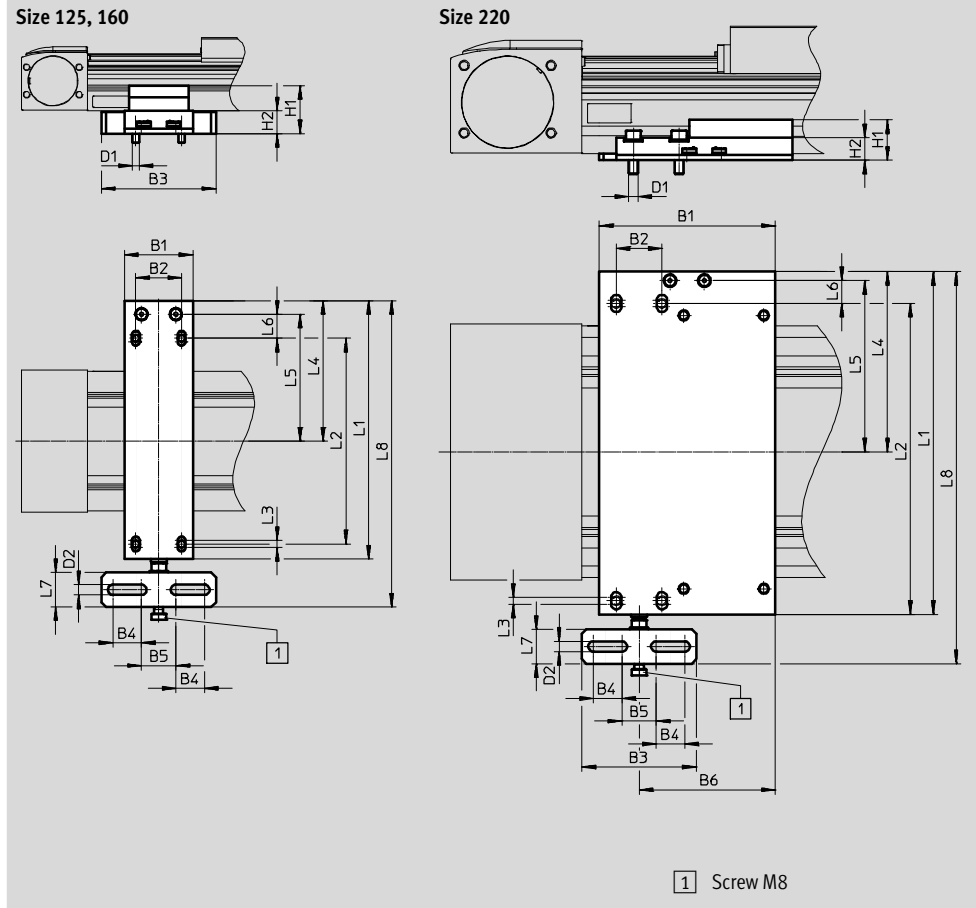
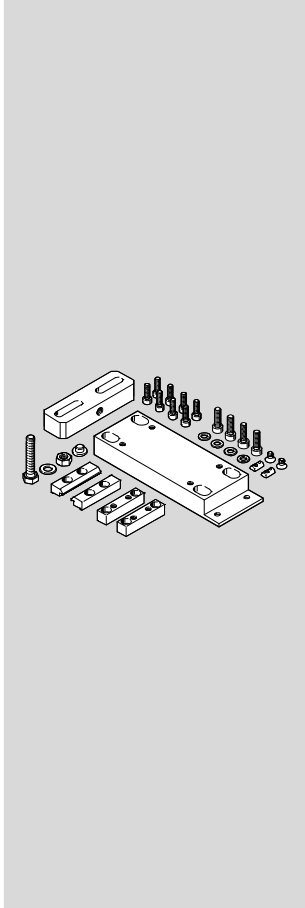

Dimensions and ordering data												
For size	B1	B2	B3	B4	B5	B6	D1	D2	H1	H2	L1	L2
125	60	40	100	25	30	-	M6	9	42	20	226	180
160	60	40	100	25	30	-	M6	9	44	22	266	220
220	154	40	100	25	30	119	M8	9	35.1	19.6	300	260

For size	L3	L4	L5	L6	L7	L8	Weight [g]	Part-No.	Type
125	6	123	111	21	30	308	974	8047580	EADC-E16-125-E14
160	6	143	131	21	30	343	1189	8047581	EADC-E16-160-E14
220	6	157.7	149.7	20	30	343	1500	8047582	EADC-E16-220-E14

# Toothed belt axes EGC-HD-TB, with heavy-duty guide

Accessories

## Shock absorber retainer, retainer EAYH

Emergency buffer NPE → page 31  
Shock absorber YSRW → page 31  
(order code A or C)

Materials:  
Anodised aluminium  
RoHS-compliant

Cannot be used in combination with the variants GP.

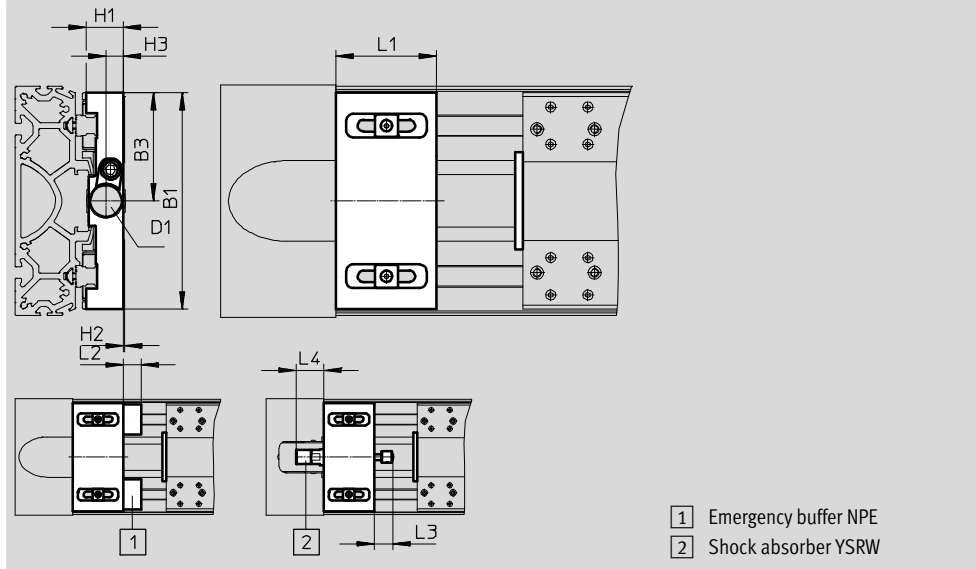
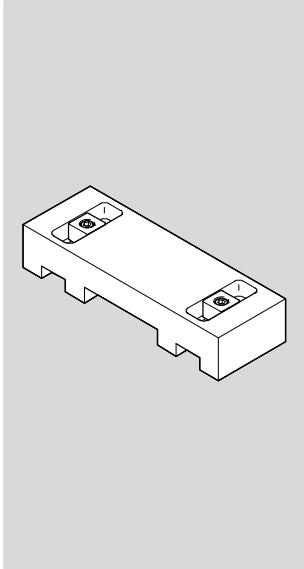

Dimensions and ordering data													
For size	B1	B3	D1	H1	H2	H3	L1	L2	L3	L4 Min.	Weight [g]	Part No.	Type
<b>Shock absorber retainer</b>													
125	120	60	M16x1	19.8	0.4	9.7	50	-	20	36	286	1653251	EAYH-L2-125
160	150.7	75.3	M22x1.5	26.2	0.8	12.3	70	-	26	38.5	622	1653250	EAYH-L2-160
220	204	102	M26x1.5	38.7	0.1	15	70	-	34	63.5	1218	1653253	EAYH-L2-220
<b>Retainer for emergency buffer</b>													
125	120	-	-	19.8	0.4	-	50	17	-	-	260	1662803	EAYH-L2-125-N
160	150.7	-	-	26.2	0.8	-	70	25	-	-	617	1669259	EAYH-L2-160-N
220	204	-	-	38.7	0.1	-	70	30	-	-	1195	1669260	EAYH-L2-220-N

## Switch lug SF-EGC-HD-1

For sensing via proximity sensor  
SIES-8M  
(order code X or Z)

Materials:  
Galvanised steel  
RoHS-compliant

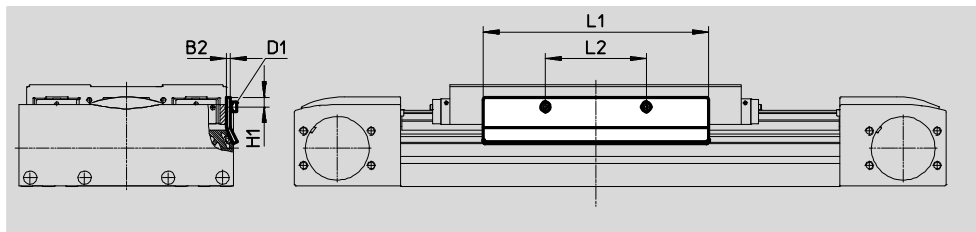

Dimensions and ordering data								
For size	B2	D1	H1	L1	L2	Weight [g]	Part No.	Type
125	2	M4x8	7.8	150	56	70	570027	SF-EGC-HD-1-125
160	3	M4x8	7.3	170	76	160	1645872	SF-EGC-HD-1-160
220	3	M5x10	11.5	250	140	310	1645866	SF-EGC-HD-1-220

# Toothed belt axes EGC-HD-TB, with heavy-duty guide



Accessories

## Switch lug SF-EGC-HD-2

For sensing via proximity sensor  
SIEN-M8B (order code O, P, W or R) or  
SIES-8M (order code X or Z)

Materials:  
Galvanised steel  
RoHS-compliant

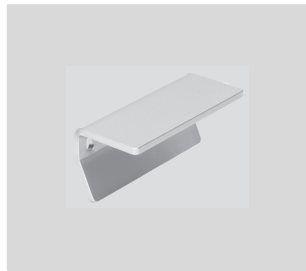

## Sensor bracket HWS-EGC

For proximity sensor SIEN-M8B  
(order code O, P, W or R)

Materials:  
Galvanised steel  
RoHS-compliant

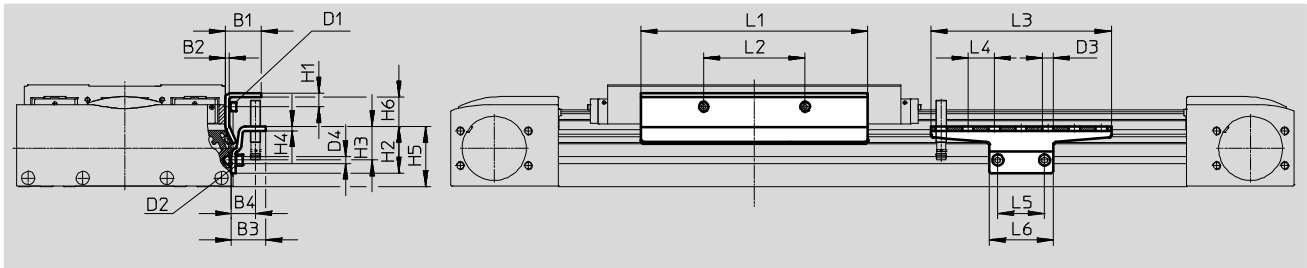

### Dimensions and ordering data

For size	B1	B2	B3	B4	D1	D2	D3	D4	H1	H2
125	24	2	25.5	18	M4x8	M5x8	8.4	5.2	9	35
160	27	3	25.5	18	M4x8	M5x8	8.4	5.2	10.3	35
220	31	3	25.5	18	M5x10	M5x14	8.4	5.2	11.5	65





For size	H3	H4	H5	H6	L1	L2	L3	L4	L5	L6
125	25	3	45	14	150	56	135	20	35	48
160	25	3	45	22.2	170	76	135	20	35	48
220	55	3	75	18.4	250	140	215	20	35	48

For size	Weight [g]	Part No.	Type
Switch lug			
125	122	570030	SF-EGC-HD-2-125
160	261	1645865	SF-EGC-HD-2-160
220	430	1645868	SF-EGC-HD-2-220

For size	Weight [g]	Part No.	Type
Sensor bracket			
125	110	558057	HWS-EGC-M5
160	110	558057	HWS-EGC-M5
220	217	570365	HWS-EGC-M8-B

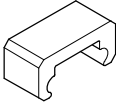
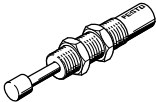
# Toothed belt axes EGC-HD-TB, with heavy-duty guide

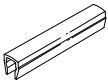
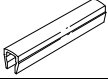
Accessories

Ordering data						
	For size	Comment	Order code	Part No.	Type	PU <sup>1)</sup>
<b>Emergency buffer NPE</b>						
	125	Use in combination with retainer EAYH	A	<b>1662475</b>	<b>NPE-125</b>	1
	160			<b>1672593</b>	<b>NPE-160</b>	
	220			<b>1672598</b>	<b>NPE-220</b>	
<b>Shock absorber YSRW</b> <span style="float: right;">Technical data → Internet: ysrw</span>						
	125	Use in combination with shock absorber retainer EAYH	C	<b>191196</b>	<b>YSRW-12-20</b>	1
	160			<b>191197</b>	<b>YSRW-16-26</b>	
	220			<b>191198</b>	<b>YSRW-20-34</b>	
<b>Slot nut NST</b>						
	125, 160 <sup>2)</sup>	For mounting slot	Y	<b>150914</b>	<b>NST-5-M5</b>	1
				<b>8047843</b>	<b>NST-5-M5-10</b>	10
				<b>8047878</b>	<b>NST-5-M5-50</b>	50
	160 <sup>3)</sup> , 220	For mounting slot	Y	<b>150915</b>	<b>NST-8-M6</b>	1
				<b>8047868</b>	<b>NST-8-M6-10</b>	10
				<b>8047869</b>	<b>NST-8-M6-50</b>	50
<b>Centring pin/sleeve ZBS/ZBH</b>						
	125	For slide	-	<b>150928</b>	<b>ZBS-5</b>	10
	125, 160, 220			<b>150927</b>	<b>ZBH-9</b>	
<b>Slot cover ABP</b>						
	125, 160 <sup>2)</sup>	For mounting slot Every 0.5 m	B	<b>151681</b>	<b>ABP-5</b>	2
	160 <sup>3)</sup> , 220			<b>151682</b>	<b>ABP-8</b>	
<b>Slot cover ABP-S</b>						
	125, 160, 220	For sensor slot Every 0.5 m	S	<b>563360</b>	<b>ABP-5-S1</b>	2
<b>Clip SMBK</b>						
	125, 160, 220	For sensor slot, for attaching the proximity sensor cables	CL	<b>534254</b>	<b>SMBK-8</b>	10

- 1) Packaging unit quantity
- 2) For mounting slot at side
- 3) For mounting slot underneath

# Toothed belt axes EGC-HD-TB, with heavy-duty guide

Accessories

## Mounting options between axis and support profile

Depending on the adapter kit, the spacing between the axis and the support profile is:  
x = 20 mm or 50 mm

The support profile must be mounted using at least 2 adapter kits. For longer strokes, an adapter kit must be used every 500 mm.

Example:

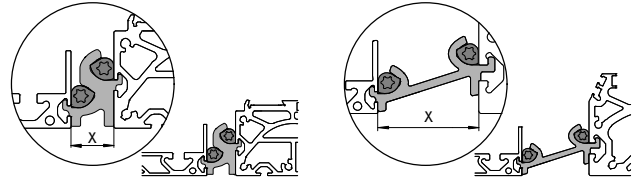

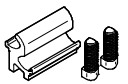
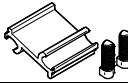
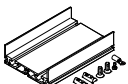

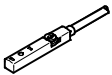
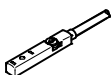

Ordering data					
	For size	Comment	Part No.	Type	PU <sup>1)</sup>
<b>Adapter kit DHAM</b>					
	160	<ul style="list-style-type: none"> <li>For mounting the support profile on the axis</li> <li>Spacing between axis and profile is 20 mm</li> </ul>	562241	DHAM-ME-N1-CL	1
	220		562242	DHAM-ME-N2-CL	
	125, 160	<ul style="list-style-type: none"> <li>For mounting the support profile on the axis</li> <li>Spacing between axis and profile is 50 mm</li> </ul>	574560	DHAM-ME-N1-50-CL	
	220		574561	DHAM-ME-N2-50-CL	
<b>Support profile HMIA</b>					
	70 ... 120	<ul style="list-style-type: none"> <li>For guiding an energy chain</li> </ul>	539379	HMIA-E07-	1



1) Packaging unit quantity

Ordering data – Proximity sensor for T-slot, inductive							Technical data → Internet: sies	
	Type of mounting	Electrical connection	Switching output	Cable length [m]	Order code	Part No.	Type	
<b>N/O contact</b>								
	Insertable in the slot from above, flush with the cylinder profile	Cable, 3-wire	PNP	7.5	X	551386	SIES-8M-PS-24V-K-7,5-OE	
		Plug connector M8x1, 3-pin		0.3	–	551387	SIES-8M-PS-24V-K-0,3-M8D	
		Cable, 3-wire	NPN	7.5	–	551396	SIES-8M-NS-24V-K-7,5-OE	
		Plug connector M8x1, 3-pin		0.3	–	551397	SIES-8M-NS-24V-K-0,3-M8D	
<b>N/C contact</b>								
	Insertable in the slot from above, flush with the cylinder profile	Cable, 3-wire	PNP	7.5	Z	551391	SIES-8M-PO-24V-K-7,5-OE	
		Plug connector M8x1, 3-pin		0.3	–	551392	SIES-8M-PO-24V-K-0,3-M8D	
		Cable, 3-wire	NPN	7.5	–	551401	SIES-8M-NO-24V-K-7,5-OE	
		Plug connector M8x1, 3-pin		0.3	–	551402	SIES-8M-NO-24V-K-0,3-M8D	

# Toothed belt axes EGC-HD-TB, with heavy-duty guide

Accessories

Ordering data – Proximity sensors M8 (round design), inductive							Technical data → Internet: sien	
	Electrical connection	LED	Switching output	Cable length [m]	Order code	Part No.	Type	
<b>N/O contact</b>								
	Cable, 3-wire	■	PNP	2.5	O	150386	SIEN-M8B-PS-K-L	
			NPN	2.5	–	150384	SIEN-M8B-NS-K-L	
	Plug connector M8x1, 3-pin	■	PNP	–	W	150387	SIEN-M8B-PS-S-L	
			NPN	–	–	150385	SIEN-M8B-NS-S-L	
<b>N/C contact</b>								
	Cable, 3-wire	■	PNP	2.5	P	150390	SIEN-M8B-PO-K-L	
			NPN	2.5	–	150388	SIEN-M8B-NO-K-L	
	Plug connector M8x1, 3-pin	■	PNP	–	R	150391	SIEN-M8B-PO-S-L	
			NPN	–	–	150389	SIEN-M8B-NO-S-L	

Ordering data – Connecting cables					Technical data → Internet: nebu	
	Electrical connection, left	Electrical connection, right	Cable length [m]	Part No.	Type	
	Straight socket, M8x1, 3-pin	Cable, open end, 3-wire	2.5	159420	SIM-M8-3GD-2,5-PU	
			2.5	541333	NEBU-M8G3-K-2.5-LE3	
			5	541334	NEBU-M8G3-K-5-LE3	
	Angled socket, M8x1, 3-pin	Cable, open end, 3-wire	2.5	541338	NEBU-M8W3-K-2.5-LE3	
			5	541341	NEBU-M8W3-K-5-LE3	

# Festo - Your Partner in Automation



**1 Festo Inc.**  
5300 Explorer Drive  
Mississauga, ON L4W 5G4  
Canada

**Festo Customer Interaction Center**  
Tel: 1 877 463 3786  
Fax: 1 877 393 3786  
Email: [customer.service.ca@festo.com](mailto:customer.service.ca@festo.com)



**2 Festo Pneumatic**  
Av. Ceylán 3,  
Col. Tequesquináhuac  
54020 Tlalneantla,  
Estado de México

**Multinational Contact Center**  
01 800 337 8669  
[ventas.mexico@festo.com](mailto:ventas.mexico@festo.com)



**3 Festo Corporation**  
1377 Motor Parkway  
Suite 310  
Islandia, NY 11749

**Festo Customer Interaction Center**  
1 800 993 3786  
1 800 963 3786  
[customer.service.us@festo.com](mailto:customer.service.us@festo.com)



**4 Regional Service Center**  
7777 Columbia Road  
Mason, OH 45040

Connect with us



[www.festo.com/socialmedia](http://www.festo.com/socialmedia)



[www.festo.com](http://www.festo.com)

Subject to change