

Rotary indexing tables DHTG



Rotary indexing tables DHTG

Key features

At a glance

- Sturdy mechanical system
- Easy planning and commissioning
- Indexing: 2, 3, 4, 6, 8, 12, 24
- Integrated functions:
 - Overload protection
 - Sensor function
 - Cushioning adjustment
- Speed setting
- Changing the direction of rotation

The technology in detail

- 1 Through-hole for energy throughfeed
- 2 Thread for position sensing
- 3 One-way flow control valve for regulating speed
- 4 Supply port for reciprocating motion
- 5 Supply port for clockwise or anticlockwise rotation
- 6 Adjusting screw for cushioning adjustment

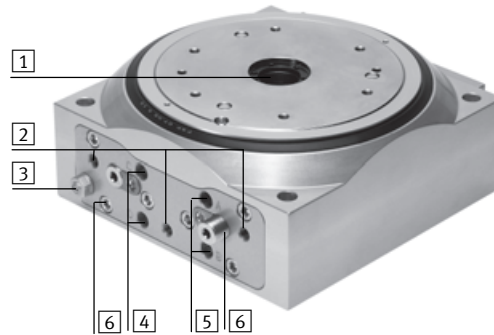

Control options

Clockwise

- Just one valve required

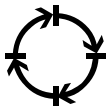

Anticlockwise

- Just one valve required

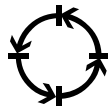

Reciprocating motion

- After conversion with a reciprocating motion kit
- Two valves required



Flexible control: Clockwise, anticlockwise, reciprocating motion

- After conversion with a reciprocating motion kit
- Two valves required

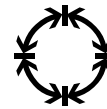

Examples for simple interfaces

Clockwise/anticlockwise

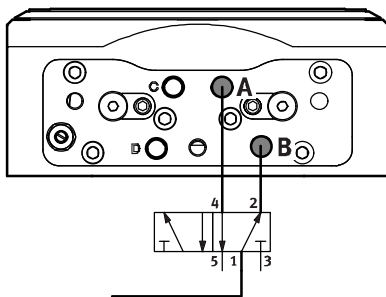

Reciprocating motion/flexible control

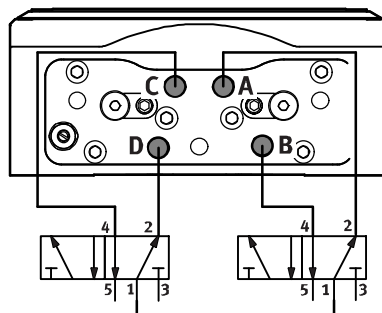

Rotary indexing tables DHTG

Key features

The technology in detail

Overload protection

To prevent the rotary indexing table from being damaged by an excessive mass moment of inertia, e.g. during setting operation or in the event of shock absorber failure, sizes 140 and 220 feature overload protection. If the mass moment of inertia is too large, the securing pin is pressed against the spring force by the result-

ing radial force. It then slides forward on the toothed segment. This shift in position between the index plate and toothed segment means that the securing pin can no longer engage and the rotary indexing table does not move. The table can be made ready for use again by turning it back.

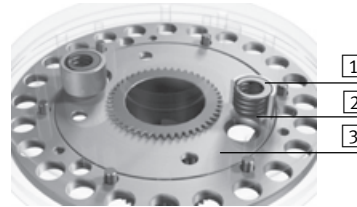

- 1 Securing pin
- 2 Spring
- 3 Toothed segment

Energy throughfeed

Electrical signals or compressed air can be transferred through the hollow shaft using the energy throughfeed. This enables fast and easy supply of the parts connected to the rotary table.

Also suitable for IO-Link signal data transfer.

- 1 Electrical connection (output)
- 2 Housing, energy throughfeed
- 3 Supply port (output)
- 4 Rotary indexing table
- 5 Supply port (input)
- 6 Electrical connection (input)



Mounting options

Direct mounting from above

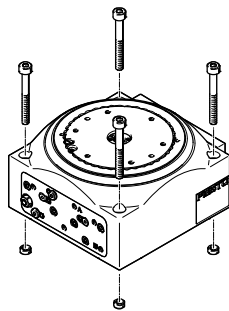

Direct mounting from below

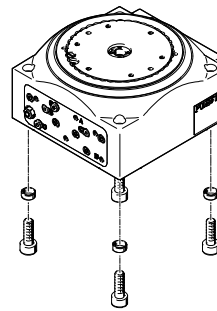

Rotary indexing tables DHTG

Key features

Application examples

Basic rotary table

- Handling with minimum space requirement

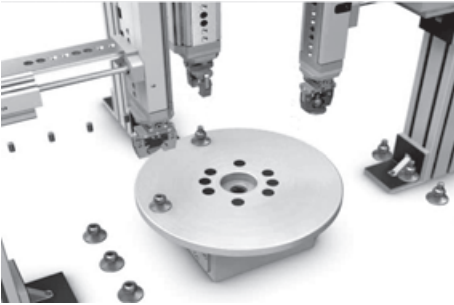

Rotary table with rotary distributor

- For the transfer of compressed air and vacuum to the rotary table
- With 1 or 2 separate ducts



Rotary table with stationary centre section

- For the mounting of handling units or other devices in the centre of the rotary indexing table



 Note
The rotary indexing tables are not designed for the following or similar sample applications:

- Machining
- Aggressive media

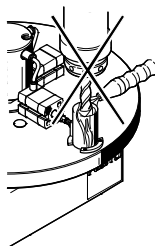

- Grinding dust

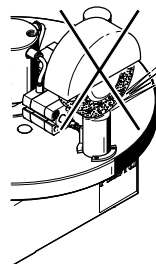

- Welding spatter

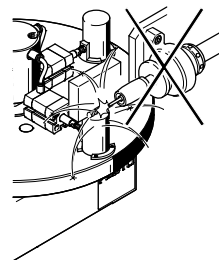

Rotary indexing tables DHTG

Type codes

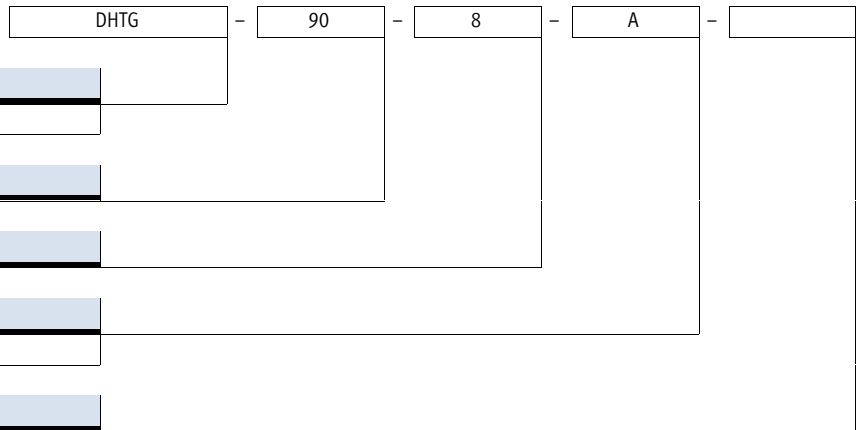

Series	
DHTG	Rotary indexing table
Size	
Indexing	
Position sensing	
A	Via proximity sensor
Energy throughfeed	
-	None
P4	Pneumatic, 4 ducts
P4E4	Pneumatic, 4 ducts electric, 4 signals
P4L12	Pneumatic, 4 ducts electric, 12 cables

Rotary indexing tables DHTG

Peripherals overview

FESTO

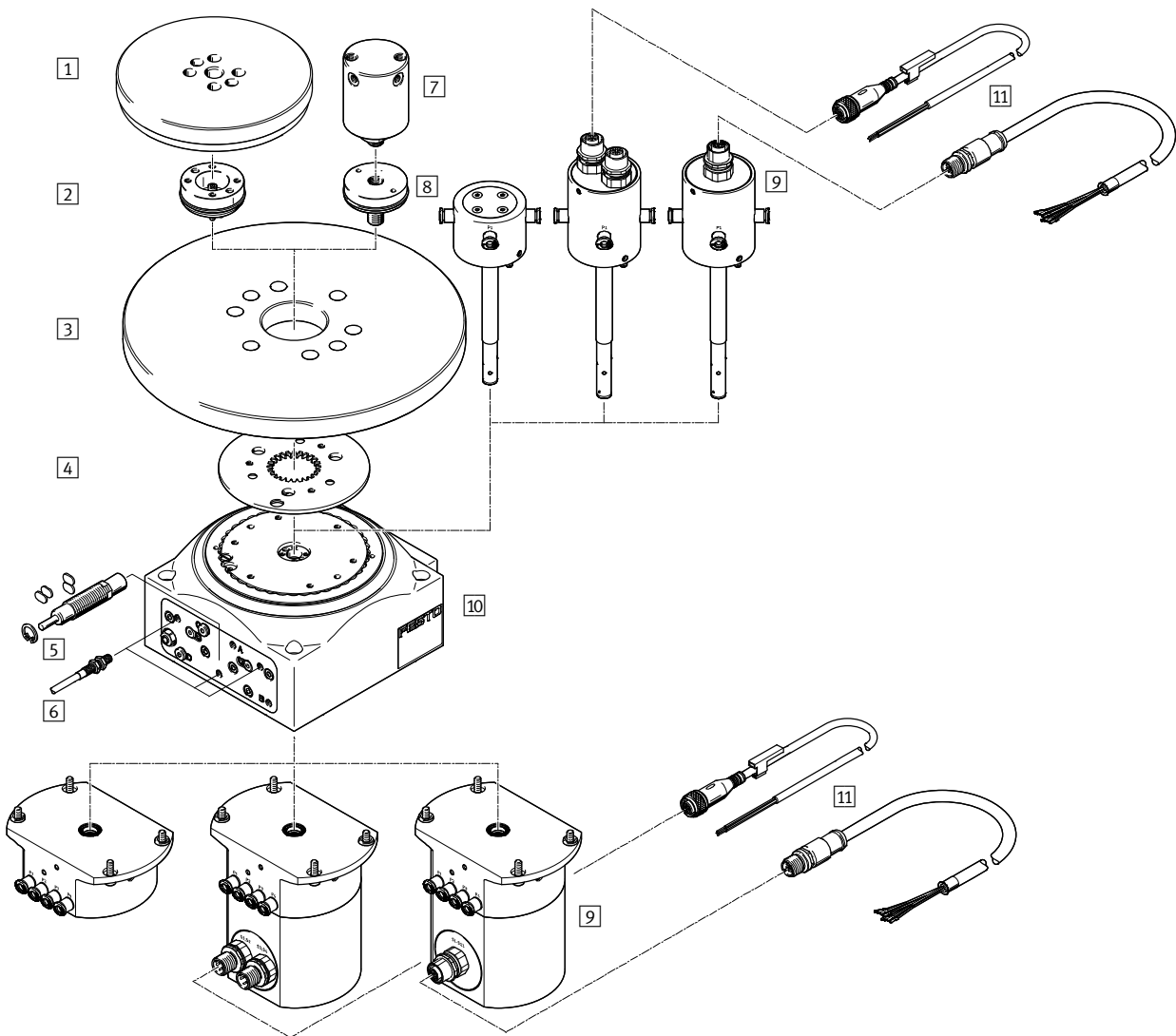

Rotary indexing tables DHTG

Peripherals overview

Variants and accessories		
Type	Description	→ Page/Internet
1 Plate, fixed	For illustration purposes only, not included in the scope of delivery	28
2 Adapter kit DADG-AK	For mounting a blank plate on the rotary indexing table	28
3 Plate, rotary	For illustration purposes only, not included in the scope of delivery	28
4 Indexing conversion kit DADM-CK	The step angles can be adjusted at any time using the kit	30
5 Reciprocating motion kit DADM-TK	Allows conversion from movement in one direction to reciprocating motion	30
6 Proximity sensor SIEN	For sensing the switching position of the rotary indexing table	30
7 Rotary distributor GF	Distributes the compressed air fed through the centre of the rotary indexing table to the actuators on the rotating blank plate. Cannot be used in combination with a fixed blank plate	29
8 Adapter kit DADG-AK-...-...G...	For mounting the rotary distributor on the rotary indexing table	29
9 Pneumatic/electric energy throughfeed	For quick and easy pneumatic/electrical supply of parts connected to the rotary plate	12
10 Rotary indexing table DHTG	Flexible application range: anticlockwise rotation, clockwise rotation or reciprocating motion	8
11 Connecting cables NEBU, NEBS	For transmitting the signals	31

Rotary indexing tables DHTG

Technical data

Size
65, 90, 140, 220

Indexing
2, 3, 4, 6, 8, 12, 24

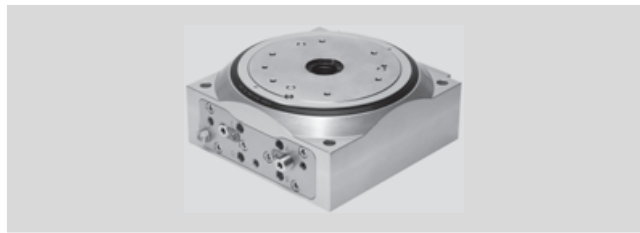

General technical data									
Size	65		90		140		220		
Pneumatic connection	M5			G $\frac{1}{8}$					
Design	Gear coupling								
	Rack and pinion								
	Force pilot operated motion sequence								
Mode of operation	Double-acting								
Type of mounting	Via through-hole and centring sleeve								
Mounting position	Any								
Cushioning	Adjustable shock absorber stroke, hard characteristic curve								
Indexing	2, 3, 4, 6, 8, 12, 24			3, 4, 6, 8, 12, 24					
Torque at 6 bar	[Nm]	2.1	4.4	18.1	58.9				
Parallelism of plate ¹⁾	[mm]	≤ 0.04							
Axial eccentricity of plate ²⁾	[mm]	≤ 0.02							
Concentricity of plate ³⁾	[mm]	≤ 0.02							
Repetition accuracy of swivel angle	[°]	≤ 0.03							
Max. mass moment of inertia without flow control ⁴⁾	[kgm ²]	0.016	0.03	0.3	2.5				
Cycle time without flow control		→ page 10							
Position sensing		Via inductive proximity sensors							
Weight									
DHTG-...	[kg]	2.0	4.5	10	24				
DHTG-...-P4	[kg]	4.39	6.89	12.49	26.64				
DHTG-...-P4E4	[kg]	5.12	7.62	13.22	27.37				
DHTG-...-P4L12	[kg]	5.15	7.65	13.25	27.40				

- 1) Parallelism of plate surface to housing support
- 2) Measured on the surface of the plate at the edge of the plate in relation to the housing support
- 3) Measured on the inner diameter of the plate in relation to the housing
- 4) Operation with flow control can increase the mass moment of inertia by 50%. The service life of the shock absorber is reduced in this case. The mass moment of inertia depends on the number of stations and the switching frequency (→ page 11)

Note

The "clockwise" rotation of the table can be controlled via an internal flow control valve in combination with the reciprocating motion kit. For "anti-clockwise" rotation, external actuation via an additional one-way flow control valve GRLA is needed.

Operating and environmental conditions	
Operating medium	Compressed air in accordance with ISO 8573-1:2010 [7:4:4]
Note on operating/pilot medium	Lubricated operation possible (in which case lubricated operation will always be required)
Operating pressure	[bar] 4 ... 8
Ambient temperature	[°C] 5 ... 60
Storage temperature	[°C] -20 ... +80
Degree of protection	IP54 ²⁾
Corrosion resistance class CRC ¹⁾	2

- 1) Corrosion resistance class CRC 2 to Festo standard FN 940070
Moderate corrosion stress. Indoor applications in which condensation may occur. External visible parts with primarily decorative requirements for the surface and which are in direct contact with the ambient atmosphere typical for industrial applications.
- 2) The specified degree of protection applies to the top side of the rotary indexing table. The underside must be provided with appropriate external protection for the environment.

Rotary indexing tables DHTG

Technical data

Static characteristic load values

The indicated forces and torques refer to the locked table and can also act on the table plate.



Size		65	90	140	220
Forces					
Max. axial force F	[N]	1000	2000	4000	5000
Max. radial force R	[N]	2000	5000	6000	8000
Torque					
Max. tilting torque M	[Nm]	100	150	300	500
Max. tangential torque T	[Nm]	100	150	200	500

Materials

Sectional view

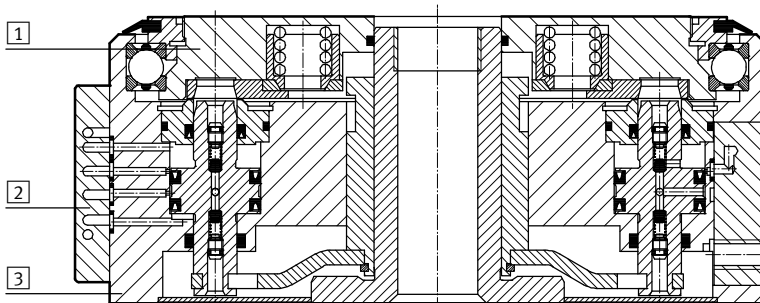

Rotary indexing table	
1	Plate Galvanised steel
2	Cap Wrought aluminium alloy
3	Housing Wrought aluminium alloy
-	Stops Galvanised steel
-	Seals NBR, TPE-U (PU)
Note on materials	
DHTG-...	Free of copper and PTFE
DHTG-...-P4...	Cables with PTFE insulation
	Contains paint-wetting impairment substances

Rotary indexing tables DHTG

Technical data

Calculation of the cycle time

The rotary indexing tables are equipped with a hydraulic shock absorber, which means that the max. frequency of the shock absorber must also be taken into account when calculating the cycle time.

The switching time comprises:
 Switching time = Unlock, rotate, lock and return stroke of working piston.
 The cycle time is calculated as follows:
 Cycle time = Switching time + Processing time + Dwell time.

In the switching frequency graph, the max. achievable switching frequency is read in relation to the mass moment of inertia. The switching time can be calculated from this as follows:
 $T = 60/f$. The processing time is calculated from the time required by

the respective customer application (e.g. time for component removal, press-in time, etc.). A dwell time may be necessary if the cycle time is shorter than the min. possible cycle time.

Calculation example

DHTG-140 with 8 indexing stations and a mass moment of inertia of 0.1 kgm².

The customer application requires 300 ms per step for the insertion and removal of parts.

Switching frequency

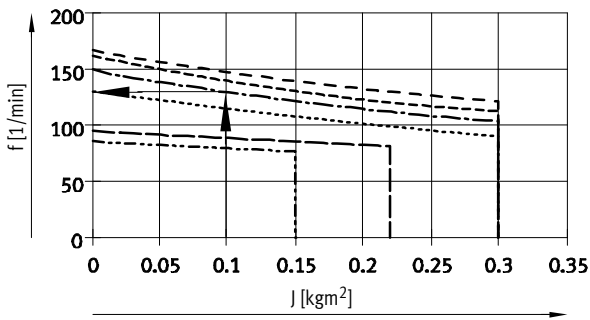

$$T_{\text{Switchingtime}} = \frac{1}{f} = \frac{60s}{130} = 0.461s = 461ms$$

Dwell time = Min. permissible cycle time – Switching time – Processing time
 Dwell time = 1017 ms – 461 ms – 300 ms = 256 ms.

Given the fact that the switching time + processing time is shorter than the min. permissible cycle time, the rotary indexing table must stay in the end position

before the next step is performed. In other words, between the circuits an additional dwell time of 256 ms must be allowed for in the control sequence.

Max. permissible cycle frequency

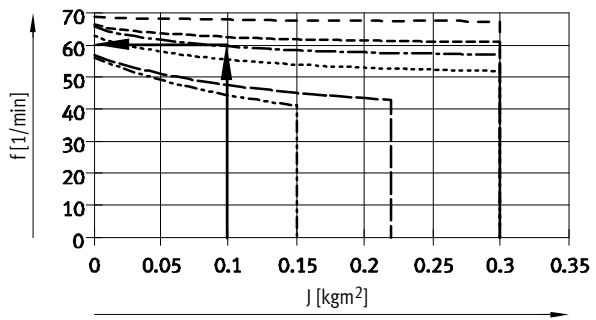

$$T_{\text{Min.permissiblecyclotime}} = \frac{60s}{59} = 1.017s = 1017ms$$

Rotary indexing tables DHTG

Technical data



Mass moment of inertia J as a function of switching frequency f and number of stations

Size 65

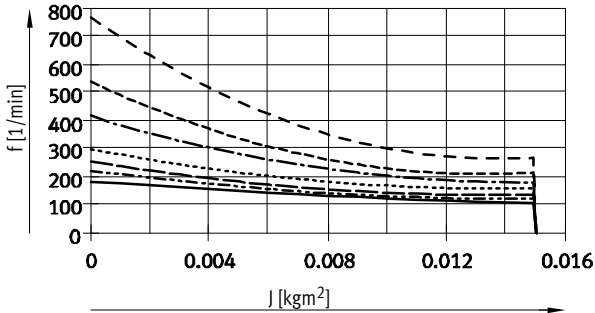

Size 90

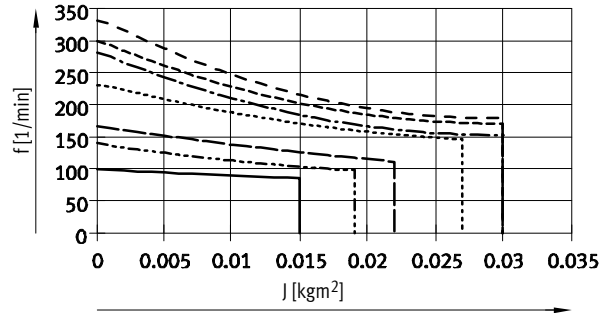

Size 140

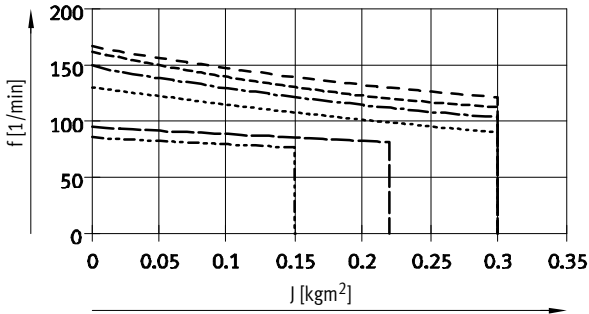

Size 220

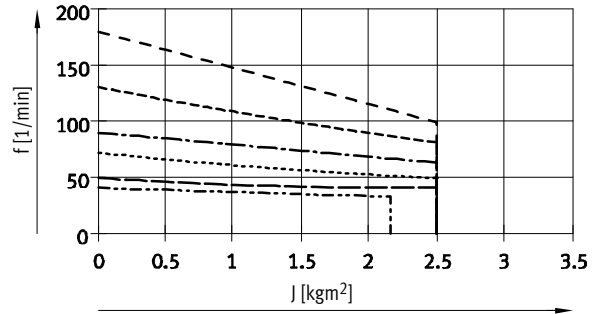

Max. permissible cycle frequency f as a function of mass moment of inertia J

Size 65

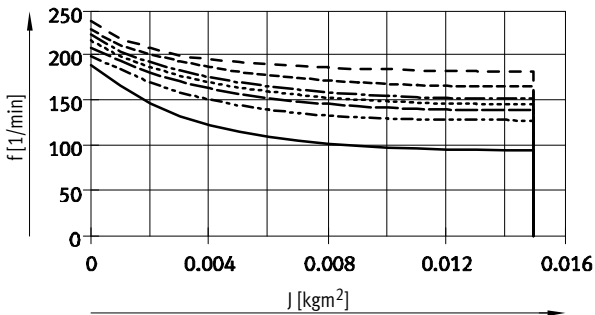

Size 90

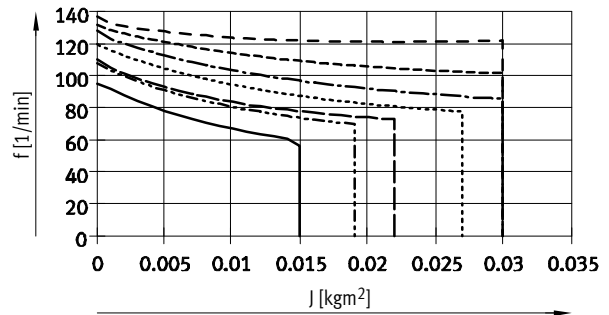

Size 140

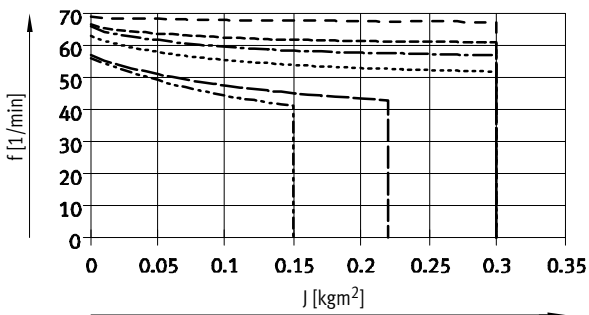

Size 220

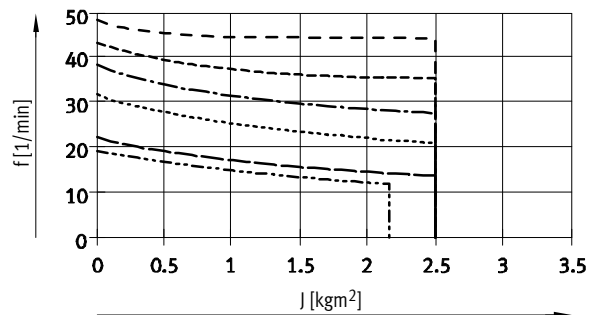

- | | |
|-------------------------------|----------------------------|
| ————— 2 indexing stations | ----- 8 indexing stations |
| - - - - - 3 indexing stations | ----- 12 indexing stations |
| ----- 4 indexing stations | ----- 24 indexing stations |
| 6 indexing stations | |

Rotary indexing tables DHTG

Technical data

Energy throughfeed

DHTG-...-P4

DHTG-...-P4E4

DHTG-...-P4L12



Function	Benefits		
Electrical signals or compressed air can be transferred through the hollow shaft using the energy throughfeed.	<ul style="list-style-type: none"> Fast and easy supply of the parts connected to the rotary table 	<ul style="list-style-type: none"> Tubing and electrical cables are not damaged by the rotation 	<ul style="list-style-type: none"> Two variants available: <ul style="list-style-type: none"> Pneumatic Pneumatic and electrical

Pneumatic DHTG-...-P4

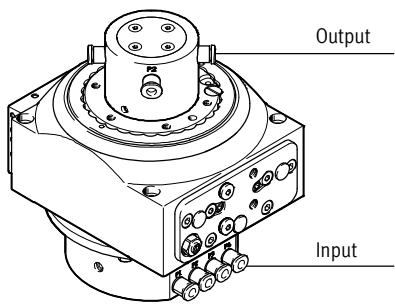

Pneumatic/electrical DHTG-...-P4E4

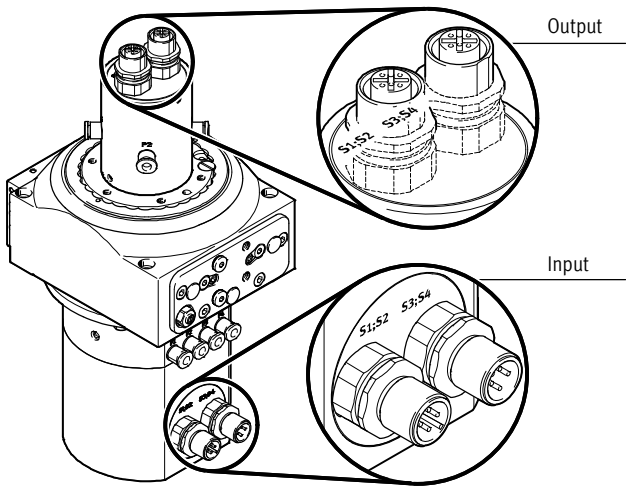

DHTG-...-P4L12

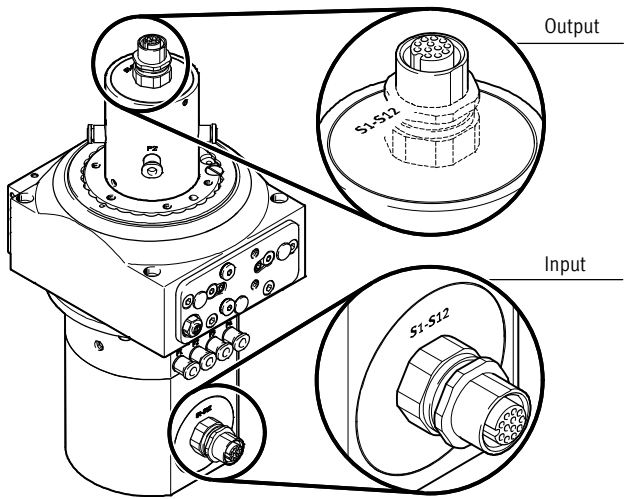

Rotary indexing tables DHTG

Technical data

Technical data			
Variant	Pneumatic	Pneumatic/electrical	Pneumatic/electrical
Order code	P4	P4E4	P4/L12
Pneumatic			
Number of pneumatic ducts	4	4	4
Tubing O.D.	4		
Max. operating pressure [bar]	8		
Connection	M5		
Flow rate per duct [l/min.]	86		
Electrical			
Number of signal lines	–	4	12 ¹⁾
Rated voltage [DC V]	–	30	30
Max. current ¹⁾ [A]	–	1.5	1.5
Cable cross section [mm ²]	–	0.14	0.14
Connection	–	M12	M12

1) Freely configurable

Pin allocation – Energy throughfeed, electrical

DHTG-...-P4E4

Input M12 plug				Output M12 socket			
Designation	Pin allocation	Pin	Circuit diagram	Circuit diagram	Pin	Pin allocation	Designation
S1;S2	+	1			1	+	S1;S2
	Sig 2	2				Sig 2	
	–	3			2	–	
	Sig 1	4				Sig 1	
S3;S4	+	1			3	+	S3;S4
	Sig 4	2				Sig 4	
	–	3			4	–	
	Sig 3	4				Sig 3	

DHTG-...-P4L12

Input M12 socket		Output M12 socket	
Designation	Circuit diagram	Circuit diagram	Designation
Sig 1 ... 12 freely configurable			Sig 1 ... 12 freely configurable

Note
Only connecting cables with straight connectors can be used (➔ 31).

Rotary indexing tables DHTG

Technical data

FESTO

Dimensions

Download CAD data → www.festo.com

Size 65

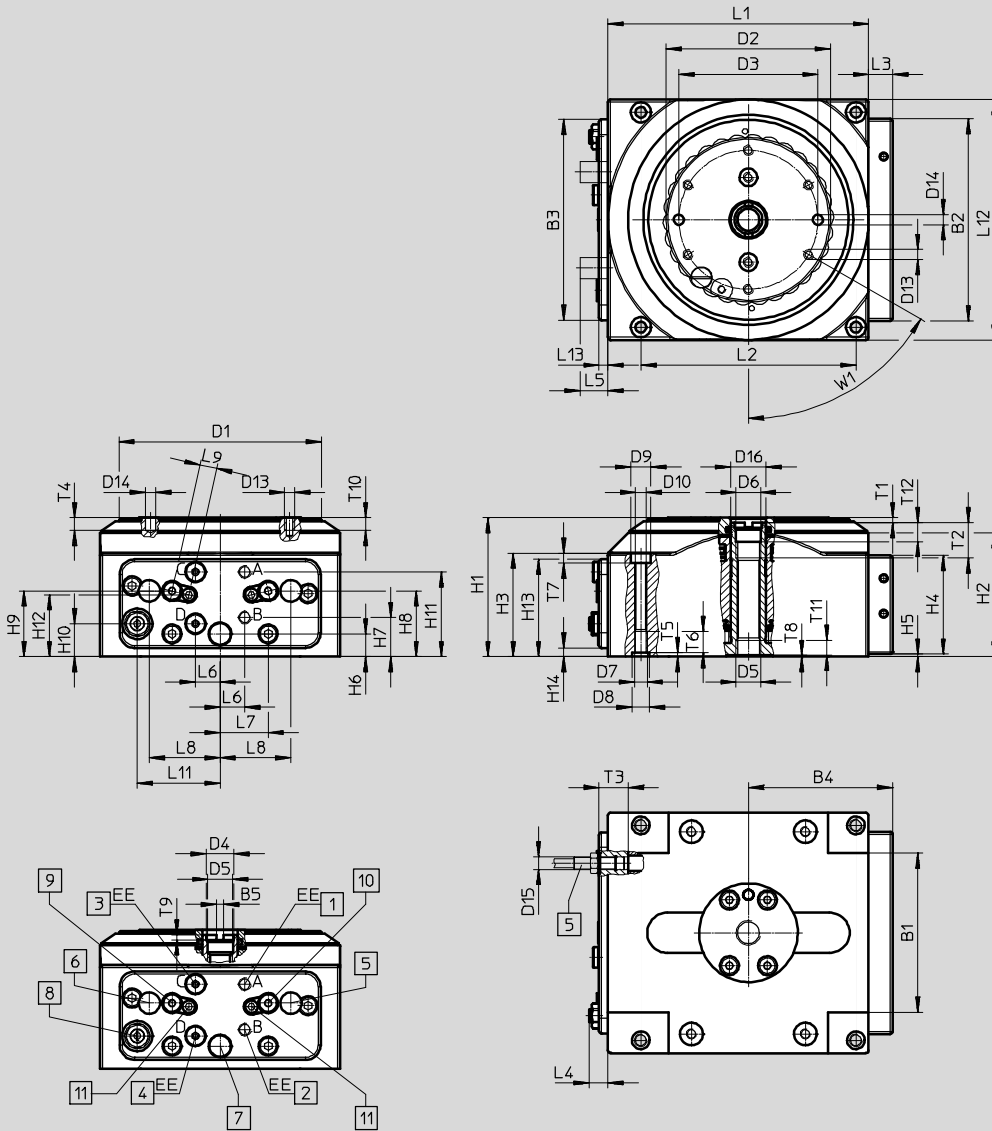

- | | | | |
|--|---|---|---|
| <p>1 Supply port: unlock and rotate (reciprocating motion: unlock)</p> <p>2 Supply port: lock and return stroke (reciprocating motion: lock)</p> <p>3 Blanking plug (for reciprocating motion: rotate supply port clockwise)</p> | <p>4 Blanking plug (for reciprocating motion: rotate supply port anticlockwise)</p> <p>5 Sensor turned for clockwise rotation (sensor initial position for anticlockwise rotation)</p> <p>6 Sensor initial position for clockwise rotation (sensor turned for anticlockwise rotation)</p> | <p>7 Sensor lock</p> <p>8 One-way flow control valve</p> <p>9 Adjustment of end-position cushioning for anticlockwise rotation and reciprocating motion (not applicable for clockwise rotation)</p> | <p>10 Adjustment of end-position cushioning for clockwise rotation and reciprocating motion (not applicable for anticlockwise rotation)</p> <p>11 Counter-torque for end-position cushioning 2.5 Nm</p> |
|--|---|---|---|

Rotary indexing tables DHTG

Technical data

Size	B1 ³⁾ ±2	B2	B3	B4	B5 +0.1	D1 ∅	D2 ∅	D3 ¹⁾ ∅	D4 ∅	D5	D6 ∅ H8	D7
65	63	80	79.5	47.5	3	80	65	55	11	G ¹ / ₈	10	M5

Size	D8 ∅ H8	D9 ∅	D10 ∅	D13	D14 ∅ H8	D15	D16 ∅ H8	EE	H1 ±0.5	H2	H3	H4
65	7	8	4.3	M4	4	M5x0.5	14	M5	55	49	41	39

Size	H5	H6	H7	H8	H9	H10	H11	H12	H13	H14	L1 ±0.1	L2 ¹⁾ □
65	1	9	15.5	26	26	13	33.5	24.5	38.5	3.5	103	85

Size	L3	L4 +1	L5 ²⁾ Max.	L6	L7	L8	L9	L11	L12 ±0.1	L13 +0.1	T1 ±1	T2 Min.
65	9.5	7.5	11	9.75	19	28	6.75	32.75	95	3.5	2	14

Size	T3 Min.	T4 Min.	T5 +0.1	T6 Min.	T7	T8	T9	T10 Min.	T11 Min.	T12	W1
65	12	5	1.6	10	4	0.5	2	6	5	7	60°

- 1) Tolerance between the centring holes: ±0.02
Tolerance between the threaded holes and countersinks: ±0.2
- 2) Max. projection of shock absorber adjustment
- 3) 0.1 +0.05 recessed

Rotary indexing tables DHTG

Technical data

FESTO

Dimensions

Download CAD data → www.festo.com

Size 90

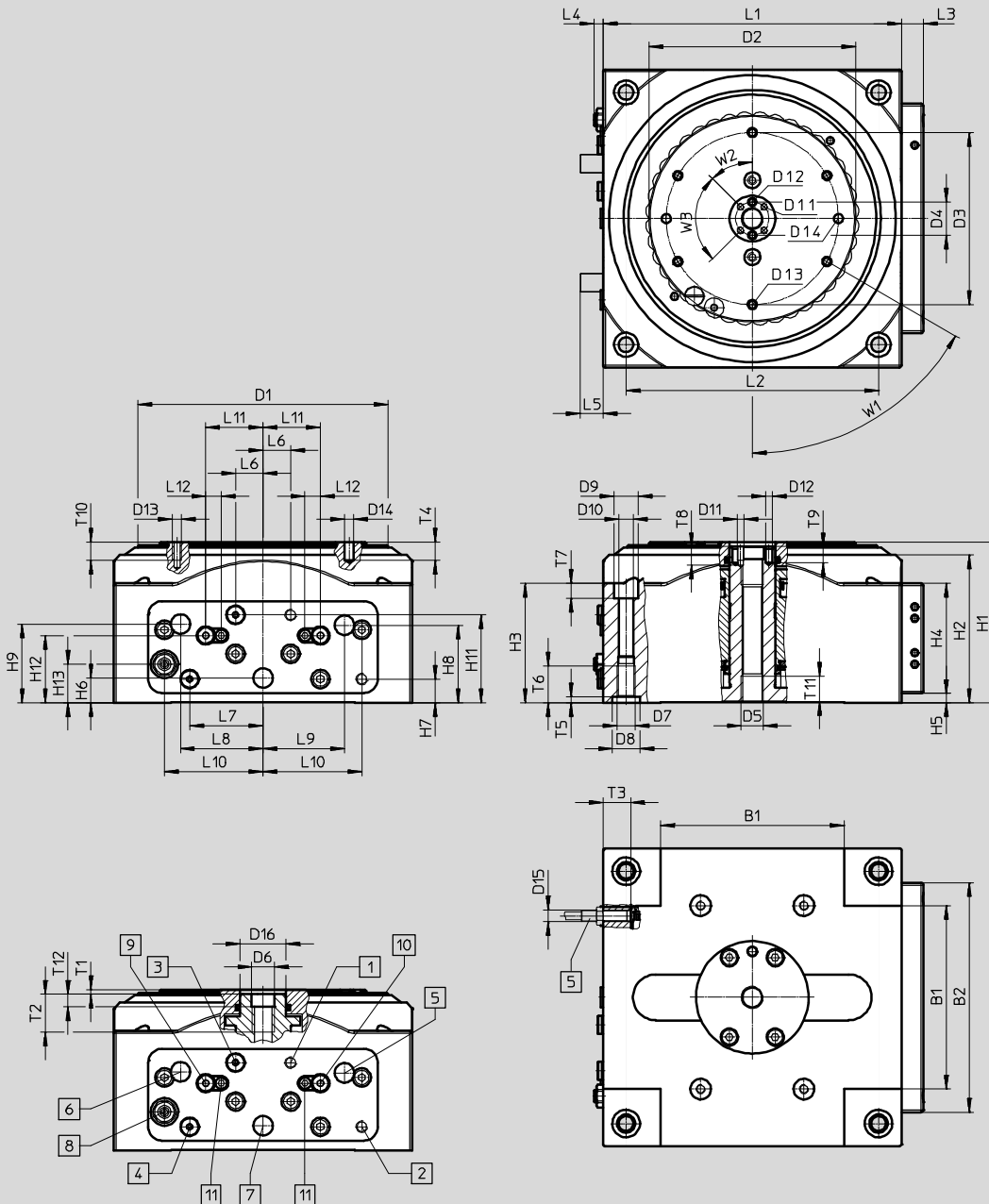

- | | | | |
|---|--|--|--|
| <ul style="list-style-type: none"> 1 Supply port: unlock and rotate (reciprocating motion: unlock) 2 Supply port: lock and return stroke (reciprocating motion: lock) 3 Blanking plug (for reciprocating motion: rotate supply port clockwise) | <ul style="list-style-type: none"> 4 Blanking plug (for reciprocating motion: rotate supply port anticlockwise) 5 Sensor turned for clockwise rotation (sensor initial position for anticlockwise rotation) 6 Sensor initial position for clockwise rotation (sensor turned for anticlockwise rotation) | <ul style="list-style-type: none"> 7 Sensor lock 8 One-way flow control valve 9 Adjustment of end-position cushioning for anticlockwise rotation and reciprocating motion (not applicable for clockwise rotation) | <ul style="list-style-type: none"> 10 Adjustment of end-position cushioning for clockwise rotation and reciprocating motion (not applicable for anticlockwise rotation) 11 Counter-torque for end-position cushioning 2.5 Nm |
|---|--|--|--|

Rotary indexing tables DHTG

Technical data

Size	B1 ³⁾ ±2	B2	D1 ∅	D2 ∅	D3 ¹⁾ ∅	D4 ¹⁾ ∅	D5	D6 ∅ H8	D7	D8 ∅ H8	D9 ∅	D10 ∅
90	80	100	109	90	75	14.5	G1/8	10	M 8	12	10.5	6.4

Size	D11	D12 ∅ H8	D13	D14 ∅ H8	D15	D16 ∅ H8	EE	H1 ±0.5	H2	H3	H4	H5
90	M3	3	M4	4	M5x0.5	20	M5	70	64.4	52	48	4

Size	H6	H7	H8	H9	H11	H12	H13	L1 □ ±0.1	L2 ¹⁾ □	L3	L4	L5 ²⁾ Max.
90	10.75	10.25	33.75	34.25	38.25	29.25	16.75	130	110	9.5	4	10

Size	L6	L7	L8	L9	L10	L11	L12	T1 ±1	T2 Min.	T3	T4 Min.
90	12	32	36	35.5	43	25	6.7	2	16.5	12	8

Size	T5 +0.1	T6 Min.	T7	T8	T9 Min.	T10 Min.	T11 Min.	T12	W1	W2	W3
90	2.6	16	6.5	6	5	8	11	5.5	60°	45°	90°

- 1) Tolerance for centring hole ±0.02 mm.
Tolerance for thread ±0.1 mm.
- 2) Max. projection of shock absorber adjustment
- 3) 0.1 +0.05 recessed

Rotary indexing tables DHTG

Technical data

FESTO

Dimensions

Download CAD data → www.festo.com

Sizes 140, 220

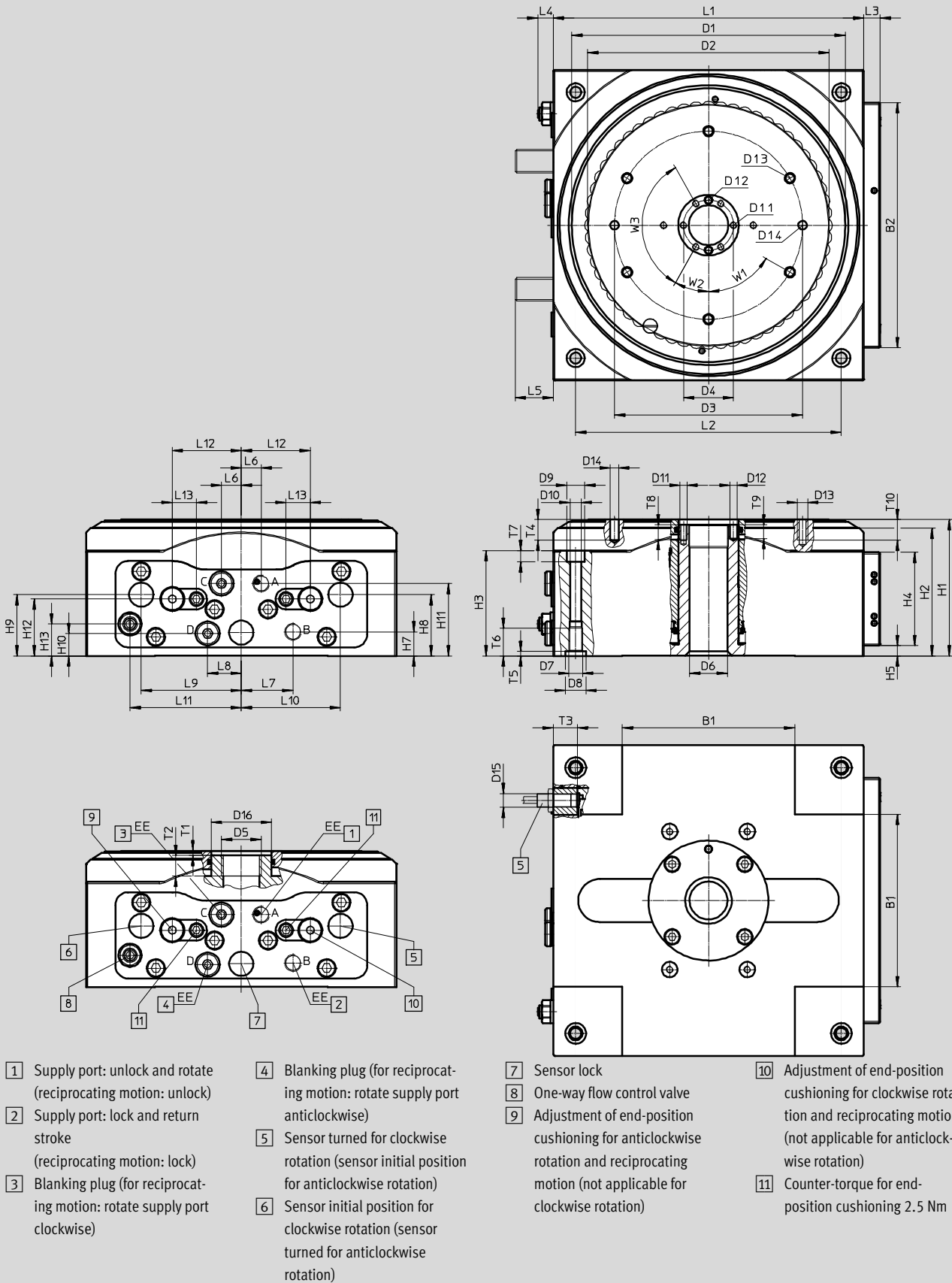

Rotary indexing tables DHTG

Technical data

Size	B1 ³⁾ ±2	B2	D1 ∅	D2 ∅	D3 ¹⁾ ∅	D4 ¹⁾ ∅	D5	D6 ∅	D7	D8 ∅ H8	D9 ∅	D10 ∅	D11	D12 ∅ H8
140	100	142	159	140	109	29	M23x1	22	M 8	12	10.5	6.4	M4	4
220	150	212	239	220	165	67	–	58.4	M10	15	13.5	8.4	M5	5

Size	D13	D14 ∅ H8	D15	D16 ∅ H8	EE	H1 ±0.5	H2	H3	H4	H5	H6	H7	H8	H9
140	M6	5	M8x1	35	G1/8	79	74	61	54	6	13.5	14	35.5	35.5
220	M 8	6	M8x1	75	G1/8	89	83.5	68.5	64	4.5	13.5	24.5	15	15

Size	H10	H11	H12	H13	L1 □ ±0.1	L2 ¹⁾ □	L3	L4 +1	L5 ²⁾ Max.	L6	L7	L8	L9	L10	L11
140	13	42	33	18.5	180	154	9.5	8.9	22	11.5	30	19.5	58	57.5	64.5
220	24.5	50.5	36.5	24	270	228	12	4.6	22	41	41	41	61	61	99.5

Size	L12	L13	T1 ±1	T2 Min.	T3 Min.	T4 Min.	T5 +0.1	T6 Min.	T7	T8 Min.	T9 Min.	T10 Min.	W1	W2	W3
140	40	14	3	12	14	8	2.6	16	6.5	8	8	11	60°	30°	120°
220	68	14	4	–	19	8	3.1	20	8.5	10	10	11	60°	30°	120°

- 1) Tolerance between the centring holes: ±0.02
Tolerance between the threaded holes and countersinks: ±0.2
- 2) Max. projection of shock absorber adjustment
- 3) 0.1 +0.05 recessed

Rotary indexing tables DHTG

Technical data

FESTO

Dimensions – Variants

Download CAD data → www.festo.com

P4 – Pneumatic energy throughfeed

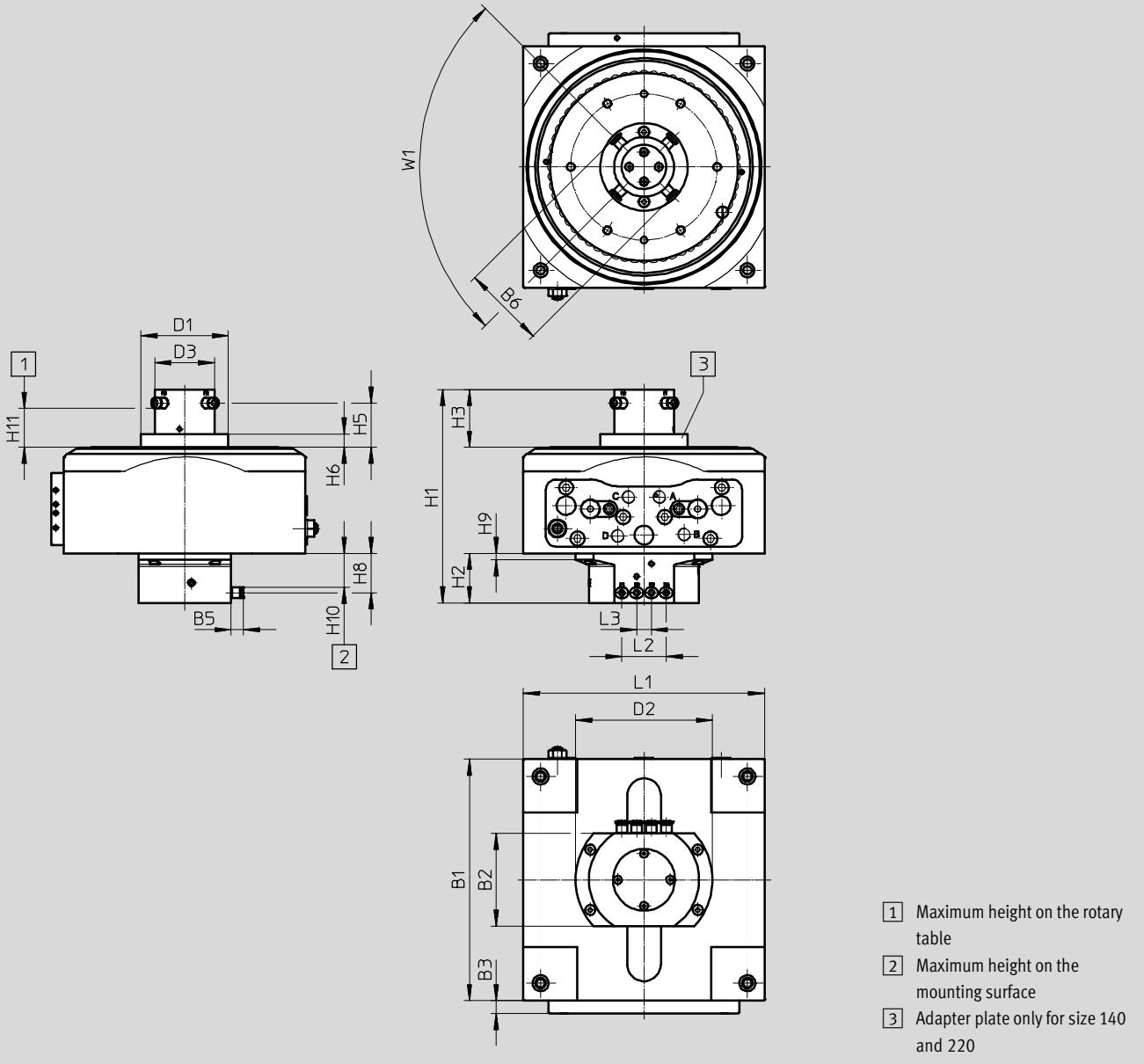

- 1** Maximum height on the rotary table
- 2** Maximum height on the mounting surface
- 3** Adapter plate only for size 140 and 220

Rotary indexing tables DHTG

Technical data

Size	B1	B2 ±0.1	B3	B5	B6	D1 ∅ ±0.1	D2 ∅
65	103	69	9.5	9.3	61.4	-	102
90	130		9.5			-	
140	180		9.5			65	
220	270		12			100	

Size	D3 ∅ ±0.1	H1	H2 ±0.1	H3	H5	H6 ±0.1	H8 ±0.1
65	44.5	125	37	33±0.1	23±0.05	-	29.5
90		140		33±0.1	23±0.05	-	
140		159		43±0.2	33±0.15	10	
220		169		43±0.2	33±0.15	10	

Size	H9	H10	H11	L1	L2 ±0.1	L3 ±0.1	W1
65	5	25	19	95	33	11	90°
90			19	130			
140			29	180			
220			29	270			

Rotary indexing tables DHTG

Technical data

FESTO

Dimensions – Variants

Download CAD data → www.festo.com

P4E4 – Pneumatic/electrical energy throughfeed

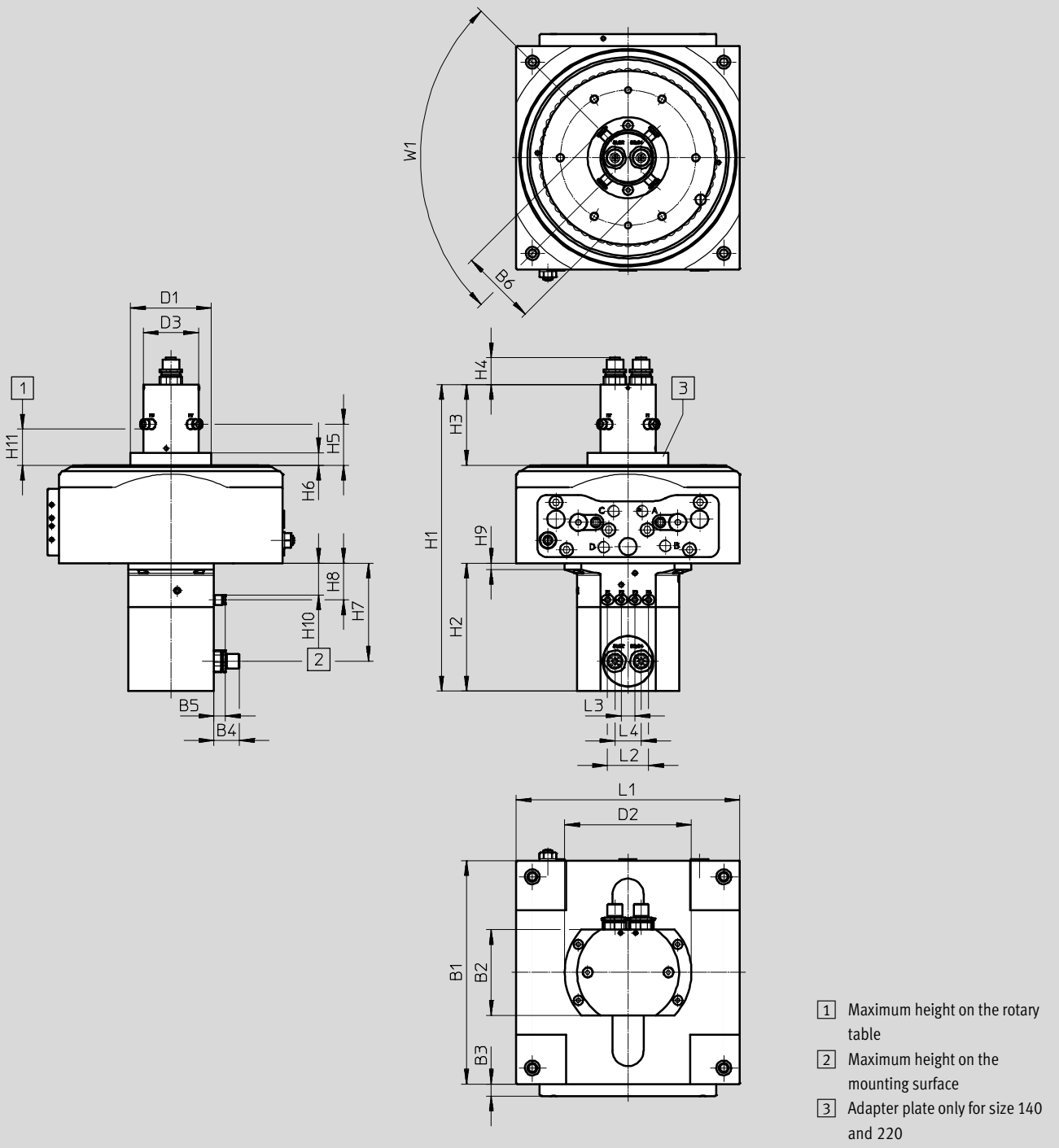

Rotary indexing tables DHTG

Technical data

Size	B1	B2 ±0.1	B3	B4 +3	B5	B6	D1 ∅ ±0.1	D2 ∅	D3 ∅ ±0.1
65	103	69	9.5	19	9.3	61.4	-	102	44.5
90	130		9.5				-		
140	180		9.5				65		
220	270		12				100		

Size	H1	H2 ±0.1	H3	H4 +2	H5	H6 ±0.1	H7	H8 ±0.1
65	213	103	55±0.1	17.5	23±0.05	-	79	29.5
90	228		55±0.1		23±0.05	-		
140	247		65±0.2		33±0.15	10		
220	257		65±0.2		33±0.15	10		

Size	H9	H10	H11	L1	L2 ±0.1	L3 ±0.1	L4	W1
65	5	25	19	95	33	11	21	90°
90			19	130				
140			29	180				
220			29	270				

Rotary indexing tables DHTG

Technical data

FESTO

Dimensions – Variants

Download CAD data → www.festo.com

P4L12 – Pneumatic/electrical energy throughfeed

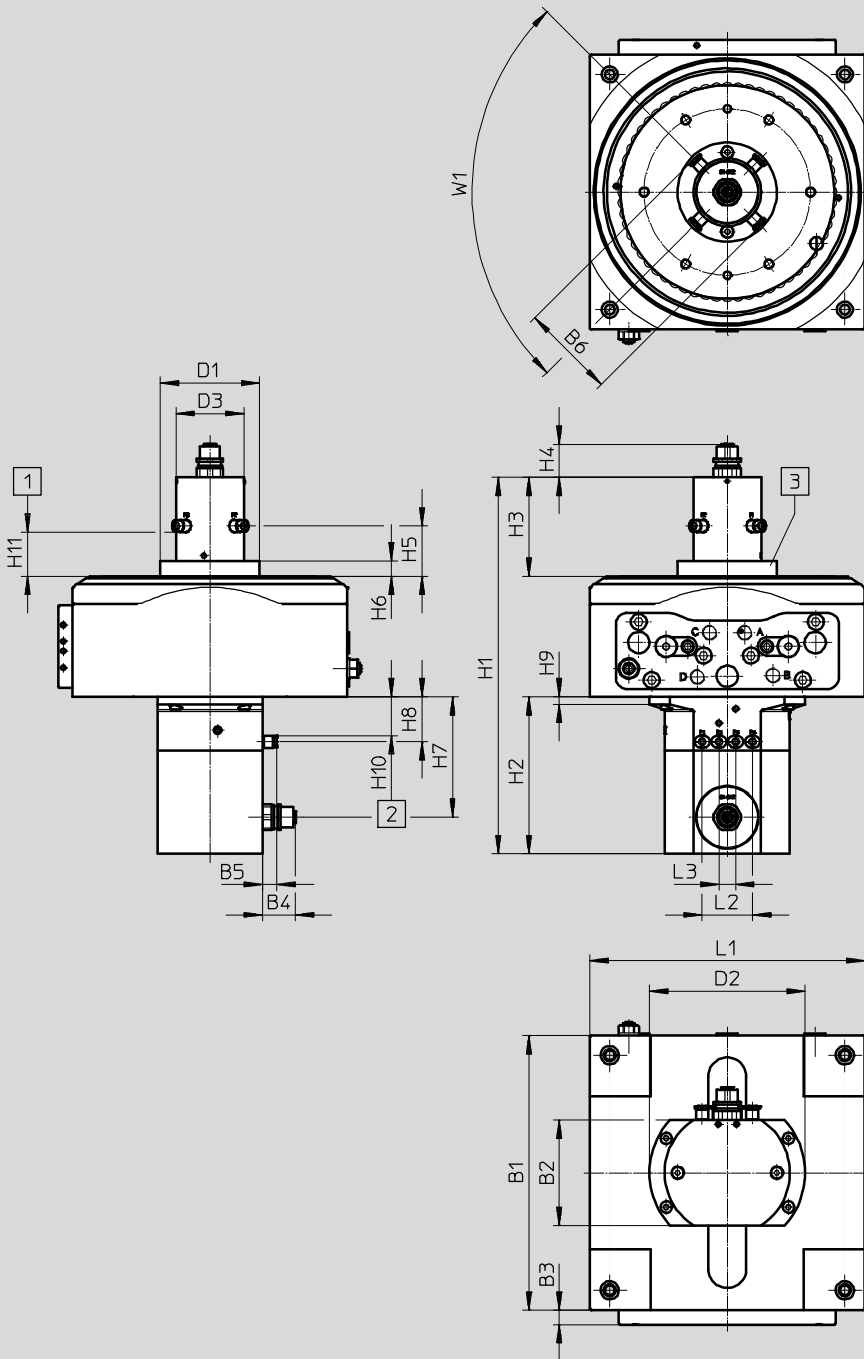

- 1 Maximum height on the rotary table
- 2 Maximum height on the mounting surface
- 3 Adapter plate only for size 140 and 220

Rotary indexing tables DHTG

Technical data

Size	B1	B2 ±0.1	B3	B4 +3	B5	B6	D1 ∅ ±0.1	D2 ∅
65	103	69	9.5	17.5	9.3	61.4	-	102
90	130		9.5				-	
140	180		9.5				65	
220	270		12				100	

Size	D3 ∅ ±0.1	H1	H2 ±0.1	H3	H4 +2	H5	H6 ±0.1	H7
65	44.5	213	103	55±0.1	17.5	23±0.05	-	79
90		228		55±0.1		23±0.05	-	
140		247		65±0.2		33±0.15	10	
220		257		65±0.2		33±0.15	10	

Size	H8 ±0.1	H9	H10	H11	L1	L2 ±0.1	L3 ±0.1	W1
65	29.5	5	25	19	95	33	11	90°
90				19	130			
140				29	180			
220				29	270			

Rotary indexing tables DHTG

Technical data

FESTO

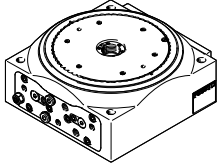
Ordering data				
	Size	Indexing	Part No.	Type
	65	2	548076	DHTG-65-2-A
		3	555448	DHTG-65-3-A
		4	548077	DHTG-65-4-A
		6	548078	DHTG-65-6-A
		8	548079	DHTG-65-8-A
		12	548080	DHTG-65-12-A
		24	548081	DHTG-65-24-A
	90	2	548082	DHTG-90-2-A
		3	555449	DHTG-90-3-A
		4	548083	DHTG-90-4-A
		6	548084	DHTG-90-6-A
		8	548085	DHTG-90-8-A
		12	548086	DHTG-90-12-A
		24	548087	DHTG-90-24-A
	140	3	555450	DHTG-140-3-A
		4	548088	DHTG-140-4-A
		6	548089	DHTG-140-6-A
		8	548090	DHTG-140-8-A
		12	548091	DHTG-140-12-A
		24	548092	DHTG-140-24-A
	220	3	555451	DHTG-220-3-A
		4	548093	DHTG-220-4-A
		6	548094	DHTG-220-6-A
		8	548095	DHTG-220-8-A
12		548096	DHTG-220-12-A	
		24	548097	DHTG-220-24-A

Rotary indexing tables DHTG

Ordering data – Modular product system

Ordering table							
Size	65	90	140	220	Condi- tions	Code	Entry code
M Module no.	575738	575739	575740	575741			
Product type	DHTG G series					DHTG	DHTG
Size	65	90	140	220		-...	
Indexing	2 indexing stations		-			-2	
	3 indexing stations					-3	
	4 indexing stations					-4	
	6 indexing stations					-6	
	8 indexing stations					-8	
	12 indexing stations					-12	
	24 indexing stations					-24	
Position sensing	Via proximity sensor					A	A
O Energy throughfeed	None					-	
	Pneumatic, 4 ducts					-P4	
	Pneumatic, 4 ducts; electric, 4 signals					-P4E4	
	Pneumatic, 4 ducts; electric, 12 cables					-P4L12	

Transfer order code

Rotary indexing tables DHTG

Accessories

FESTO

Adapter kit
DADG-AK

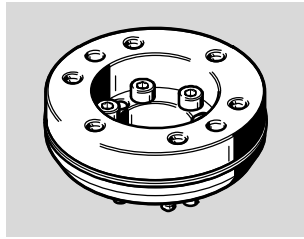

Dimensions

Download CAD data → www.festo.com

With rotary table and adapter kit DADG-AK for mounting a fixed plate

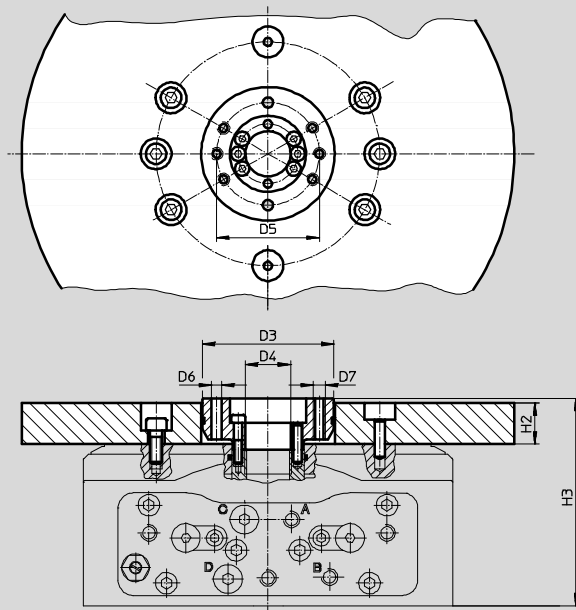

Size	D3 ∅ +0.2	D4 ∅ +0.2	D5 ∅	D6 ∅ H7	D7	H2 Max.	H3 ±0.5
DADG-AK-65	29	5	20	4	M4	15	72
DADG-AK-90	39	9	30	4	M4	15	87
DADG-AK-140	64	22	50	5	M6	20	101
DADG-AK-220	104	58.4	90	6	M8	20	111

Ordering data – Adapter kit DADG-AK

	For size	Part No.	Type
	65	555424	DADG-AK-65
	90	555425	DADG-AK-90
	140	555426	DADG-AK-140
	220	555427	DADG-AK-220

Rotary indexing tables DHTG

Accessories



Rotary distributors

GF-..., single

GF-...-2, multiple



Dimensions

Download CAD data → www.festo.com

With rotary distributor GF-... (single) and adapter kit DADG-AK-...

With rotary distributor GF-1/8-2 (multiple) and adapter kit DADG-AK-220-2G18 – for size 220

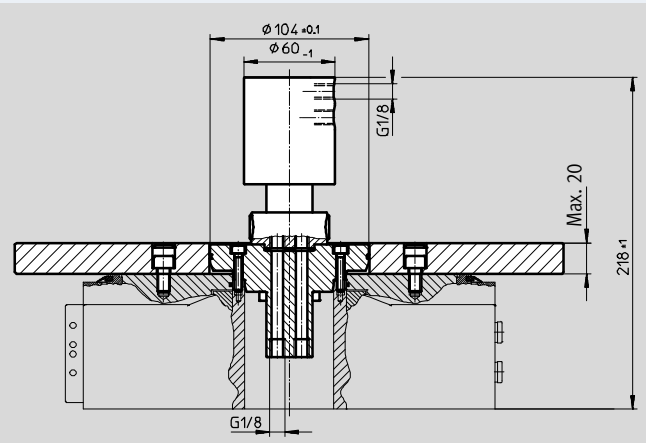
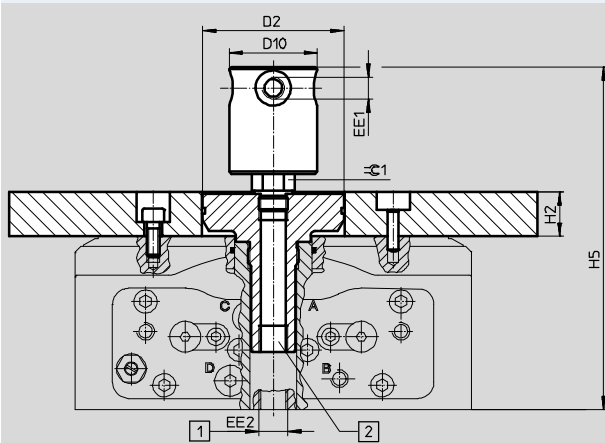

- 1 External supply port for DHTG-65/90
- 2 Internal supply port for DHTG-140/220

Size	D2	D10 Ø +0.2	EE1	EE2	H2 Max.	H5 ±1	⌀ 1
DADG-AK-65-1G18 GF-1/8-M5	29	40	M5	G1/8	15	127.5	17
DADG-AK-90-1G18 GF-1/8-M5	39	40	M5	G1/8	15	142.5	17
DADG-AK-140-1G14 GF-1/4-1/8	64	40	G1/8	G1/4	20	155.5	17
DADG-AK-220-1G12 GF-1/2-1/4	104	60	G1/4	G1/2	20	187.5	27



Ordering data

Rotary distributor GF				Adapter kit DADG-AK			
	For size	Part No.	Type		For size	Part No.	Type
	Simple				Simple		
	65, 90	539290	GF-1/8-M5		65	555428	DADG-AK-65-1G18
	140	539291	GF-1/4-1/8		90	555429	DADG-AK-90-1G18
	220	539292	GF-1/2-1/4		140	555430	DADG-AK-140-1G14
					220	555431	DADG-AK-220-1G12
	Multiple				Multiple		
	220	539287	GF-1/8-2		220	555432	DADG-AK-220-2G18

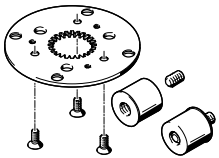

Rotary indexing tables DHTG

Accessories

FESTO

Ordering data					
	For size	Indexing	Part No.	Type	
Indexing conversion kit DADM-CK					
	65	2	548098	DADM-CK-65-2	
		3	554389	DADM-CK-65-3	
		4	548099	DADM-CK-65-4	
		6	548100	DADM-CK-65-6	
		8	548101	DADM-CK-65-8	
		12	548102	DADM-CK-65-12	
		24	548103	DADM-CK-65-24	
	90	2	548104	DADM-CK-90-2	
		3	555445	DADM-CK-90-3	
		4	548105	DADM-CK-90-4	
		6	548106	DADM-CK-90-6	
		8	548107	DADM-CK-90-8	
		12	548108	DADM-CK-90-12	
		24	548109	DADM-CK-90-24	
	140	3	555446	DADM-CK-140-3	
		4	548110	DADM-CK-140-4	
		6	548111	DADM-CK-140-6	
		8	548112	DADM-CK-140-8	
		12	548113	DADM-CK-140-12	
		24	548114	DADM-CK-140-24	
		220	3	555447	DADM-CK-220-3
	4		548115	DADM-CK-220-4	
	6		548116	DADM-CK-220-6	
	8		548117	DADM-CK-220-8	
12	548118		DADM-CK-220-12		
24	548119		DADM-CK-220-24		
Reciprocating motion kit DADM-TK					
	65	-	548120	DADM-TK-65	
	90		548121	DADM-TK-90	
	140		563304	DADM-TK-140	
	220		563305	DADM-TK-220	

Ordering data – Proximity sensor, inductive					Technical data → Internet: sien	
	For size	Contact	Connection	Part No.	Type	
	65, 90	N/O contact	Plug	150371	SIEN-M5B-PS-S-L	
		N/C contact	Plug	150375	SIEN-M5B-PO-S-L	
	140, 220	N/O contact	Cable	150386	SIEN-M8B-PS-K-L	
			Plug	150387	SIEN-M8B-PS-S-L	
		N/C contact	Cable	150390	SIEN-M8B-PO-K-L	
			Plug	150391	SIEN-M8B-PO-S-L	

Ordering data – Connecting cables					Technical data → Internet: nebu	
	Electrical connection, left	Electrical connection, right	Cable length [m]	Part No.	Type	
	Straight socket, M8x1, 3-pin	Cable, open end, 3-wire	2.5	541333	NEBU-M8G3-K-2.5-LE3	
			5	541334	NEBU-M8G3-K-5-LE3	
	Angled socket, M8x1, 3-pin	Cable, open end, 3-wire	2.5	541338	NEBU-M8W3-K-2.5-LE3	
			5	541341	NEBU-M8W3-K-5-LE3	

Rotary indexing tables DHTG

Accessories



Wiring of the proximity sensor in combination with the energy throughfeed

Sample illustration using DHTG-...-P4E4

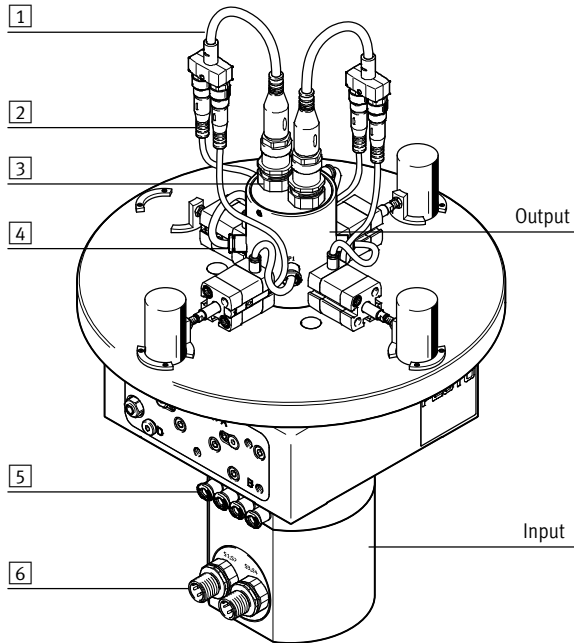

- 1 Y-distributor
NEDY-L2R1-V1-...
- 2 Proximity sensor with plug
- 3 Electrical connection (output)
- 4 Supply port (output)
- 5 Supply port (input)
- 6 Electrical connection (input)

Note

For variant DHTG-...-P4E4, proximity sensors with plugs must be used for the attachments at the output. These are then connected to the energy throughfeed module using a Y-distributor.

Ordering data – Connecting cables for proximity sensor

	Electrical connection, left	Electrical connection, right	Suitable for use with energy chains	Cable length [m]	Part No.	Type
DHTG-...-P4E4						
Input						
	Straight socket, M12x1, 5-pin	Cable, open end, 4-wire	■	2.5	550326	NEBU-M12G5-K-2.5-LE4
				5	541328	NEBU-M12G5-K-5-LE4
Output						
	Straight plug, M12x1, 4-pin	2x straight sockets, M8x1, 3-pin	-	0.3 ¹⁾	8032867	NEDY-L2R1-V1-M8G3-U-M12G4-0.3R
DHTG-...-P4L12						
Input/output						
	Straight plug, M12x1, 12-pin	Straight plug, M12x1, 12-wire	■	0.3	3947404	NEBS-SM12G12-E-0.3-N-M12G12
		Cable, open end, 12-wire	■	0.5	3947401	NEBS-SM12G12-E-0.5-N-LE12
				5	3947395	NEBS-SM12G12-E-5-N-LE12

1) Cable lengths can be selected between 0.3 m and 30 m → Internet: nedy

Ordering data – Rotary throughfeed

	Description	Part No.	Type
	Spare part for energy throughfeed. Can be replaced as needed.	3920687	DHAS-SCR12-H6

Festo - Your Partner in Automation



1 Festo Inc.
5300 Explorer Drive
Mississauga, ON L4W 5G4
Canada

Festo Customer Interaction Center
Tel: 1 877 463 3786
Fax: 1 877 393 3786
Email: customer.service.ca@festo.com



2 Festo Pneumatic
Av. Ceylán 3,
Col. Tequesquináhuac
54020 Tlalnepantla,
Estado de México

Multinational Contact Center
01 800 337 8669
ventas.mexico@festo.com



3 Festo Corporation
1377 Motor Parkway
Suite 310
Islandia, NY 11749

Festo Customer Interaction Center
1 800 993 3786
1 800 963 3786
customer.service.us@festo.com



4 Regional Service Center
7777 Columbia Road
Mason, OH 45040

Connect with us



www.festo.com/socialmedia



www.festo.com

Subject to change